

2024

# EMERGENCY MANAGEMENT SERVICES

## Yearbook and Buyer's Guide

**Volume 31**



# Dräger

## Technology for Life

### Dräger PSS® Airboss

The Dräger PSS® AirBoss offers best in class ergonomics and is one of the lightest weight breathing apparatus for firefighting. Lessons learned from firefighters around the world as well as latest innovations in technology have led us to design an even safer and cleaner SCBA system that enables you to breathe more easily and for longer.

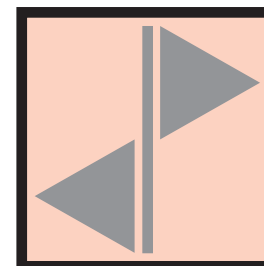

(Date of publication)

**February 2024**

#### Emergency Services Yearbook and Buyer's Guide

is published by:

#### Delinds Publications cc

(reg no CK1990/013388/23)

12 Delta Road  
Blairgowrie  
Randburg

PO Box 72366  
Parkview  
2122

Tel: +27 (0)11 886-5985  
Cell no: +27 (0) 83 266 6662  
E-mail: [delinds@mweb.co.za](mailto:delinds@mweb.co.za)  
<https://www.emsguide.co.za>

#### PUBLISHER:

Debbie Myer (BA) SA

#### EDITOR:

Lindsay Myer

The publishers are not responsible for any loss or damage to advertising or any material entrusted to them, and reserve the right to edit all contributions. Whilst every effort is made to ensure accuracy in this publication, the publishers, editors and printers do not accept any responsibility for errors or omissions in the content. The publishers and editors are not liable for damages incurred whatsoever by any person, company or entity as a result of action upon any statement contained in this publication.

The opinions expressed do not reflect the policy of the publishers or editors.

The publishers and editors do not endorse nor guarantee any products or claims made by the manufacturers and advertisers.

© 2024. No part of this publication may be reproduced or transmitted in any form or by any means electronic or mechanical including photocopying, recording or by any information storage or retrieval system, without the permission in writing from the publisher.

## Emergency Services Yearbook and Buyer's Guide - Volume 31

### CONTENTS

|  |        |
|--|--------|
| Business cards   | 4-5    |
| Products and Services  | 6-99   |
| Alarm, alerting, dispatch<br><i>(includes fleet management solutions)</i>  | 6      |
| Breathing air/compressors  | 9      |
| Chemical/hazard protection   | 14     |
| Body protection<br><i>(includes helmets, eyewear, gloves, footwear, bunker gear, structural fire fighting suits, balaclava, jumpsuits, tactical wear, hoods)</i> | 19     |
| Gas detectors  | 26     |
| Health risk assessment   | 27     |
| Fire fighting equipment<br><i>(includes pumps, nozzles, monitors, foam equipment, hoses, PPV, adaptors, lighting, thermal, water mist, cabs)</i>                 | 27     |
| Respiratory protection   | 54     |
| Rescue equipment<br><i>(includes hydraulic equipment, ropes, shoring, battery operated rescue systems, USAR, water rescue, confined space)</i>                   | 40     |
| Risk assessment  | 55     |
| Training   | 58     |
| Thermal imaging  | 30, 56 |
| Vehicles<br><i>(includes heavy hazmat, pumpers - heavy, attack, RIVs, water supply systems, trailers, rescue, wildland, aerial platforms, recycle)</i>           | 63     |
| Advertiser's profiles  | 92     |
| Product cross index  | 100    |
| SAESI  | 106    |
| Fire Departments   | 118    |

# EMS CONFERENCE 2024

QUO VADIS: FUTURE OF FIRE SAFETY AND THE EMERGENCY SERVICES - INNOVATIONS AND SOLUTIONS

MODERNISATION OF THE FIRE SERVICES

FIRE FIGHTER OCCUPATIONAL DISEASES

RISK ASSESSMENTS SAVE LIVES

A ROUTINE FIRE IS A MYTH

DISASTER MANAGEMENT : CHANGING WEATHER PATTERNS

TRAINING: CHANGES TO REQUIREMENTS

STRONG TEAM BUILDING THROUGH EMPLOYEE WELLNESS

FIRST RESPONDER MENTAL HEALTH

TENDERS: ENSURE DELIVERABLES MEET EXPECTATIONS/

STANDARDS AND APPROVALS

ELECTRIC VEHICLE AND LITHIUM FIRES

PRODUCT INNOVATIONS

HAZMAT TRANSPORTATION AND STORAGE

LEGAL PITFALLS

**23-24 July 2024**

Fire fighter challenge - 25 July 2024

**Venue:**

Dräger Auditorium  
Sandton

**Tel:**

+27 83 266 6662

**Email:**

debbie@safety1st.co.za

**Websites:**

www.safety1st.co.za

www.emsguide.co.za

# EMS CONFERENCE 2024

QUO VADIS: FUTURE OF FIRE SAFETY AND THE EMERGENCY SERVICES - INNOVATIONS AND SOLUTIONS

- This conference is of interest to anyone involved in **municipal, industrial and private fire and emergency services.**
- This much-needed event will provide a forum for knowledge and experience to be shared in our modernising and changing world.
  - Delegates will leave with a wider knowledge, understanding and improved capabilities.
  - The conference will also offer an opportunity for product demonstrations and networking.

## SPONSORSHIP PACKAGES

|   | Gold           | Silver         | Bronze         |
|---|----------------|----------------|----------------|
| <b>Cost</b>   | <b>R50,000</b> | <b>R35,000</b> | <b>R20,000</b> |
| Company profile on SFA and EMS Guide websites             | ✓              | ✓              |                |
| Front cover ad & feature article in African OS&H magazine | ✓              |                |                |
| Website logo & link on SFA and EMS Guide websites         | ✓              | ✓              | ✓              |
| Website banner advert on SFA and EMS Guide websites       | ✓              | ✓              | ✓              |
| Advert in EMS Buyer's Guide (distributed at conference)   | ✓(FP)          | ✓(FP)          | ✓(HP)          |
| Logos on all marketing material                           | ✓              | ✓              | ✓              |
| Pop-up banner in auditorium                               | ✓              |                |                |
| Pop-up banner in exhibitor area                           | ✓              | ✓              | ✓              |
| Inserts in delegate bags                                  | ✓              | ✓              |                |
| Delegate registration                                     | 6              | 4              | 2              |

|                            |  |
|----------------------------|--|
| Pop-up banner (x 1)        | R2,000   |
| Inserts into delegate bags | R3,000 (non exhibitors)<br>R1,000 (exhibitors)                             |
| Delegate bags              | R15,000 (Includes bags selected by organiser - sponsor logo in one colour) |
| Speaker gifts              | R3,000 (excludes gifts)  |
| Lanyards                   | R3,000 (lanyards supplied by sponsor)                                      |

## Exhibition stands - R10,000

- Includes:
- 2 x delegate registrations
  - 3 days - 2 x conference days plus 1 x fire challenge day
  - Table and 2 x chairs (Or, there will be space for gazebos)

All prices quoted on this page are exclusive of vat

## Delegate registration fees per person

**Early bird** R5,000.00  
(Booking before 28 March 2024)

**From 16 March** R6,000.00  
(Fees are excl VAT)

Delegate fees include 2 days attendance at the conference, delegate bag, teas, lunches and cocktails on 23rd July 2024.

Excludes accommodation and travel

To register go to [www.safety1st.co.za/events/](http://www.safety1st.co.za/events/)

Organiser



Safety First Association

Supporting Organisation



SAESI

Official Publications



Delinds Publications cc  
EMS GUIDE

Organisers



SAFETY FIRST ASSOCIATION

Supporting Organisation



SAESI

Venue Partner



Official Publications



EMS GUIDE

Contact Debbie Tel: +27 (0)11 8865985 Cell: + (0)83 266 6662 Email: debbie@safety1st.co.za

Alcohol and Drug testing **specialists**



**ALCO-Safe**  
(Pty) Ltd

Phone: + 27 12 343 8114 or visit [www.alcosafe.co.za](http://www.alcosafe.co.za)

**Divetek**   
**Compressors**

[www.compressors.divetek.co.za](http://www.compressors.divetek.co.za)

SALES AND SERVICING OF HIGH PRESSURE SYSTEMS



Address: Unit 15, Skyview Retail Park, Cnr CR Swart & Freda Road, Bromhof, JHB, South Africa  
Contact: +27 11 791 1095  
[compressors@divetek.co.za](mailto:compressors@divetek.co.za)



<https://www.aquilacorpsa.co.za>  
<https://www.trtg.co.za>  
Mobile: +27 (0) 82 609 3438

**AQUILACORP**

Unit 18, Aquaplan Business Park  
120 E.P. Malan Street  
Pomona, Kempton Park  
South Africa



Tel +27 (0) 11 059 4200  
Visit [www.draeger.co.za](http://www.draeger.co.za)

Dräger. Technology for Life®



**BRONTO SKYLIFT**  
Safety above all

Email: [info@industrialfire.co.za](mailto:info@industrialfire.co.za)  
Website: <https://www.industrialfire.co.za>



**EMS CONFERENCE 2024**  
QUO VADIS: FUTURE OF FIRE SAFETY AND THE EMERGENCY SERVICES - INNOVATIONS AND SOLUTIONS

23-24 July 2024  
Email: [debbie@safety1st.co.za](mailto:debbie@safety1st.co.za)  
Cell: 083 266 6662  
<https://www.safety1st.co.za/events/>



HIGH PRESSURE COMPRESSORS FOR PURE BREATHING AIR

**COLTRI COMPRESSORS**

[steve@coltri.co.za](mailto:steve@coltri.co.za)  
+27 82 449 3576  
[www.coltri.co.za](http://www.coltri.co.za) | [www.coltri.com](http://www.coltri.com)

Specialising in Fire, Fire Servicing and Safety as well as Drug and Alcohol Testers



Tel: +27 11 908 6960  
Email: [enquiries@firebreaksa.co.za](mailto:enquiries@firebreaksa.co.za)  
[sales@firebreaksa.co.za](mailto:sales@firebreaksa.co.za)  
<https://www.firebreaksa.co.za>

**FIREBREAK SA**  
SAFETY APPLIANCES PTY LTD

**Delinds Publications cc**

Publishers of the Emergency Services Yearbook & Buyer's Guide



Tel: +27 (0)11 886 5985  
Cell: 083 266 6662  
Email: [delinds@mweb.co.za](mailto:delinds@mweb.co.za)  
[www.emsguide.co.za](http://www.emsguide.co.za)

**Granite Designs**

**EMBROIDERY REQUIREMENTS**

Contact June  
Cell: 066 312 6505  
Email: [junestjohn06@yahoo.com](mailto:junestjohn06@yahoo.com)



**AQUILACORP**  
[www.aquilacorpsa.co.za](http://www.aquilacorpsa.co.za)  
[www.trtg.co.za](http://www.trtg.co.za)

**holmatro**  
mastering power

Unit 18, Aquaplan Business Park, 120 E.P. Malan Street, Pomona, Kempton Park, South Africa



**RURAL METRO**  
EMERGENCY MANAGEMENT SERVICES (PTY) LTD

Tel: + 27 (0) 33 345 0080  
[headoffice@ruralmetro.com](mailto:headoffice@ruralmetro.com)  
<https://www.ruralmetro.co.za>



**INDUSTRIAL FIRE**  
& HAZARD CONTROL

Email: [info@industrialfire.co.za](mailto:info@industrialfire.co.za)  
Website: <https://www.industrialfire.co.za>



The oldest occupational health and safety association in South Africa

**Celebrating over 80 years of safety**

Posters  
Induction booklets  
Journal  
Informative books



Safety Audits  
Conferences  
Training

Tel: +27 (0) 83 266 6662 E-mail: [debbie@safety1st.co.za](mailto:debbie@safety1st.co.za)  
<https://www.safety1st.co.za>



**LYMAE**  
quality protection equipment

P.O. Box 39966  
Moreleta Park  
Pretoria 0044  
Tel: +27(12) 345-5885  
email: [sales@lymae.co.za](mailto:sales@lymae.co.za)  
[lymae@mweb.co.za](mailto:lymae@mweb.co.za)  
[www.lymae.co.za](http://www.lymae.co.za)

Johan Nel  
Cell 082 322 6002  
Nicolene Van Der Walt  
Cell 082 733 6674



Tel: +27 (11) 300 3300  
0861.SYSMAN (797626)  
F: +27 (11) 219 7430 e-fax  
+27 (11) 300 3315  
W: [www.sysman.co.za](http://www.sysman.co.za)

Sysman Park, 69 Bultfontein Rd,  
Lanseria, Gauteng, South Africa  
PO Box 539, Lanseria, 1748  
25°57'51.94" S / 27°56'53.06" E



**Marcé**  
Excellence Through Innovation

Address  
1012 Ergon Street  
Lytelton, Centurion  
Gauteng, South Africa

Web  
[sales@marce.co.za](mailto:sales@marce.co.za)  
<https://www.marce.co.za>  
+27 12 742 9200

<https://www.aquilacorpsa.co.za> Mobile: +27 (0) 82 609 3438  
<https://www.trtg.co.za>



Suppliers of Holmatro Rescue Equipment - world-class hydraulic rescue equipment  
Excellent after sales service



**RESCUE SOUTH AFRICA**

NGO  
NPO

| RESCUE TRAINING |  
| DISASTER RESPONSE |

Should you wish to complete any of our Rescue Courses, up-skill your emergency medical service and/or develop a Rescue Proto Team...  
+2782 459 9765  
Email: [ian@rescue-sa.co.za](mailto:ian@rescue-sa.co.za)  
Please contact us: [www.rescue-sa.co.za](http://www.rescue-sa.co.za)



**VANGUARD**  
FIRE & SAFETY

SERIOUS ABOUT SAFETY  
A member of the Industrial Safety Services Group

EXCLUSIVE DISTRIBUTORS OF



+27 (0)31 564 3200 | [info@vanguardafrica.co.za](mailto:info@vanguardafrica.co.za) | [www.vanguardfire.co.za](http://www.vanguardfire.co.za)



## Metropolitan/Municipal Fleet Management Solutions

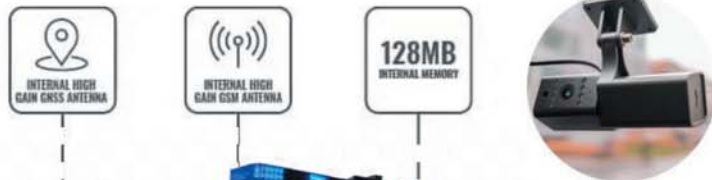

DualCam Systems

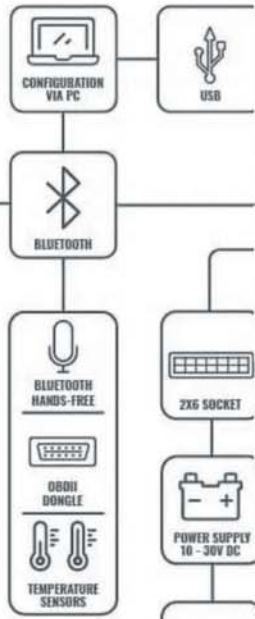
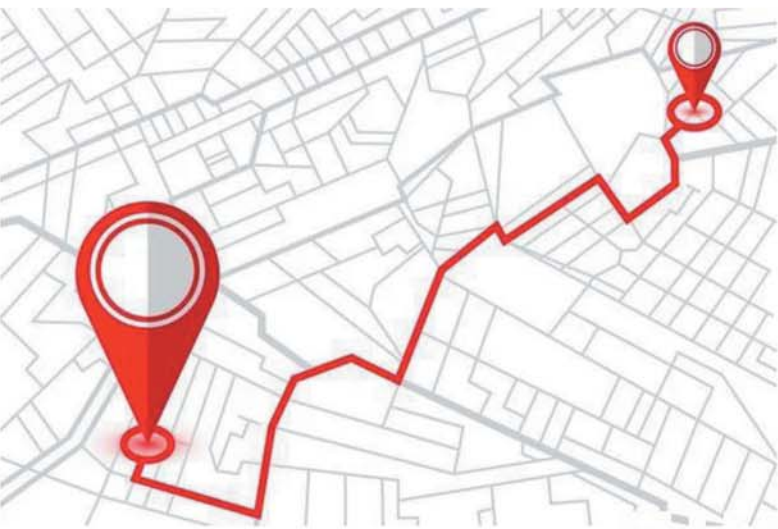
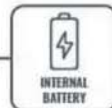

Advanced Driver Assistance Systems (ADAS)

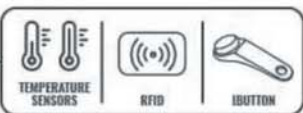
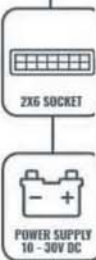

Mobile Data Terminal



Computer Interface

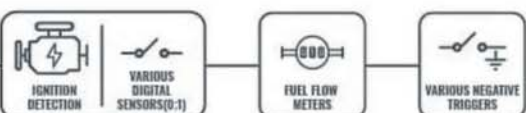

Wireless Driver and Crew ID

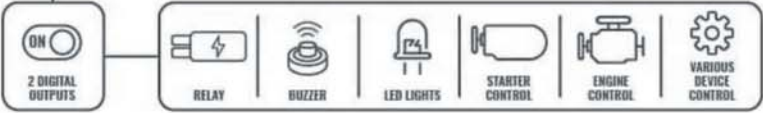

Asset Tags



Full Lifecycle Fleet Management  
 Asset Management  
 Maintenance Management  
 Fuel Management

Contact Sysman  
 +27 (11) 300 3300  
 sales@sysman.co.za  
 www.Sysman.co.za



# EMERGENCY SERVICES SYSTEM

- Call Taking, Dispatch & Resources Management Systems
- Integrated Radio Dispatch Consols / Mapping / GIS Capabilities
- Automated Station Control, Paging / Messaging
- Automated and Customisable Checklists & Procedures
- Real-time Wallboard Displays



Tel 0861 SYSMAN  
 email: info@sysman.co.za  
 website: www.sysman.co.za

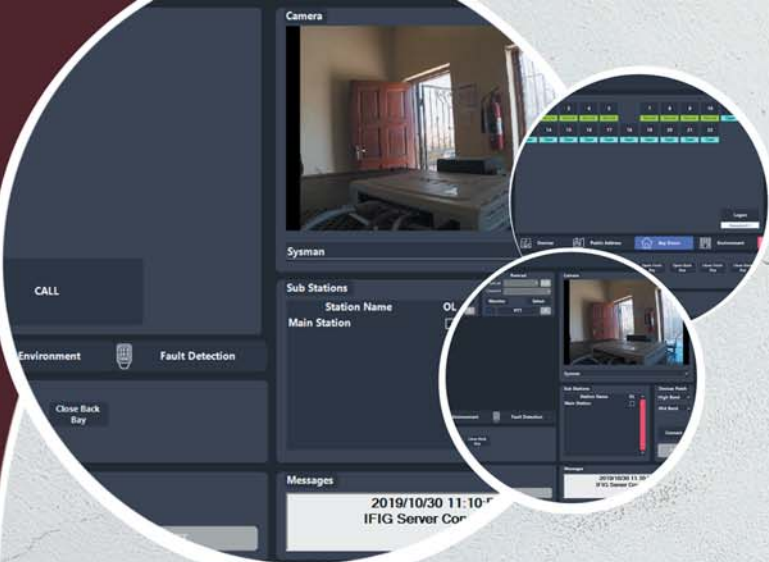

## iFIG MULTI SYSTEM CONTROL SOLUTION

- Radio over IP - Access your Radios from anywhere on your WAN
- Intercom & PA- Full PA System with Individual Point Calling / Call Back Capabilities
- Station Controls - Soft Control Bells, Bay Doors, Gates, Booms, Robots, Doors, Lights, Sirens and other 3rd Party Integration
- Ease of Setup - Quick Configuration of Paramaterised Software

 Tel 0861 SYSMAN  
email: info@sysman.co.za  
website: www.sysman.co.za



## ESS-DIMS DISASTER MANAGEMENT CONTROL CENTRE SOLUTIONS

- Unified Command System
- Improves Role Player Co-ordination, Response & Information Sharing
- Enables Response Agencies to plan Events / Incidents / Disasters
- Enables a Quick Response to Unplanned Crises
- Integrated Document Management and Mass Communications

 Tel 0861 SYSMAN  
email: info@sysman.co.za  
website: www.sysman.co.za



## EMERGENCY SERVICES SYSTEM

- Call Taking, Dispatch & Resources-Management Systems
- Integrated Remote Despatch Consols / Mapping / GIS Capabilities
- Automated Station Control, Paging / Messaging
- Automated and Customisable Checklist & Procedures
- Real-Time Wallboard Displays

 Tel 0861 SYSMAN  
email: info@sysman.co.za  
website: www.sysman.co.za



## SCM SERVICE CALL MANAGEMENT

- Despatch Service Personnel carrying Mobile Tablet Devices
- Schedule Service Calls using Least Cost Routing
- Navigate Service Personnel to Service Locations
- Monitor Location and Service Personnel Performance
- Immediate Updates on Completed Calls

 Tel 0861 SYSMAN  
email: info@sysman.co.za  
website: www.sysman.co.za

**COLTRI 60** YEARS OF COMPRESSOR HISTORY



## High Pressure Compressors for pure breathing air + Nitrogen, Hydrogen, Helium & CNG



Distributed by COLTRI SOUTH AFRICA  
steve@coltri.co.za +27 82 449 3576 [www.coltri.com](http://www.coltri.com) [www.coltri.co.za](http://www.coltri.co.za)



# INFINITE SOLUTIONS FOR HIGH PRESSURE APPLICATIONS

- Sales of Breathing air Compressors
- Sales, Service & Maintenance
- Installations
- Cascade Systems
- Surface Supply Units
- Cylinder Safety

# Divetek Compressors

SALES AND SERVICING OF HIGH PRESSURE SYSTEMS



FIRE FIGHTING

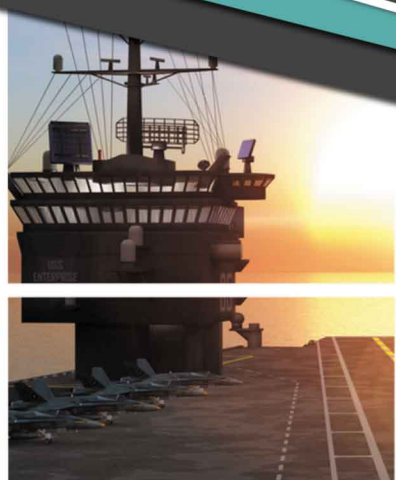

MILITARY



SCUBA DIVING



PAINTBALL

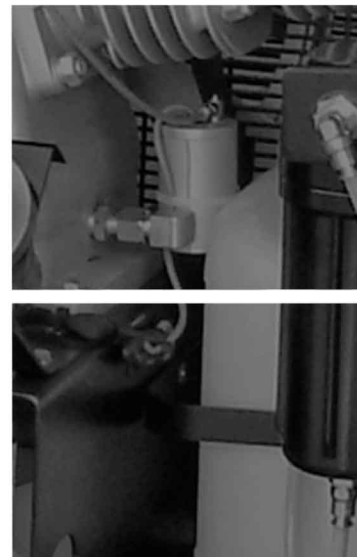
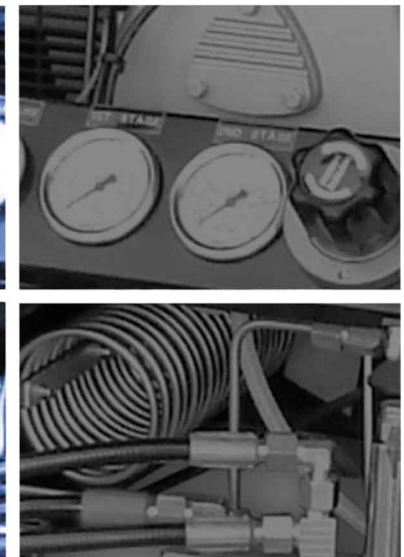
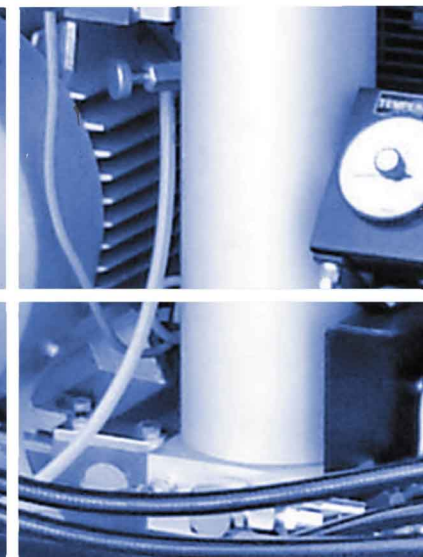
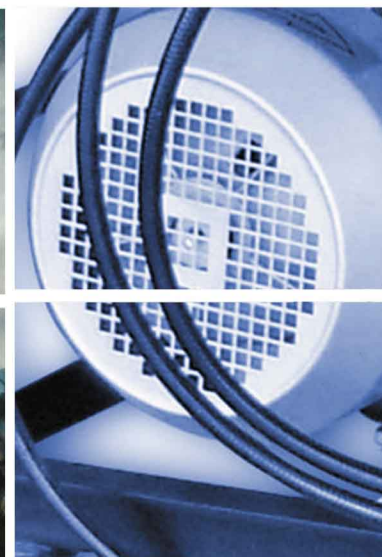
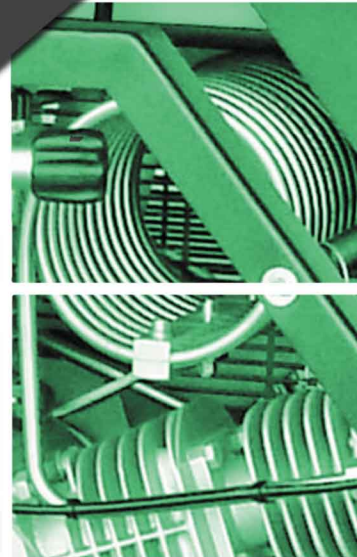
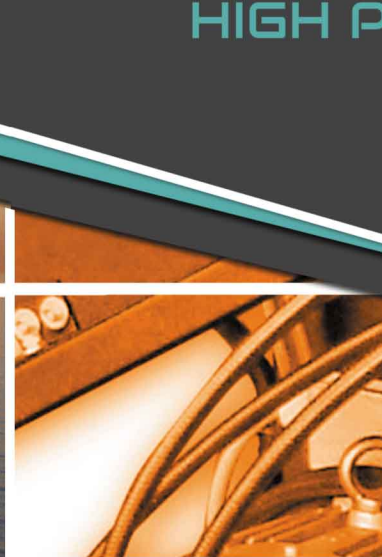

## ABOUT US

Divetek Compressors not only supplies High Pressure Equipment to local Sub-Saharan African Industries from overseas but, over the years have designed, developed and manufactured numerous custom built installations and turnkey systems to suit the specific needs of the client. Our technicians have approximately 35 years experience within the industry, from sales, to installations as well as service and maintenance of all high pressure applications.

## ADDRESS

Unit 15, Skyview Retail Park, CNR of CR Swart and Freda Road, Bromhof, JHB, South Africa

## TEL

011 791 1095

## EMAIL

compressors@divetek.co.za

Proud Agents for

# PARAMINA

[compressors.divetek.co.za](http://compressors.divetek.co.za)

# Dräger Technology for Life



## Dräger PAS® Airpack 2

Designed using leading technology and materials, Dräger's range of heavy-duty airline apparatus is ideal for use where an extended duration of breathing air is called for. Chemical tank cleaning, toxic spillages or certain tasks when working on offshore installations are all made easier and more comfortable when using the Dräger PAS® AirPack 2



# RURAL METRO

EMERGENCY MANAGEMENT SERVICES (PTY) LTD

Rural Metro Emergency Management Services (PTY) LTD cares about the safety of our communities. Pursuing prevention is our key strategy.

We are a fully independent organization specializing in Fire Brigade Services, Training and Disaster Management.

With 23 years of fire service solutions, we put your safety first:-

- Professional Firefighters
- World-Class Fire Protection
- Community Firefighting Services
- Industrial Firefighting Services
- Fire Safety Consultancy

### OUR SERVICES



Fire Rescue Response



HAZMAT Services



Accredited Training



Disaster Management



Emergency Communications



Special Projects

### OUR CLIENTS INCLUDE BOTH THE PRIVATE AND PUBLIC SECTOR WITHIN THE FOLLOWING INDUSTRIES:-



Aviation



Rail



Marine



Automotive



Energy



Mining



Manufacturing



Petrochemical

### OUR VALUE PROPOSITIONS



Dedicated to Saving Lives



Building Professional Firefighting Capacity



Innovative



Turnkey Risk Management



Adaptable and Scalable Solutions



[www.ruralmetro.co.za](http://www.ruralmetro.co.za)







# FIREBREAK SA

SAFETY APPLIANCES PTY LTD

'SINCE 1996'

## EVERYTHING YOU NEED TO SUIT UP



### Level A Gas Tight total encapsulating chemical protective suit

For the highest level of protection

Chemical protective clothing, Category III

#### Overview of Tychem® TK advantages

- Gas-tight, very good chemical barrier qualities
- Lightweight, soft and flexible
- Good material durability and tear resistance
- Highly visible lemon yellow colour
- Permanent physical properties that work in a wide variety of temperatures
- Permeation data available for many chemicals
- Available with integrated chemical protection boots or boot socks with splash protection
- Sizes S - XXL



OUR CONTACT DETAILS

**FIREBREAK SA**  
 14 COMBRINCK STREET, ALRODE, ALBERTON 1451  
 TEL NO: +27 11 908 6960  
 EMAIL: [ENQUIRIES@FIREBREAKSA.CO.ZA](mailto:ENQUIRIES@FIREBREAKSA.CO.ZA)  
 WEB SITE: [WWW.FIREBREAKSA.CO.ZA](http://WWW.FIREBREAKSA.CO.ZA)



# FIREBREAK SA

SAFETY APPLIANCES PTY LTD

'SINCE 1996'

## EVERYTHING YOU NEED TO SUIT UP

Taking on the toughest jobs requires an even tougher person, some jobs are reserved for the brave, the fearless, and the heroic. And to those dedicated to pushing the limits, DuPont™ is dedicated to keeping you protected - every step of the way.

THE PROTECTION EVERY HERO DESERVES



DuPont™ Tyvek® 2000 C sleeve



DuPont™ Tyvek® 500 Boot cover with antislip model POBA. Slip-retardant sole. Stitched internal seams. Elastic top. Fixation ties. White.



DuPont™ Tyvek® 500 Labcoat with zipper model PL309NP. Stitched internal seams. Collar. Zipper. Without pockets. Elasticated cuffs (tunnelled). White.

OUR CONTACT DETAILS

**FIREBREAK SA**  
 14 COMBRINCK STREET, ALRODE, ALBERTON 1451  
 TEL NO: +27 11 908 6960  
 EMAIL: [ENQUIRIES@FIREBREAKSA.CO.ZA](mailto:ENQUIRIES@FIREBREAKSA.CO.ZA)  
 WEB SITE: [WWW.FIREBREAKSA.CO.ZA](http://WWW.FIREBREAKSA.CO.ZA)





### Level A Fully Encapsulated Suit

- \\ Fully encapsulated design to allow breathing apparatus to be worn inside the suit
- \\ Heavy duty 122cm long gas tight zip
- \\ Adjustable internal support belt & bat-wing sleeves
- \\ Flexible, multi-laminated, anti-mist visor
- \\ Seams welded and double taped
- \\ Gloves fitted by means of Respirix locking cuff
- \\ Integral socks with outer splash guard
- \\ Tested to EN464 prior to dispatch
- \\ Pressure tested required annually from year 5 or after each use

### Level B Fully Encapsulated Suit

- \\ Laminated anti-mist visor
- \\ Single exhalation valve to regulate pressure inside the suit
- \\ 117cm Fine tooth zip to rear of suit
- \\ Kemblok™ chemically protective laminated gloves welded to the suit material
- \\ Supplied with Mapa M420 neoprene outer gloves



### Standard Decontamination Shower

- \\ Four shower heads plus an independent hand-held sprayer
- \\ Total output : 16.8 gpm (4.2 gpm per shower head)
- \\ Single water inlet, standard garden hose
- \\ Approximate set-up time : 3 -4 minutes (based on 2 trained responders)
- \\ Meets the flow rates, spray pattern & other performance characteristics set by the ANSI/ISEA 133-2013 standard
- \\ Stored in two vinyl carry bags



# Dräger

## Technology for Life

### Dräger

### Dräger CPS® 7900

Tailor-made for use under extreme conditions: The gas-tight Dräger CPS 7900 provides excellent protection against industrial chemicals, biological agents, and other toxic substances. Its innovative material qualifies the CPS 7900 equally well for work in explosive areas and for handling cryogenic substances.



## Marcé

### Structural Fire Fighting Suit

EN137:2006 Certified

#### Material

- Outer : K -HM02, 240g, Rip-stop
- Moisture : F100SLPTFE
- Thermal Barrier: K-GORNOX
- Inner: M-ST02

#### Coat

- Safety throat tab secures the closure and prevents liquids from entering.
- A convenient wire pocket and an inside pocket on the left chest.
- Two sewed on solid pockets in the front, with reflective tapes across the body of the pockets.
- Anti-wicking strips inside at the end of the sleeves and hem.
- Inside collar loop for easy hanging and thumb loops on the wristlets for preventing items from entering.

#### Trousers

- Cross braces design with adjustable braces buckles and side buckles for comfortable fixation.
- Heavy duty zipper fastens the front opening. It is covered by a storm flap with hook and loop fastener
- Extra reinforcement padding on the knees.
- Anti-wicking strips inside at the end of the pant.
- Inside pocket on the right hip.

[www.marce.co.za](http://www.marce.co.za) | [sales@marce.co.za](mailto:sales@marce.co.za)

# STRUCTURAL FIRE FIGHTING SUITS

NFPA 1971 AND EN469



✓ FIRE HELMETS

✓ P84 BALACLAVA

✓ FIRE FIGHTING GLOVES

✓ FIRE BOOTS

WILDFIRE SUITS  
WILDFIRE HELMETS  
WILDFIRE GOGGLES  
WILDFIRE BALACLAVA  
WILDFIRE MASK & FILTER

THERMAL FIRST ATTACK SUIT  
RESCUE JACKET & TROUSER  
RESCUE GLOVES  
OPERATIONAL BOOTS  
GEAR BAGS

LYMAE cc : 81 Sovereign Drive Route 21 Corporate Park Irene Pretoria  
012 345 5885 | [lymae@mweb.co.za](mailto:lymae@mweb.co.za) | [www.lymae.co.za](http://www.lymae.co.za)



**LYMAE**  
quality protection equipment

# ADVENTURE CLOTHING



NAME TAG  
QUALIFICATION PIN  
PEN & MARKER SLOTS  
REFLECTIVE STRIPS  
ELASTIC WAIST STRAPS

PADDY SUPPORT  
CUSTOM EPPAULETS  
ORGANIZATION SHIELD  
REFLECTIVE STRIPS  
LARGE CHEST POCKET  
SMALL CHEST POCKET

JUMPSUIT - INHERENTLY  
FIRE OR NON FIRE

TACTICAL WEAR

LYMAE cc : 81 Sovereign Drive Route 21 Corporate Park Irene Pretoria  
012 345 5885 | [lymae@mweb.co.za](mailto:lymae@mweb.co.za) | [www.lymae.co.za](http://www.lymae.co.za)



**LYMAE**  
quality protection equipment

# VANGUARD

FIRE & SAFETY

**SERIOUS ABOUT SAFETY**  
A member of the Industrial Safety Services Group

Vanguard is the sole distributor of leading international brands of fire-fighting equipment, apparel and specialised industrial safety products in Africa.

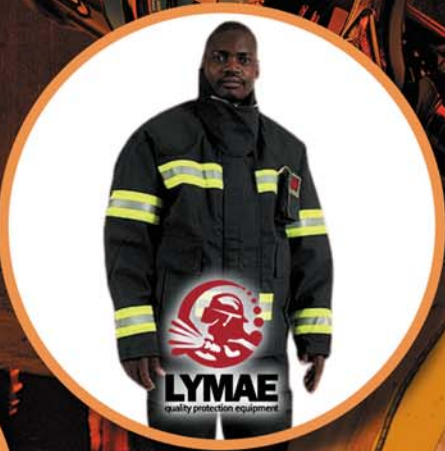

## Buffalo BOA



## Buffalo



## Rockford



## Red Fighter



## Black Fighter



**Aquila Corp is now a proud supplier of quality footwear for the Fire & Rescue Industry!**

**Safety and Occupational Footwear for Firefighters and Emergency personnel**  
- Station wear  
- Wildland Firefighting  
- Structural Firefighting



**Structural Firefighting Boots**  
**Full Grain Leather**  
**Waterproof**  
**FREE-TEX lining**  
**Kevlar shoelaces or BOA Fit System**  
**MICHELIN**  
**Technical Soles**  
**EN ISO 20345:2011**  
**EN 15090:2012**



**AQUILACORP**

Unit 18, Aquaplan Business Park  
120 E.P. Malan Street  
Pomona Kempton Park  
South Africa

[aquilacorpsa.co.za](http://aquilacorpsa.co.za)  
[trtg.co.za](http://trtg.co.za)



# Marcé

## Fire Fighting Boots & Gloves

**Dragon Fire - Alpha X NFPA**  
Full and complete natural leather

**Design**  
Overall anatomically correct ergonomic design

**Safety**  
Excellent cut / rip / abrasion resistant

**NFPA Certified 1971 Standard**

**Grips**  
Functional grips for easy pull on

**Extra Protection**  
Ankle protection

**Protection**  
Steel toe cap

**NFPA Flash Hood**  
Economical option, inherent flame resistant, no harsh chemical treatments, maintains performance values after laundering. Light weight  
NFPA Certified 1971-2013 Standard

**Marcé Leather Fire Fighting Boots**  
Full-grained waterproof leather  
Steel toe cap  
Puncture-resistant steel midsole  
Snug-fitting, soft lining made from real leather  
Full-length, removable SECURA CARE insole  
EN 15090:2012 F2A SRC H13 Certified

# Dräger

## Technology for Life

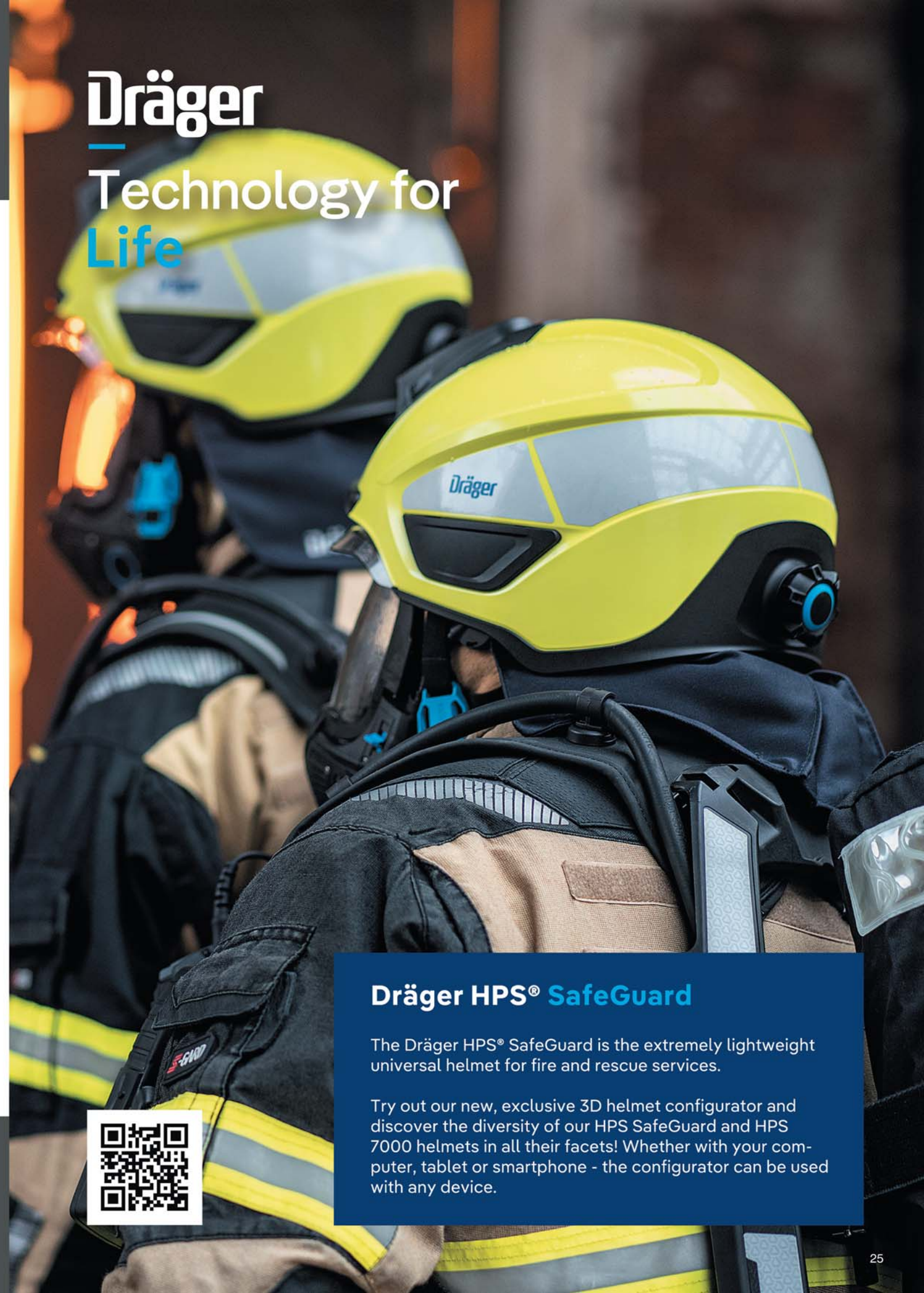

### Dräger HPS® SafeGuard

The Dräger HPS® SafeGuard is the extremely lightweight universal helmet for fire and rescue services.

Try out our new, exclusive 3D helmet configurator and discover the diversity of our HPS SafeGuard and HPS 7000 helmets in all their facets! Whether with your computer, tablet or smartphone - the configurator can be used with any device.





E6000 Multi Gas Detector

**Multi Detection**  
 Detects up to 7 kinds of gases simultaneously

**Application**  
 It's functional and watertight design (IP 66) incorporates a bump proof, rubberised housing to meet the toughest requirements of harsh environments

BX 616 Multi Gas Detector



**Multi Detection**  
 Can detect combustible gas, O2 and two other kinds of toxic gasses simultaneously

**Application**  
 It is widely used in the area where intrinsically safe units are required, like underground channels or mining industry, so as to protect users lives and avoid damage to relevant equipment

BX172 Single Gas Detector



**Gas Detection**  
 Personal Portable gas detector, intrinsically safe design can continuously monitor the gas concentration in the environment

**Application**  
 Widely used in industries like city gas, petrolchemical, fire & safety, vessel industry, oil warehouse, oil station, etc.

SERIOUS ABOUT SAFETY  
 A member of the Industrial Safety Services Group



# How Does Your Health Program Stack Up?



Take Your 10-Minute Health Risk Assessment Today!

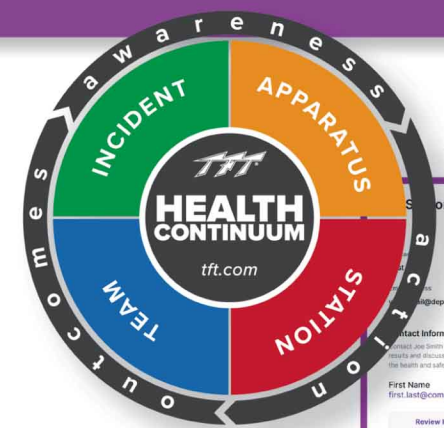

## Awareness to Drive Action and Achieve Your Goals

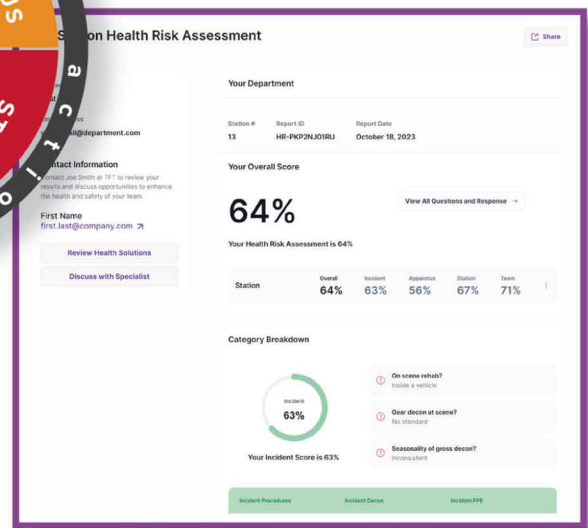

The Health Continuum captures four points of exposure and potential health concerns for your department. These categories encompass the places a firefighter might experience a health risk on duty: station, apparatus, incident, team.

The goal is to provide a framework for you to evaluate and discuss health programs at your department and make it easier to address these concerns while building a comprehensive plan to minimize health risks.

Learn More at [www.vanguardfire.co.za](http://www.vanguardfire.co.za)



# FIRE FIGHTING & RESCUE EQUIPMENT



**Firefighting Hoses**  
UL Listed Rubber and Double Jacket Fire Hoses  
25, 38, 45, 65 and 100mm Hose  
NST, Storz and BIC couplings  
WP 15bar to 28bar



**PPV**  
Airflow 29700 m<sup>3</sup>/h  
Directly mounted to engine shaft  
RPM 3770  
Cowling diameter – 620mm (24")  
10 x high intensity, heat resistant blades – 580mm diameter tip to tip



**Firefighting Nozzles**  
Complete range of Firefighting Nozzles available  
Variable flow, High Pressure, Combination, Curtain and Spear  
NST, Storz and Bic Intakes



**Suction Hoses**  
Available in 4", 5", 5.5" and 6"  
LRT and Storz  
Length's are customized to your needs  
Strainers also Manufactured in all sizes



**Adaptors**  
Single, Double and Triple Dividing and Collecting Breaching's  
NST, Storz and BIC  
4", 5", and 6" pump collecting heads. LRT, BSP, LVT and Storz.



**Floating Pumps**  
"DAMVARK"  
Two models available  
- 750lpm @ 7bar  
- 1000lpm @ 7bar



**Foam Equipment**  
Complete range of Foam making equipment  
- Low Expansion  
- Medium Expansion  
- High Expansion



**Fluorine Free Foam**  
One Foam for all Fires!  
- Class A Fires 0.25% to 1%  
- Class B Polar Solvents 6%  
- Class B Fires Non-Polar Solvents 3%  
- Class D Fires 3 or 6%

**LEGACY AND EXPERIENCE OF OVER 60+ YEARS IN THE FIRE INDUSTRY**



**MULTI PRESSURE VEHICLE MOUNTED PUMPS**  
MFV-MP-1020 2270LPM @ 7BAR  
MFV-MP-1030 3200LPM @ 7BAR  
MFV-MP-1040 4500LPM @ 7BAR  
MFV-MP-1060 600LPM @ 10BAR  
HP 400LPM @ 40BAR  
Conforms to EN 1028 & NFPA 1901



**SMART CONTROL PANEL**  
IP67 Rated HMI Panel  
Digital Display Pump Intake, Discharge and HP  
RPM Control Via Push Buttons  
Engine Monitoring  
Audio & Video Alarms  
Pre-set output for Pump Performance  
RTP push button controls



**PORTABLE PUMPS**  
MFP 275-P 275LPM @ 4.2BAR  
MFP 275 DIEZEL 275LPM @ 4.5BAR  
MFP 800-P 800LPM @ 5BAR  
MFP 1300-P 1300LPM @ 7BAR



Unit 18, Aquaplan Business Park  
120 E.P. Malan Street  
Pomona, Kempton Park  
South Africa  
W | [aquilacorp.co.za](http://aquilacorp.co.za)  
T | +27118231927 or +27826093438  
E | [sales@aquilacorp.co.za](mailto:sales@aquilacorp.co.za)





BS 6391 Certified  
Type 3 Fire Hose  
Made in Germany

**ESCHBACH**



Flat-Form Lifting Bags -  
Provide increased lift with  
improved stability

**Sawa**



The Bullard TXS Thermal Imager is your  
high deployment solution when budget,  
quality, and performance are essential.

**Bullard**



Powerflow Pumps - Big on performance,  
small in size

**GODIVA**



A full range of superior rope rescue &  
height safety equipment

**heightec**  
with respect to gravity...



The Super Vac Nano is the market's  
smallest, most powerful confined space  
blower with ultra compact fabric duct.

**SUPERVAC**



Powerful & portable - From area lighting  
to headlamps - including a range of ATEX  
certified options

**NightSearcher**



The bench mark in pressure and flow  
measurement. Does both dynamic and  
static pressure with optional data-logger

**tsi**  
FLOWMETERS

**BRANCHES**

**FOAM SOLUTIONS**

**PORTABLE MONITORS**



**Twister (DI024/DI040)**  
Dual gallonage nozzle with  
two flow settings



**PRO/pak**  
Portable foam system  
with low or medium  
expansion options



**Crossfire**  
Delivers 4500 l/min with  
exclusive Safe-Tak safety  
shutoff system



**QuadraFog (DQS60P)**  
Unique 5-way Selectable  
flow-rate 25mm Hose  
reel branch



**Inductor**  
Flow-rate from 227 - 950 l/min,  
Induction ratio's at .25% .5%  
1% 3% 6% with Auto-flush  
feature



**Blitzfire**  
Delivers 2000 l/min in standard  
or oscillating options with  
exclusive safety shutoff  
system



**G-Force (GH3N2S)**  
Fully configurable platform.  
Automatic or Selectable  
up to 570 l/min



**QuadraCup**  
Selectable flow nozzle up to 470  
l/min with a retractable foam  
aspiration sleeve



**Hemisphere**  
Delivers 2000 l/min is  
transportable & can rotate  
360° while flowing



## PRODUCT OFFERING

The ELKHART product range includes, amongst others:

- Complete range of handline nozzles
- Manually operated monitors, vehicle mount
- Manually operated portable monitors
- Gate valves
- Standpipe equipment
- Flow test equipment
- Special use nozzles
- Foam tubes and eductors
- EXM2 electric monitors
- Master stream nozzles
- Apparatus valves
- Water powered oscillating monitors
- Nitro HD for mining application
- Standpipe valves
- Field service kits
- XD Smooth bore nozzles
- XD Shutoffs for break apart systems
- Forestry & Wildland nozzles
- Mystery handline nozzles
- Nozzles for marine application
- Nozzles for aviation application
- Cellar nozzles

*Industrial Fire &  
Hazard Control  
– The Home of  
Imageneering*

## Elkhart Brass – Better Equipped, Better Engineered

Understanding the needs of our clients and offering quality products and solutions, sets Elkhart Brass apart. Elkhart Brass is the industry's most experienced manufacturer of innovative firefighting and fire protection equipment. Manufacturing over 2,000 products, used in virtually every aspect of firefighting, makes Elkhart Brass a leader. Our products are found in fire departments around the world, building systems and off-shore drilling sites, as well as in military, marine, mining and petro-chemical, oil & gas firefighting applications. Utilizing some of the country's top engine company instructors, we are checking our emotions at the door and presenting the pros and cons of the relevant engine company topics in the fire service. Part Art. Part Science.

This educational video series will be sure to leave you better informed about nozzles, flows, your fire flow system, and engine company operations as a discipline.

Watch the entire series at: [BrassTacksHardFacts.com](http://BrassTacksHardFacts.com)

Call today for a demo or quotation

*Significantly enhance the  
firefighting capability and  
operational efficiency  
with the inclusion of the  
Elkhart engineered systems  
in your service*



**INDUSTRIAL FIRE**  
& HAZARD CONTROL

For further information please reach out to:

**Trevor Fiford** Cell: 082 651 2580 or email: [trevor@industrialfire.co.za](mailto:trevor@industrialfire.co.za)

**Abrie Dempers** Cell: 078 159 4845 or email: [abrie@industrialfire.co.za](mailto:abrie@industrialfire.co.za)

**Lee Marques** Cell: 061 225 2710 or email: [lee@industrialfire.co.za](mailto:lee@industrialfire.co.za)

**Zarto Williams** Cell: 061 158 6941 or email: [zarto@industrialfire.co.za](mailto:zarto@industrialfire.co.za)



[www.industrialfire.co.za](http://www.industrialfire.co.za)

Proud member of the Advanced Group of Companies



## Advanced Firefighting Technology

Advanced Firefighting Technology GmbH (AFT) is a pioneer in portable, low-pressure water mist & CAFS firefighting systems offering a wide range of innovative water mist & CAFS fire protection extinguishers. The technology creates high-quality water mist at low pressure while ensuring maximum lancing distances for safe firefighting. The technology is adaptable to portable, mobile & fixed firefighting apparatus.

Advanced Firefighting Technology has succeeded in combining the two most natural resources for its extinguishing products: Water and Air. This revolutionary water mist technology outperforms conventional firefighting devices in its efficiency and environmental safety. AFT has grown into a world-leading company in the development and application of innovative low-pressure water mist & CAFS firefighting technology.

Call for specifications a demo today

### BACKPACK SYSTEMS

The portable AFT Firefighting Backpack Systems bring in significant reductions in response time, better accessibility, and effective firefighting thus helping control fires in the initial stages. Up to 40 times more effective than your standard extinguishers. Combine rugged construction and ease of operation and you can be ready for instant response.

### TROLLEYS

With minimal moving parts and corrosion-resistant material, the AFT CAFS firefighting systems are low on maintenance and high on product life. Highest ratings as per European norms making them a perfect firefighting solution for warehouses, logistic centers, workshops, and construction sites where flammable materials are stored or processed.

### MODULAR SKID UNITS

Designed for converting any vehicle to a rapid intervention firefighting system. Highest quality standards and compact in design with a very low center of gravity. The portable products bring in significant reductions in response time, better accessibility, and efficient firefighting thus helping control fires in the initial stages.

*Industrial Fire & Hazard Control – The Home of Imagineering*

*Significantly enhance the firefighting capability and operational efficiency with the inclusion of the Advanced Firefighting Technology in your firefighting fleet.*

### AFT APM CAFS

Easy to operate, wet & dry compressed air foam  
Mobile and easy to transport  
Low Working Pressure: 8.5 bar  
Flow Rate: 24 Litres/min

### AFT MINI MPM FOREST FIRE PUMP

Modular Design and high efficiency  
Integrated Foam Injection System  
Suitable for ATV or Vehicle  
Pressure: 40 bar  
Flow Rate: Max 55 Litres/min

### CUSTOMISED SYSTEMS

CAFS Skid Unit (100-250 Litres)  
Compressed Air Foam Systems (CAFS)  
Custom Skid and Fire Water Packages  
Motor Bike Firefighting Systems



**Diameter**  
38mm, 45mm, 65mm, 100mm

**Resistance**  
Better oil resistance, Abrasion resistant  
Long service life.

**Pressure**  
Working Pressure: 16 Bar  
Testing Pressure: 32 Bar  
Bursting Pressure: 48 Bar

**Couplings**  
British Instantaneous,  
Storz or NST



### Marcé Rubber Hose

Double Rubber Hose.  
Designed especially for Fire Fighting, Chemical Spillage, wash down, water transfer. Marine mining, oil field and construction. Outer Colour : Black, Red or Blue. High Strength polyester filament woven jacket.

**Safety Factor**  
Includes a second closely woven jacket outside for extra durability

### Marcé Double Jacket Hose

Double Jacket Fire Hose.  
Designed especially for hard conditions & high-pressure requirements. Jacket Colour : White. No need to dry after use.

**Design**  
For hard conditions and high-pressure requirements



**Warrior Nozzle NP 115 - 450**

- Strong light weight aluminium construction with a flow rate of 115 - 230 - 360 - 450 Litres per min @ 7 bar.
- Jet Stream and 130 degree wide fog pattern with constant selectable flow rate.
- Available with STORZ, BIC and NST couplings.

**Warrior Nozzle NP 350 - 950**

- Strong light weight aluminium construction with a flow rate of 350 - 450 - 580 - 780 - 950 Litres per min @ 7 bar.
- Jet Stream and 130 degree wide fog pattern with constant selectable flow rate.
- Available with STORZ, BIC and NST couplings.

**Warrior CAFS Nozzle**

- Strong light weight aluminium construction with a working pressure of 7 bar.
- Multi-functional nozzle.
- Available with STORZ, BIC and NST couplings.
- When in flip down position, the nozzle can reach a maximum flow to spray compressed air foam.
- When in flip up position, there are 3 jet types Jet-Fog-Flush.





### **RAM XD Monitor**

- \\ Lightweight, compact monitor easily deployed by single firefighter
- \\ Up & down travel range : Vertical +14 degrees to + 51 degrees (manned)  
+35 degrees to +51 degrees (unmanned)  
Left-Right travel 20 degrees each way (40 degrees total)
- \\ Only 0.6 bar friction loss @ 1900 lpm
- \\ 2.5" Female swivel inlet x 2.5" male outlet
- \\ ideal for quick attack, high-rise & industrial applications
- \\ Lock pin holds valve in closed position preventing accidental opening while moving the unit on a charged hose line
- \\ A safety strap is attached along with a storage pouch



### **Scorpion EXM2**

- \\ Rated for 9500 lpm
- \\ 34.5 bar maximum pressure rating
- \\ 3.5" Male outlet
- \\ Durable, lightweight aluminum construction
- \\ Teflon impregnated, hard coated aluminum finish
- \\ Controls both wired & wireless, provide improved performance & operator control
- \\ Incorporates heavy-duty swivel joints & thrust rods for unprecedented durability
- \\ Travel range : Vertical -45 degrees to +90 degrees (135 degrees)  
Horizontal L175 degrees to R175 degrees (350 degrees)

# Shoring reinvented.



**OmniShore**  
Safety secured.

  
**AQUILACORP**  
Unit 18, Aquaplan Business Park  
120 E.P. Malan Street  
Pomona, Kempton Park  
South Africa  
[aquilacorp.co.za](http://aquilacorp.co.za)  
[trtg.co.za](http://trtg.co.za)

First responders need shoring equipment that is as intuitive, versatile and smart as they are. That is why we have developed OmniShore, a shoring system reimagined from the ground up and designed in accordance with unparalleled standards of quality and safety.

Patented innovations such as the Trident Coupler and OmniLock system allow you to build unlimited applications with less parts, experience a seamless setup with less handling and take full control with less manpower.

Learn more at [holmatro.com/omnishore](http://holmatro.com/omnishore)

 **holmatro**  
mastering power

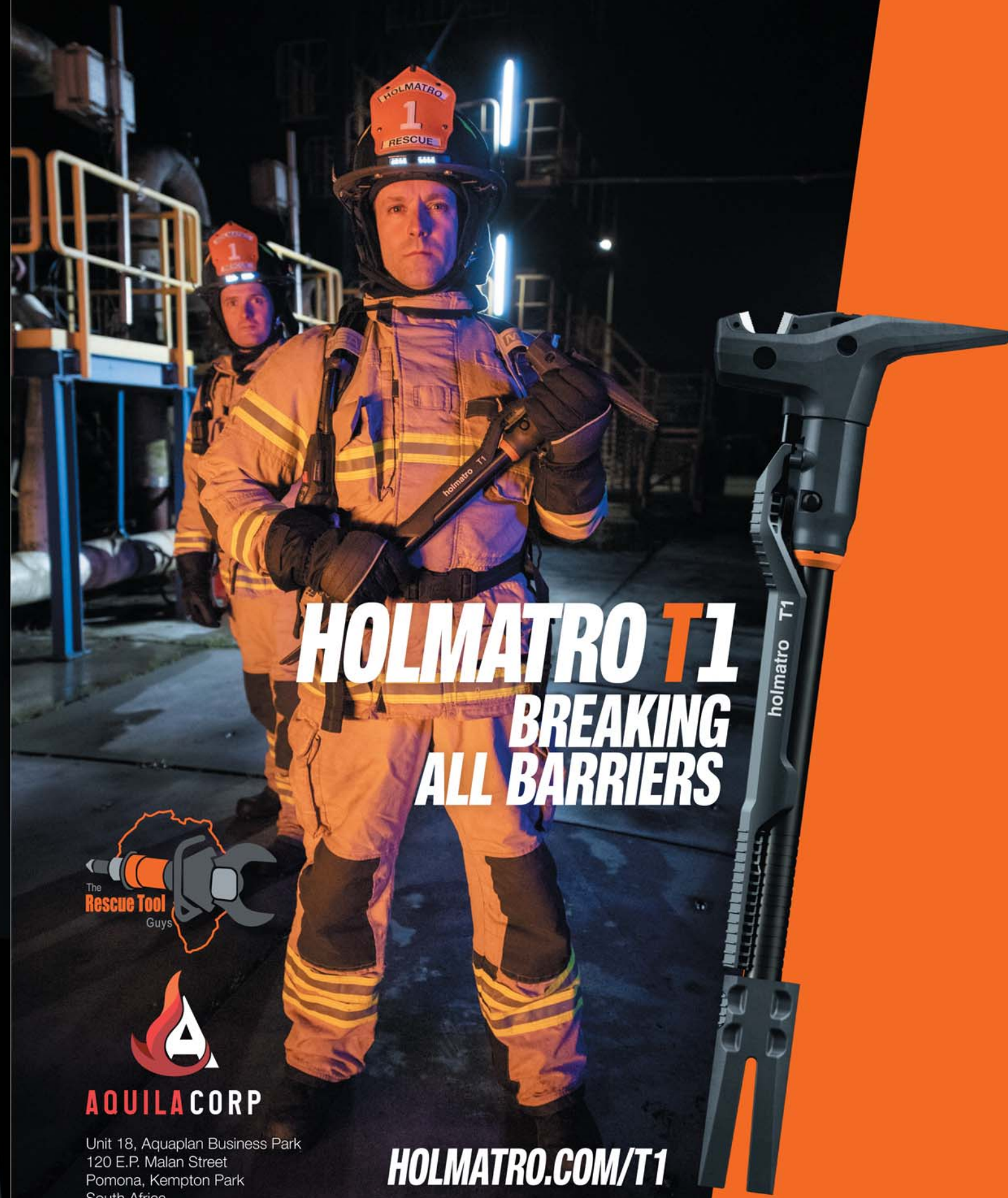

**HOLMATRO T1**  
BREAKING  
ALL BARRIERS



**AQUILACORP**

Unit 18, Aquaplan Business Park  
120 E.P. Malan Street  
Pomona, Kempton Park  
South Africa

[aquilacorp.co.za](http://aquilacorp.co.za)  
[trtg.co.za](http://trtg.co.za)

**HOLMATRO.COM/T1**



**AQUILACORP**

Unit 18, Aquaplan Business Park  
120 E.P. Malan Street  
Pomona, Kempton Park  
South Africa

[aquilacorpsa.co.za](http://aquilacorpsa.co.za)  
[trtg.co.za](http://trtg.co.za)

# PENTHEON



**THE NEXT-GEN PENTHEON SERIES**  
**UNRESTRAINED PERFORMANCE FOR YOUR MISSION**  
FIND OUT MORE ON: [HOLMATRO.COM/PENTHEON](http://HOLMATRO.COM/PENTHEON)

- UNRIVALED PERFORMANCE -

- SUPERIOR USABILITY -

- ADVANCED CONNECTIVITY -

- EXCEPTIONAL SERVICEABILITY -



TNT RESCUE SYSTEMS INC. IS PROUD TO ANNOUNCE THE LAUNCH OF ITS NEW STORM SURGE SERIES BATTERY OPERATED TOOLS, COVERED BY THE SAME GREAT SERVICE AND FOREVER WARRANTY THAT TNT RESCUE HAS BECOME FAMOUS FOR.

**HIGHLIGHTS:**

- Powered by a single Milwaukee M18 battery.
- 60-70 complete cuts with one Milwaukee M18 battery.
- Newly designed 3-stage pump increases the tools speed by 40%
- The tools are capable of maintaining speed through the cut and spread without any degradation in power.
- New aluminum body design for even better durability.
- The Storm Surge series tools are lighter than the existing Storm 2 tools.
- All Surge spreaders feature newly designed removable tips that are wider, much more aggressive, and allow for additional specialty tips.
- The control valve and carry handles are further apart for better control.
- The tools feature 4x LED front lights for better tool positioning at low light.



www.marce.co.za | sales@marce.co.za

WEBER RESCUE SYSTEMS

RURAL METRO EMERGENCY MANAGEMENT SERVICES (PTY) LTD



OFFICIAL WEBER RESCUE AGENCY

SMART FORCE  
MORE THAN A RESCUE TOOL.

+27 (0)33 345 0080 | headoffice@ruralmetrosa.com | www.ruralmetro.co.za





# SUPER X

## TRENCH SHORE KITS

The Super X Trench Shoring System excels in any trench rescue scenario. Machined from high grade aluminum and featuring the same functionality as our Super X-Strut line, the Trench Shoring System will meet all your trench shoring needs. The Super X Trench Shore features a unique positive stop that keeps the inner tube from falling out, and are available in three sizes to accommodate a variety of situations. Each is compatible with our Super X-Strut components, as well as competitor components.

|                          |                     |      |             |             |
|--------------------------|---------------------|------|-------------|-------------|
| <b>2:1 SAFETY FACTOR</b> | <b>SHORING WALL</b> | 26"  | 38,000 Lbs. | (17,236 Kg) |
|                          | At various lengths* | 50"  | 30,600 Lbs. | (13,880 Kg) |
|                          |                     | 74"  | 25,150 Lbs. | (11,408 Kg) |
|                          |                     | 94"  | 14,180 Lbs. | (6,432 Kg)  |
|                          |                     | 112" | 10,400 Lbs. | (4,707 Kg)  |



### 8-Point Trench Shore Kit

**Kit Contents:**

- (2) 38"/96.5 cm. Trench Shores
- (4) 28"/71 cm. Trench Shores
- (2) 18"/46 cm. Trench Shores
- (2) 36"/92 cm. Extensions
- (2) 24"/61 cm. Extensions
- (2) 12"/31 cm. Extensions
- (12) Swivel Plates
- (4) Flat Plates
- (1) Air Inflator Kit (not pictured)

Super X 8-Point Trench Shore Kit

### 6-Point Trench Shore Kit

**Kit Contents:**

- (4) 28"/71 cm. Trench Shores
- (2) 18"/46 cm. Trench Shores
- (2) 24"/61 cm. Extensions
- (2) 12"/31 cm. Extensions
- (8) Swivel Plates
- (4) Flat Plates
- (1) Air Inflator Kits (not pictured)

Super X 6-Point Trench Shore Kit



### 12-Point Trench Shore Kit

**Kit Contents:**

- (2) 38"/96.5 cm. Trench Shores
- (6) 28"/71 cm. Trench Shores
- (4) 18"/46 cm. Trench Shores
- (2) 36"/92 cm. Extensions
- (2) 24"/61 cm. Extensions
- (2) 12"/31 cm. Extensions
- (18) Swivel Plates
- (6) Flat Plates
- (1) Air Inflator Kit (not pictured)

Super X 12-Point Trench Shore Kit



**PRODUCTS  
THAT  
SAVE LIVES**

# Marcé USAR

## USAR POWER TOOL KIT

Our new USAR power tool kit not only provides all the power of corded and petrol-powered light equipment, but also produces ZERO EMISSIONS.

With the elimination of fumes and emissions with this new platform, this allows the user to improve their carbon footprint, as well as improving health and safety, as harmful fumes, noise and vibrations associated with the running of this light equipment are eliminated.

As a result, this increases productivity as this allows users to work indoors, in trenches, in tunnels or even in mines, without any petrol headaches. This new system not only saves the end user time with refuelling and starting up, but provides a cost saving on petrol consumption and engine maintenance.

### Kit Consists of the following tools:

- MX FUEL 350mm Cut-Off saw
- MX Fuel 150mm Core Drill
- M18 230mm Cut-Off saw
- M18 190mm Circular saw
- M18 Deep Cut Band saw
- M12 Inspection Cam
- M18 Impact Driver
- M18 Water supply tank with pump
- MX Fuel 25kg Demolition Hammer
- M18 300mm Chain Saw
- 2 x M18 2000Lumen Area Lights
- M18 115mm Angle grinder
- M18 34 degree Nail gun
- M18 Percussion drill
- 2 x M18 Combination Drill and Breakers
- M18 Super Sawzall Reciprocating saw

\*All tools supplied with Blades and storage cases

# ZERO EMISSIONS

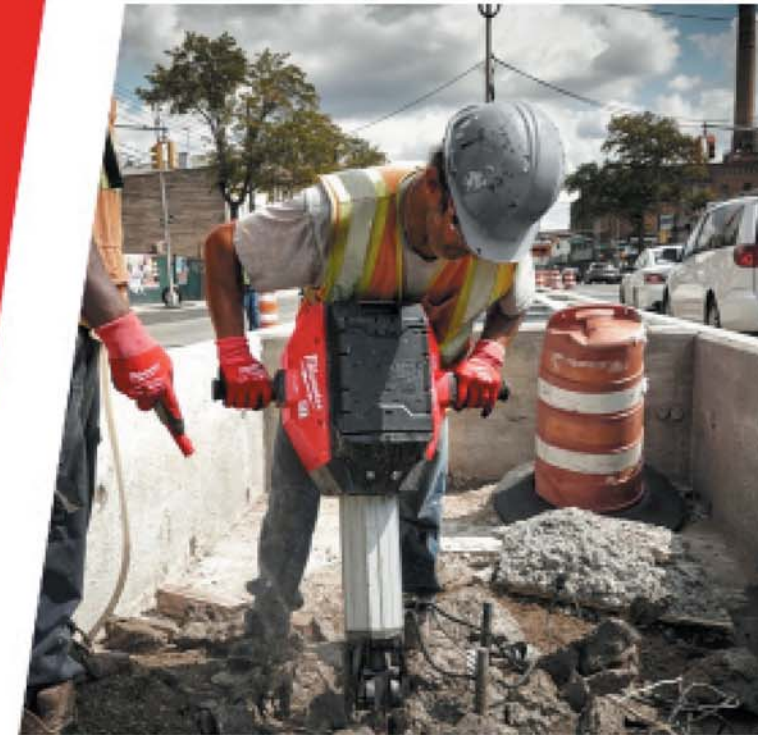

**Marce**

[www.marce.co.za](http://www.marce.co.za) | [sales@marce.co.za](mailto:sales@marce.co.za)



### Search & Rescue Wetsuit

- \\ 4mm Red / Yellow super stretch neoprene construction
- \\ Triple glued, blind stitched seams
- \\ YKK Zipper
- \\ Padded knee, elbow and seat protection
- \\ Large yellow Rescue logo
- \\ Smooth skin neck, wrist and ankle seals
- \\ Moulded collar



### Inflatable walkways / Paths

- \\ Available in 2m, 5m, and 10m lengths
- \\ Material : 15cm drop stitch and PVC
- \\ Four lifting handles
- \\ D-ring attachment point in each corner
- \\ Multiple D-ring attachment points on each end & side
- \\ Anti-slip surface
- \\ 2 Side pouches to hold equipment

### EVO X PDF

- \\ 40mm Removable chest harness
- \\ Quick release fix-back buckles
- \\ Front entry
- \\ Cowtail and carabiner
- \\ Padded adjustable shoulder straps
- \\ Narrow reflective piping
- \\ Tough grip shoulder panels
- \\ Front and rear 4-way lash tabs
- \\ Plastic D-rings
- \\ Zipped front pouch
- \\ Removable PDF whistle
- \\ Removable Flexi-light pocket
- \\ Reinforced stitching strenghtens high wear areas
- \\ Supplied in drawstring storage bad





**RESCUE CACHE PRO**  
Designed for the professional rope rescuer—contains all the components for a basic high angle rescue system



**RESCUE CACHE AUTOLOCK PRO**  
Designed for the most up-to-date twin-tensioned rope rescue techniques

**ANEXK9 HARNESS**  
Available in small, medium and large  
Vertical lift harness, designed to securely raise or lower your working dog



**CASCADE TERRA TAMER TRANSPORT WHEEL**  
26 x 4.75" all-terrain wheel  
The Terra Tamer is an exceptionally light, obstacle crushing wheel that fits on any litter using a rapid attachment system



**HAULERBINER COMPACT RESCUE SYSTEM**  
This compact kit can be worn on the harness and used for pick-offs in work at height and rope access rescues

**VECTOR**

3 lbs 1 oz, 47.73 inches  
This monopod has been designed and engineered as a light-weight, portable tool for use in industrial, mountain and urban rescue environments

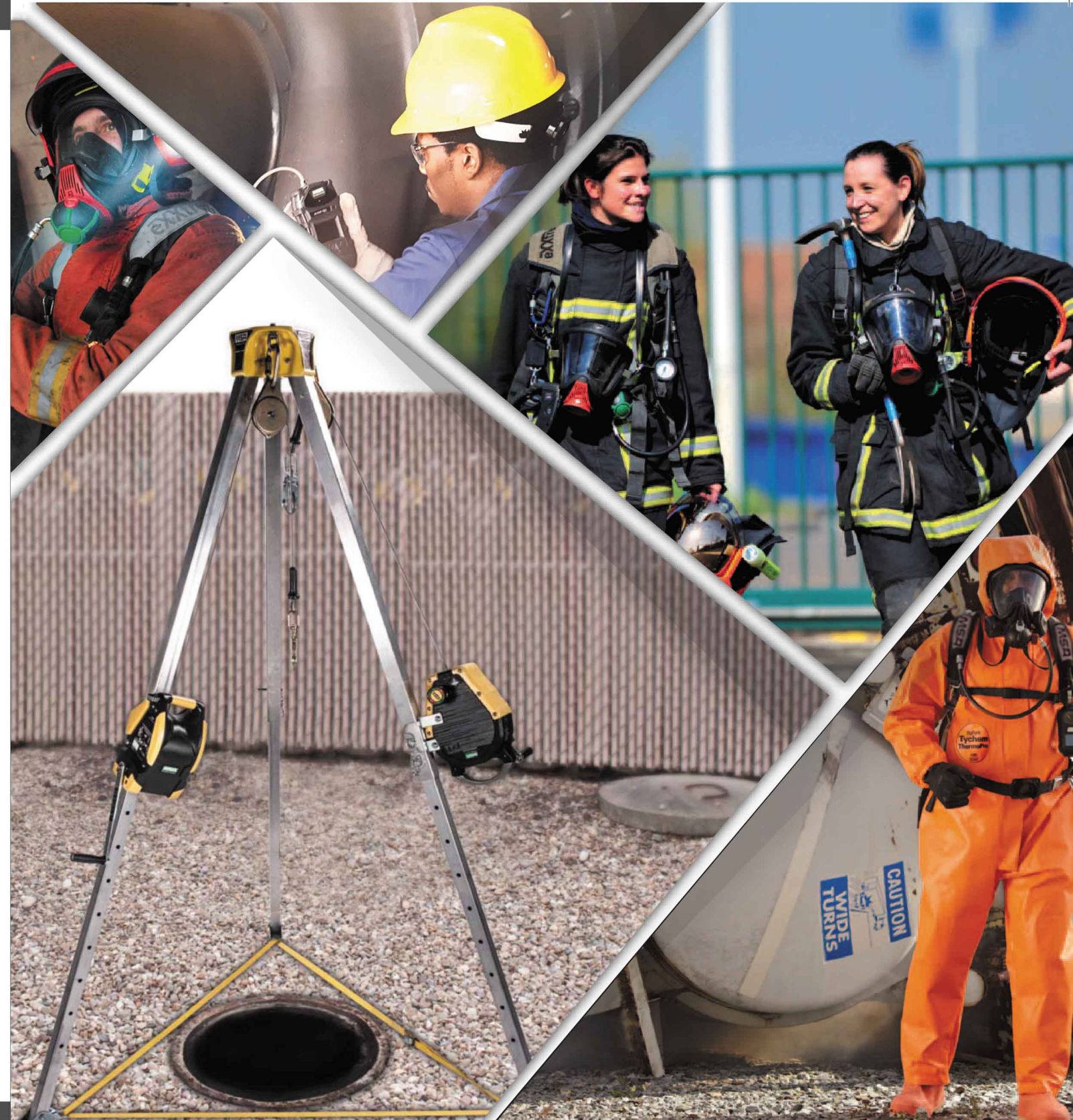

# Dräger Technology for Life



## Dräger PARAT® 1260 Filtering Escape Device

Designed with simplicity in mind, the Dräger PARAT® 1260 is an extra small mouthpiece / nose clip filtering escape device equipped with a multi-gas ABEK filter that offers you 10 minutes of protection against a variety of toxic industrial gases and vapours.



**"Risk comes from not knowing what you're doing"**

*Warren Buffet*

**Second updated edition is now available**

**Risk Assessments: A Guide to Understanding the Basics**

*is an invaluable aid to discovering how competent risk assessments identify the risks to be mitigated.*

**[www.safety1st.co.za](http://www.safety1st.co.za)**



*Published by the*

**Safety First Association**

Email: [debbie@safety1st.co.za](mailto:debbie@safety1st.co.za) / Tel: +27 (11) 886-5985 / Mobile: +27 (83) 266-6662

## **Risk Assessments:**

**Guide to Understanding the Basics**

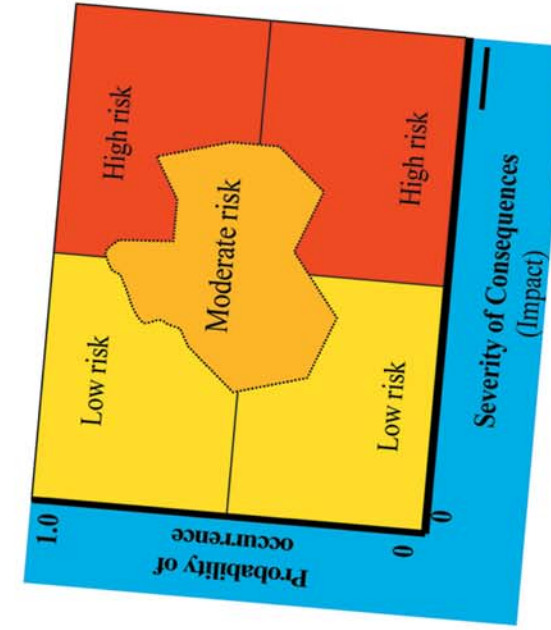

Second Edition

Author:  
Leighton Bennett

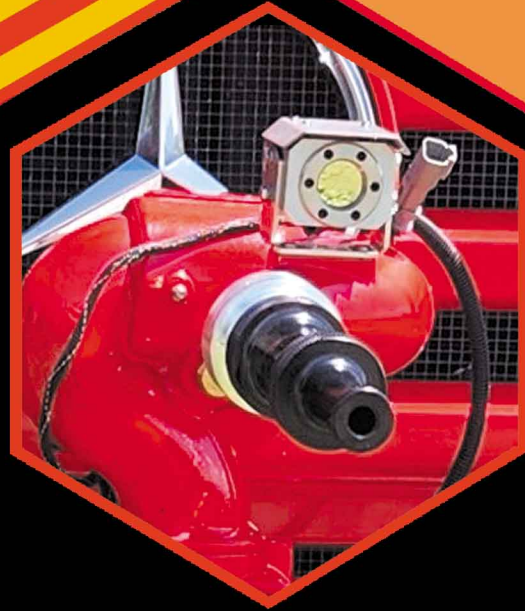

## HYPERSIGHT Thermal Imaging Camera

Analyzing the situation quickly, directing the attack where most needed, and knocking down the fire as fast as possible without endangering lives is the goal. HYPERSIGHT makes this work easier by letting firefighters see the heat from the vehicle. The leading edge can be evaluated, and areas of most concern worked first. Hot spots are detected and addressed faster reducing rekindles and additional work.

HYPERSIGHT sees through smoke to know where the fire is ... and where it isn't.

This enhanced situational awareness helps direct the attack and enable the quickest escape when needed. In the heat of battle knowing the location of ground crew near vehicles is critical. When enveloped in smoke this task becomes nearly impossible and many times the worst happens. In addition, just keeping a wildland vehicle in action is no easy task. Many brush trucks are knocked out of service by ravines, boulders, trees, not to mention other vehicles, that simply couldn't be seen. HYPERSIGHT erases smoke from the drivers' vision allowing them to navigate safely and avoid costly, even deadly accidents.

Call today for a demo or quotation.

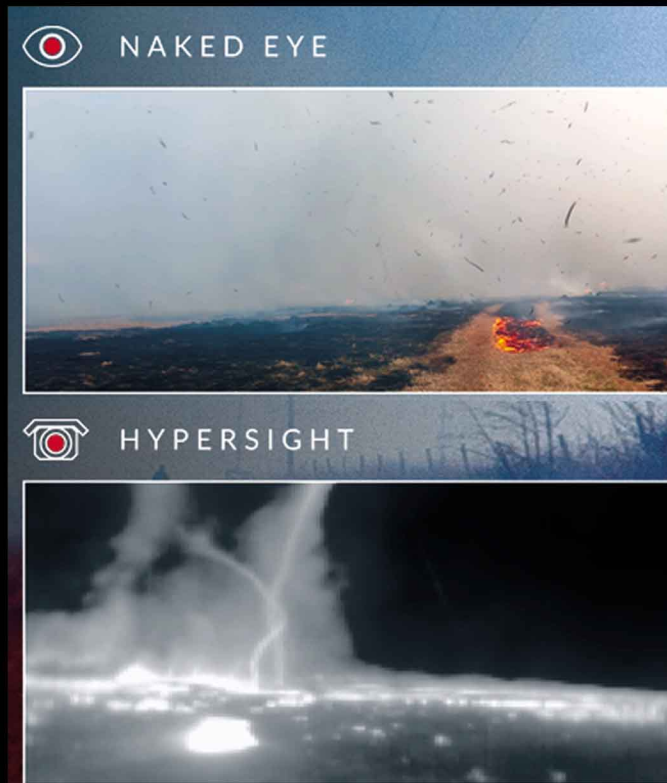

## SPECIFICATIONS

The HYPERSIGHT offers the following features

- Manufactured in the USA
- Designed for firefighters
- Rugged and designed to withstand temperatures and physical abuse
- Delivers mission critical data
- HYPERSIGHT 160R offers a resolution of 160 x 120
- HYPERSIGHT 320 enhances with a higher resolution of 320 x 240
- Visualises fuel levels in tank batteries that cannot be seen with the naked eye
- Sees through smoke
- Helps determine escape routes in dense smoke conditions
- Used for collision avoidance at fire incidents
- More efficient fire suppression
- Ideal for search and rescue
- Improve navigational safety
- Fight fires faster
- Crisp detail and responsive imagery
- Long Wave Infrared Sensor
- 60Hz frame rate
- Weatherproof
- Stainless steel body
- Operates in temperatures from -40°C to +85°C
- NTSC format
  - Shutterless design

*Industrial Fire & Hazard Control  
– The Home of Imagineering*

*Significantly enhance the firefighting capability and operational efficiency by mounting the HYPERSIGHT Thermal Imaging Camera on your firefighting and rescue fleet.*

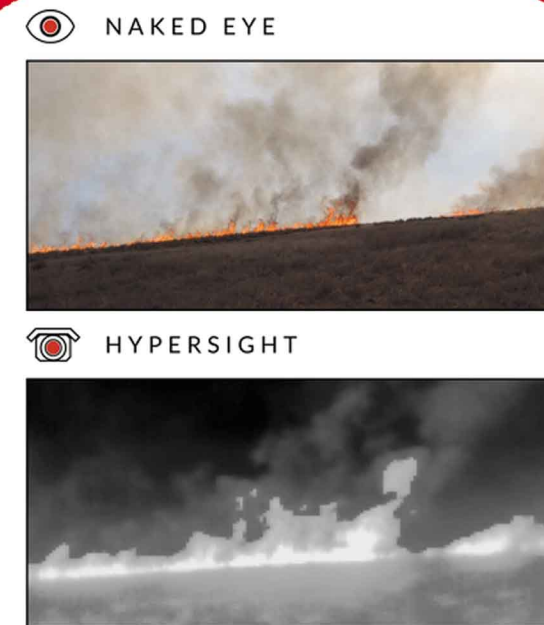

## TRAINING ACADEMY

The Rural Metro Academy is a world-renowned fire training facility. The Academy specializes in training structural and industrial firefighters. We are a customer focused organization committed to delivering high quality training and education in a congenial environment.

Offering the following courses:-

- Firefighter 1 (NFPA 1001)
- Firefighter 2 (NFPA 1001)
- Hazmat Awareness (NFPA 472)
- Hazmat Operations (NFPA 472)
- Fire Instructor 1 (NFPA 1041)
- Fire Officer 1 (NFPA 1021)

Specialized Training: -

- Breathing Apparatus
- Confined Space Training
- Industrial Firefighting
- Chlorine and Ammonia Handling
- High Angle / Rope Rescue
- Vehicle Extrication
- Conduct Fire Safety Inspection
- Swift Water Rescue
- Wildfire Suppression
- HAZMAT Supervision (Technician)
- Fire Investigator
- Driver Pump Operator



## RESCUE SOUTH AFRICA



### | URBAN SEARCH & RESCUE TRAINING | | DISASTER RESPONSE |

Rescue South Africa is an NGO, non-profit organisation with the most comprehensive cache of rescue equipment in Sub-Saharan Africa making us the only service provider with the ability to travel anywhere in Sub-Saharan Africa to deliver training.

- |   |  |  |  |
|---|--|--|--|
|   |  |    |    |
| <b>BASIC RESCUE PRACTITIONER</b>  | <b>BRIDGING COURSE</b>   | <b>WILDERNESS SEARCH &amp; RESCUE PRACTITIONER</b>   | <b>URBAN SEARCH &amp; RESCUE PRACTITIONER</b>  |
| <ul style="list-style-type: none"> <li>• High Angle 1 Rescue</li> <li>• Fire Search &amp; Rescue</li> <li>• Motor Vehicle Rescue</li> <li>• Industrial &amp; Agricultural Rescue</li> </ul> | <ul style="list-style-type: none"> <li>• High Angle 2 Rescue</li> </ul>              | <ul style="list-style-type: none"> <li>• Aquatic Surface Rescue (Swift Water &amp; Small Boat Handling)</li> <li>• Aviation Rescue</li> <li>• Confined Space Rescue</li> <li>• Wilderness Search &amp; Rescue</li> </ul> | <ul style="list-style-type: none"> <li>• Hazardous Materials Rescue</li> <li>• Confined Space Rescue</li> <li>• Trench Rescue</li> <li>• Structural Collapse Rescue</li> </ul> |



### MEMBERSHIP AND ACCREDITATION



[www.ruralmetro.co.za](http://www.ruralmetro.co.za)

Should you wish to **up-skill** in emergency services /  
Would like more information on how to develop a  
Rescue **Proto Team** /  
For any **Rescue Training needs**  
**Please contact us:**

**Call:** +2782 459 9765

**Email:** [ian@rescue-sa.co.za](mailto:ian@rescue-sa.co.za)

[www.rescue-sa.co.za](http://www.rescue-sa.co.za)



# Marce 4x2 Rapid Intervention Vehicle

[www.marce.co.za](http://www.marce.co.za) | [sales@marce.co.za](mailto:sales@marce.co.za)



## FEATURE-PACKED

### Cab & Chassis

- Mercedes Benz Sprinter 519CDI
- 4x2 140kW @ 3800 rpm
- Automatic transmission
- Double cab seats driver plus 4

### Ancillary equipment & fixtures

- Hydraulic Rescue equipment
- Fire fighting equipment
- LED illumination for lockers
- Robotic lightmast c/w 2 x LED lights

### Fire Fighting System

- Ultra High Pressure Pump
- 42 l/min @ 100 bar
- Water tank : 1000 litre
- Foam tank : 100 litres Class A
- Manual Pump control system
- Manual ATP Foam system
- LED tank level gauges
- One hose reel each side c/w nozzle







# Marcé 4x4 Scania HD Pumper

[www.marce.co.za](http://www.marce.co.za) | [sales@marce.co.za](mailto:sales@marce.co.za)



## FEATURE-PACKED

### Cab & Chassis

- \\ Scania P 360 B4x4HZ CP28L
- \\ 360 HP
- \\ Fully automatic Allison transmission
- \\ Seats driver plus 5 with 4 SCBA seats in rear
- \\ Scania OEM 4 door all steel double cab

### Pump discharges

- \\ Four normal pressure rear facing manual discharge outlets
- \\ Two high pressure outlets to hose reels
- \\ One discharge to deck monitor

### Fire Fighting System

- \\ Centrifugal pump 3000 l/min @ 10 bar NP & 250 l/min @ 40 bar HP
- \\ Manual ATP foam system
- \\ Water tank : 5000 litre
- \\ Foam tank : 500 litre
- \\ Manual operated deck monitor (can be electric)

### Ancillary equipment & fixtures

- \\ Marcé fire fighting tools & equipment
- \\ Hydraulic rescue tools
- \\ Top mounted pull down ladder gantry



# Marcé 6x6 Rapid Attack Pumper

[www.marce.co.za](http://www.marce.co.za) | [sales@marce.co.za](mailto:sales@marce.co.za)



## FEATURE-PACKED

### Cab & Chassis

- \\ Toyota Land Cruiser Single cab
- \\ 6x6, 4.5l V8, 151kW @ 3200 rpm
- \\ Full 6x6 suspension upgrade
- \\ Powerbrake upgrade
- \\ Tyre and rim upgrade

### Emergency lighting & siren

- \\ Red LED bar
- \\ Red LED flashers on vehicle
- \\ 100w PA and siren system

### Fire Fighting System

- \\ Single Stage Centrifugal PTO driven pump
- \\ Manual ATP Foam System
- \\ 380 l/min up to 36 bar
- \\ Water tank : 1425 litre
- \\ Foam tank : 75 litre
- \\ Marcé Electronic pump control

### Pump discharges

- \\ Two 65mm discharges with BIC couplings
- \\ Marcé Electronic Monitor foam capable
- \\ Two discharges to hose reels



# Introducing the **DELUGE** System

from



**INDUSTRIALFIRE**  
& HAZARD CONTROL



## The Industrial Fire & Hazard Control “DELUGE” System

Industrial Fire & Hazard Control, a proud member of the Advanced Group of Companies, in collaboration with Williams Fire & Hazard Control, has engineered and built the ultimate in high-capacity firefighting water supply systems to cater for every eventuality. Mitigating the most extreme and dangerous fire incidents by applying overwhelming fire suppression power is our business.

### Firefighting Operations:

Extreme fire risks in the petrochemical, oil and gas incidents requires robust emergency planning and an effective response which, by its very nature, requires specialised equipment, equipment that must exceed the sheer magnitude of these fire incidents.

The biggest challenge in the response capability has always been the continuous and sufficient supply of water to feed the multitude of delivery apparatus.

This challenge is now something of the past with the introduction of the “DELUGE” system.

Call for specifications or a demo today

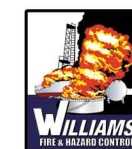



### Flood situations

The "DELUGE" system is essential during flood situations and is ideal for managing and controlling excess water thereby mitigating the impact of floods and protecting lives and property as well as the environment. The "DELUGE" system can rapidly reduce water levels with flows up to 53,000 l/min (3,000,000 litres in 60 minutes) thus preventing structural damage to buildings and infrastructure; ensuring public safety; facilitating Emergency Response and assisting in economic recovery.

### Wildland Fires

The "DELUGE" system plays a key role in supplying water for firefighting operations in wildland fires. The system ensures that firefighters have water resources at the fire front to ensure rapid fire suppression; the system supplies water for cooling hotspots and for mopping up operations; the system is ideal for structural protection that requires increased volumes of water; the system easily provides a water source for (MAFFS) modular airborne firefighting operations); the system is the backbone for hose lay operations and further ensures the safety of firefighters.

*Industrial Fire & Hazard Control  
– The Home of  
Imageneering*

### The "DELUGE" high volume water supply system offers the following unique operational characteristics:

- "SURGEMAX" high volume submersible pumps – 30,000 l/min from a water source up to 61m away from the "DEPENDAPOWERS" and with a vertical lift of 10.6m. Total capable lift is 40m.
- "DEPENDAPOWERS" high volume booster pump – 30,000 l/min from submersible pumps or 53,000 l/min from draft AND submersible pumps.
- "MEGALIFT" ultra load hook loading system – hydraulic hook loader system for lifting and lowering the "DEPENDAPOWERS" system incorporating the "SURGEMAX" hydraulic submersible pumps.
- "TITANHOOK" pro-lift crane system with a lifting capacity of 1950kg at 6m and 590kg at 16m.
- "ANNACONDA" high volume automated hose retrieval system, capable of housing 5km of "MEGAFLOW" 304mm high volume hoses. The "ANNACONDA" is fitted with two (2) "HOSEMULES" that automatically retrieve the hoses. The "ANNACONDA" is fitted with a tail lift allowing the hoses to be "driven" out.
- "MAXSTREAM" high volume flow manifold system allows for the connecting of 304mm "MEGAFLOW" supply lines and 184mm and 152mm discharge lines.



### Fire Suppression Systems

Water supply is a critical element for the effectiveness and reliability of fixed fire suppression systems. It is essential for these systems to fulfill their role in preventing and mitigating fire-related risks in a wide range of settings. In the event that an existing system is taken out of service for maintenance/repair/replacement, the "DELUGE" system can operate as a "stand-in" system or can fulfill the role of the water supply system for a suppression system as a permanent supply in remote areas.

### Water Supply in Drought Conditions

The "DELUGE" system is an imperative requirement for supplying high volumes of water over very long distances during times of drought. The "DELUGE" system will ensure a water supply system for firefighting operations; the system can be used as a distribution system for water supply to residential, agricultural or industrial areas, including airports and other key points; the system is an ideal transfer system and can ensure the replenishing of reservoirs and dams.

*Significantly enhance the firefighting capability and operational efficiency with the inclusion of the Deluge system in your firefighting fleet.*



### The "DELUGE" system comprises the following components:

- The "DELUGE" system comprises the following components:
- "SURGEMAX" high volume submersible pumps
  - "DEPENDAPOWERS" high volume booster pump
  - "MEGALIFT" ultra load hook loading system
  - "TITANHOOK" pro-lift crane system
  - "ANNACONDA" high volume automated hose retrieval system
  - "MEGAFLOW" 304mm high volume hoses
  - "MAXSTREAM" high volume flow manifold system

For further information please reach out to:

**Trevor Fiford** Cell: 082 651 2580 or email: trevor@industrialfire.co.za

**Abrie Dempers** Cell: 078 159 4845 or email: abrie@industrialfire.co.za

**Lee Marques** Cell: 061 225 2710 or email: lee@industrialfire.co.za

**Zarto Williams** Cell: 061 158 6941 or email: zarto@industrialfire.co.za



www.industrialfire.co.za

Proud member of the Advanced Group of Companies



## SPECIFICATIONS

The technology designed into the Double Assassin was perfected in the Petro Chemical Oil & Gas industry, an industry that is faced with the most extreme of fire conditions.

The Double Assassin has the following built-in advantages to assist in the mitigation of fire incidents:

- Heavy duty dual axle trailer
- 680 litre pre-mix tank (water & foam)
- 135 kg Purple K DCP
- Nitrogen compartment to store 4 x Nitrogen cylinders
- Hydro-Chem™ attack lines with 2 x 15m x 25mm attack lines (water/foam & DCP)
- Williams Hydro-Chem™ nozzle (triple agent)
- Stainless steel plumbing
- All aluminium compartment
- Rear mount operators panel
- Tank mounted monitor with stacked tip
- 38mm flaked attack line
- Twin hose bed
- 4 x 600kg stabilisers
- Access steps
- Array of equipment

*Industrial Fire &  
Hazard Control  
– The Home of  
Imagineering*

## Double Assassin Fire Response Trailer

The Double Assassin Firefighting Trailer is specifically designed for versatility in operation, allowing responders to mitigate a multitude of risks. Time management in the event of a fire incident, is critical and the Double Assassin is pre-charged to allow immediate application of extinguishing agents to be brought to bear on the fire without any time delay. The Double Assassin includes Hydro-Chem™ technology that allows it to punch way above its category.

The Double Assassin can be towed by a standard pick-up which ensures that there are no restrictions in availing the unit during an incident. The design of the Double Assassin is such that the unit can be serviced and maintained by a local service centre and requires no special tools for serving. The Double Assassin, designed by firefighters for firefighters!

Call for specifications or a demo today

*Significantly enhance the  
firefighting capability and  
operational efficiency  
with the inclusion of the  
Double Assassin in  
your firefighting fleet.*

## SUITABLE FOR OPERATION IN

- Mines
- Airports (up to Category III)
- Municipal and Local Authorities
- Light industry
- Chemical plants
- Mineral operations
- Forestry
- Factories
- Manufacturing facilities
- Hazmat facilities
- Highway patrol
- Ports authorities
- Game farms
- Railway stations
- Heliports
- Military installations
- Petro-Chemical, Oil & Gas facilities
- Pipeline protection
- Construction sites



For further information please reach out to:

**Trevor Fiford** Cell: 082 651 2580 or email: [trevor@industrialfire.co.za](mailto:trevor@industrialfire.co.za)

**Abrie Dempers** Cell: 078 159 4845 or email: [abrie@industrialfire.co.za](mailto:abrie@industrialfire.co.za)

**Lee Marques** Cell: 061 225 2710 or email: [lee@industrialfire.co.za](mailto:lee@industrialfire.co.za)

**Zarto Williams** Cell: 061 158 6941 or email: [zarto@industrialfire.co.za](mailto:zarto@industrialfire.co.za)





## WHY THE BLITZ PYROUHP

The BLITZ PyroUHP offers the following distinct advantages over traditional firefighting operations.

- Can be mounted onto any chassis cab with a +3500kg GWW
- Can be mounted on a single cab or double cab chassis
- Degree of efficiency of traditional firefighting methodologies is estimated at between 10 to 20% (up to 90% of water applied has no extinguishing effect). The effectiveness of the PyroUHP technology is estimated at 90-95%
- The USA Air Force Civil Engineering Centre test report on the PyroUHP proved that the system used 45% less water than traditional systems
- The use of PyroUHP application resulted in faster room cooling
- The PyroUHP used 1/5th the amount of water for de-smoking (hydraulic ventilation) than traditional systems
- The fully charged 19mm discharge line is lighter and easier to work with when compared to traditional discharge hoses
- The tests show that "greater than 300% improvement in fire fighting efficiency can be obtained using PyroUHP"
- Arrive early & hit hard
- PyroUHP allows for precision of attack
- The PyroUHP offers minimal water damage
- The PyroUHP minimises environmental impact and collateral damage
  - Minimum number of first responders are required to operate the unit
  - The application of the PyroUHP technology prevents exposure to carcinogens

*Industrial Fire & Hazard Control – The Home of Imagination*

## BLITZ - PyroUHP

The USA Air Force Research laboratory has spent significant time and resources in testing PyroUHP against traditional firefighting systems and standard UHP. The findings are significantly in favour of PyroUHP and the effect that this technology has on Class A and Class B fires.

The PyroUHP system offers a faster and safer attack and is ultimately more effective than traditional firefighting systems. As firefighters operate in the "time management space" - faster response ensuring firefighting operations are undertaken without any time delay – this is the added advantage of the PyroUHP.

The future of firefighting is Rapid Response units (R<sup>2</sup>).

Call for specifications or a demo today



*Significantly enhance the firefighting capability and operational efficiency with the inclusion of the BLITZ PyroUHP in your firefighting fleet.*



- Lower capital cost solution when compared to traditional firefighting units
- The PyroUHP offers greater firefighter safety, less exposure to smoke, heat and steam
- The PyroUHP application lowers the risk of flashovers & backdrafts
- The PyroUHP technologies allows greater emphasis on controlling the gas phase of the fire instead of just focusing on the fuel phase
- The PyroUHP breaks down traditional water droplets in 64 micro droplets which covers 10-12 times the surface area of traditional systems
- The PyroUHP technology offers immediate thermal conversion of water to steam absorbing heat quicker
- The micro droplets, delivered at high-energy, displaces oxygen
- The presence of the fine water droplets effectively disperses radiant heat and reduces flame velocity.
- Conversion of fine water droplets effectively raises the humidity to 30% and above in which the fire cannot be sustained.
- The micro droplets allow for a longer "hang time" in the atmosphere
- The speed (velocity) of the micro droplets greatly influences the absorption of heat
  - The PyroUHP offers both Class A and Class B foam application for increased versatility



## SPECIFICATIONS

The CAFS Wildland Interface Pumper offers the following base specifications (the unit can be adapted to suit specific or bespoke needs)

- 18,000kg GVM chassis cab with 4x4 capability
- Available in single or double cab
- 5000 litre polypropylene water tank
- 250 litre Class A foam tank
- 250 litre Class B foam tank
- Darley Hornet Compressed Air Foam System, rear mounted
- Darley HM 500 PTO driven pump, side mounted
- FoamMate foam system
- Side mounted pump panel
- Stainless steel plumbing
- All aluminium superstructure manufactured using large dimensional extrusions
- Three (3) large compartments each side with roller shutter doors
- Slide out steps for ease of access to the furthest reaches of the compartments
- Bumper mounted Elkhart BrushHawk remotely operated turret
  - Handheld remote control for operation up to 30m from the pumper
- Deck gun, Elkhart SideWinder, remotely operated in the cab
  - HyperSight thermal imaging camera, front mount

*Industrial Fire & Hazard Control – The Home of Imagineering*

## CAFS Wildland Interface Pumper

The CAFS Wildland Interface Pumper is a highly effective pumper for the mitigation of a range of fires over varied industries. The CAFS WIP is engineered and manufactured to assist firefighters in extinguishing Class A and Class B fires in everyday or remote locations.

The versatility of the CAFS WIP is founded in the application of Compressed Air Foam Systems as well as a traditional PTO driven side mounted pump. These two pumping methodologies can be applied simultaneously in a fire attack or individually selected depending on the incident.

The 4x4 capability of the chassis cab allows the CAFS WIP to navigate extreme conditions.

Call for specifications or a demo today



*Significantly enhance the firefighting capability and operational efficiency with the inclusion of the CAFS Wildland Interface Pumper in your firefighting fleet.*



- Electric foam transfer pump for tank refilling
- Pump control panel in cab with all controls and gauges
- Front spray bar, in-cab controlled
- Cab spray bar to protect the cab, in-cab controlled
- Under truck nozzles, in-cab controlled
- Twin hose reels with 30m x 25mm hose and selectable pistol grip nozzle
- 38mm preconnect attack line for CAFS
- Adjustable shelves in all compartments
- Rear view camera
- Two (2) 65mm discharges
- One (65mm) tank fill inlet
- Automotive paint finish with 3-year warranty
- Five (5) year superstructure warranty
- Front mount electric winch
- Heavy duty bull bar
- Safety hand rails all-round, stainless steel
- Fold down rear step
  - Array of equipment that can be supplied and mounted in accordance with the client's specification



For further information please reach out to:

**Trevor Fitorf** Cell: 082 651 2580 or email: [trevor@industrialfire.co.za](mailto:trevor@industrialfire.co.za)

**Abrie Dempers** Cell: 078 159 4845 or email: [abrie@industrialfire.co.za](mailto:abrie@industrialfire.co.za)

**Lee Marques** Cell: 061 225 2710 or email: [lee@industrialfire.co.za](mailto:lee@industrialfire.co.za)

**Zarto Williams** Cell: 061 158 6941 or email: [zarto@industrialfire.co.za](mailto:zarto@industrialfire.co.za)



[www.industrialfire.co.za](http://www.industrialfire.co.za)



## SPECIFICATIONS

The GALLANT Heavy HazMat offers the following base specifications (the unit can be adapted to suit specific or bespoke needs)

- 13,500kg GVM chassis cab with 4x2 or 4x4 capability
- For +7500mm bodies, 6x2 or 6x4 dual rear axle chassis
- 2400mm body width
- Crew seating can be arranged in walk-in area
- Available in single or double cab
- All aluminium superstructure manufactured using large dimensional extrusions
- Three (3) large external compartments each with roller shutter doors
- Adjustable shelves
- Roll-out trays
- Full length walk-in area with a 1,900mm head height
- HVAC system for operations in walk-in area
- Electric tail lift for infinite adjustments for moving heavy equipment in or out of the walk-in area
- Auto-eject charging system for all electrical equipment
- Fully homologated
- Raptor painted to protect the interior against scratching and chipping during equipment movement

*Industrial Fire & Hazard Control – The Home of Imagination*

## GALLANT - Heavy HazMat

The GALLANT Heavy HazMat offers a versatile working environment that can accommodate any hazardous materials handling incident. Whether you need space for all the required HazMat equipment or for personnel rehabilitation or even incident command, the GALLANT Heavy Hazmat is right for the job.

The interior can be configured around the client's requirement and customised for any level of response. The modular body design allows for a range of configurations to suit every response requirement.

With the GALLANT Heavy HazMat there is no longer a concern as to where the over-pack drums and decontamination equipment will be stored for ease of access.

Call for specifications or a demo today

*Significantly enhance the firefighting capability and operational efficiency with the inclusion of the GALLANT Heavy HazMat in your firefighting fleet.*

- Special mounting arrangement for hanging Class A suits
- Rub rail all round to protect the superstructure
- Mobile crane, 2000kg payload, for moving heavy equipment
- 16 kW PTO driven generator as an additional power supply
- Distribution panel for all electrical circuits
- Electric extension reels
- Shoreline connections
- Robotic lightmast system
- Emergency lighting system
- Access ladder for roof mounting of equipment
- Rear view camera
- Automotive paint finish with 3-year warranty
- Five (5) year superstructure warranty
- Front mount electric winch
- Heavy duty bull bar
- Array of equipment that can be supplied and mounted in accordance with the client's specification







## SPECIFICATIONS

The HILOAD Fire & Rescue Vehicle offers the following base specifications (the unit can be adapted to suit specific or bespoke needs)

- Toyota Hilux or Land Cruiser
- Single cab or double cab
- 45% increase in load space on a double cab
- 55% increase in load space for a single cab
- 3000kg payload
- Traction on 6 wheels with payload spread between 3 axles
- Complete replacement for OEM 4x4 chassis. No cutting and inserting of axles
- FEA of OEM chassis to understand areas of weakness under enhanced load and select optimal constructions
- Increased material thickness and section heights, 30 to 40% stiffer through its profile compared to OEM
- Centre axle trailing arms located on arches to further enhance strength in a known area of 4x4 weakness
- Heavy duty front and rear suspension mounts, 25mm lift with OEM suspension geometry retained
- 7 Stage E-Coating and powder-coat for 10-Year anti-perforation warranty,
- Chassis number transferred from 4x4 to 6x6 chassis
- Heavy duty replacement axle housings containing OEM or upgraded drive shafts
- Final drive ratio can be changed to improve acceleration
  - Drum brakes replaced with discs to improve rear braking effort to enable EC Reg 13 brake test pass
  - Trailing arm and panhard rod with anti-roll bar for maximum off-road handling & stability in all 3 planes

## Industrial Fire & Hazard Control – The Home of Imagination

## HILOAD Fire & Rescue Vehicle

The HILOAD 6x6 Fire & Rescue Vehicle redefines mobility in the true sense of the word.

The payload, load space, mobility and single rear wheel application of the 6x6 HILOAD is ideally suited to a number of specialist Fire & Rescue applications.

The 6x6 drivetrain offers an enhanced level of off-road mobility for wildland incidents and incidents in remote locations. The additional payload that translates to more water on an RIV is ideal for responses to congested and confined areas which larger vehicles cannot access.

The HILOAD is ideally suited for operation in urban underground and multi-story car parks with height limits. The HILOAD 6x6 offers a considerable leap in the range of RIVs.

Call for specifications or a demo today

**Significantly enhance the firefighting and rescue capability and operational efficiency with the inclusion of the HILOAD Fire & Rescue Vehicle in your firefighting fleet.**

- Roll centres and centre of gravity tuned for safety and driving feel on and off-road
- ABS, ESP and all other traction control and stability systems retained from OEM 4x4
- Handbrake on both axles, hardlines extended to maintain brake fluid pressure
- No transfer box limitation on speed
- All aluminium superstructure manufactured using aluminium extrusions
- Various body designs to suit client requirements
- Large compartments with lockable roller shutter doors
- Raptor coatings provided
- GRP body offered as optional
- Front mounted HyperSight Thermal Imaging camera monitor in-cab
- Electric winch
- Adjustable shelves in compartments
- Rear view camera
- Battery charging system with auto-eject function
- Automotive paint finish with 3-year warranty
- Powerful driving lights
- Pneumatic lightmast system
- Emergency lighting system with flashers
- Heavy duty bull bar
  - Tow bar fitted
  - Recovery shackles provided
  - Service plan
  - Extended warranty program
  - Array of equipment that can be supplied and mounted in accordance with the client's specification



**INDUSTRIALFIRE**  
& HAZARD CONTROL

For further information please reach out to:

**Trevor Fiford** Cell: 082 651 2580 or email: [trevor@industrialfire.co.za](mailto:trevor@industrialfire.co.za)

**Abrie Dempers** Cell: 078 159 4845 or email: [abrie@industrialfire.co.za](mailto:abrie@industrialfire.co.za)

**Lee Marques** Cell: 061 225 2710 or email: [lee@industrialfire.co.za](mailto:lee@industrialfire.co.za)

**Zarto Williams** Cell: 061 158 6941 or email: [zarto@industrialfire.co.za](mailto:zarto@industrialfire.co.za)



**INDUSTRIALFIRE**  
& HAZARD CONTROL



[www.industrialfire.co.za](http://www.industrialfire.co.za)

Proud member of the Advanced Group of Companies



## SPECIFICATIONS

- UNIMOG chassis cab with 4x4 capability
- Available in single or double cab
- 2500 litre polypropylene water tank
- 50 litre Class A or Class B foam tank
- Pump and Roll
- PyroHMA Proseus HyLo PTO Driven System, rear mounted
- 75 l/min @ 100 bar
- 950 l/min @ 10 bar
- Foam system for both pumps (individual)
- Stainless steel plumbing
- All aluminium superstructure manufactured using large dimensional extrusions
- Large through compartment behind the cab with lockable roller shutter doors
- Steps for ease of access to the furthest reaches of the compartments
- Bumper mounted Elkhart BrushHawk remotely operated turret
- Pump engagement and discharge valves controlled from the cab
- Cab protection spray bar
- HyperSight thermal imaging camera, front mount
- Electric foam transfer pump for tank refilling
- Electric winch
- Front spray bar, in-cab controlled

*Industrial Fire &  
Hazard Control  
– The Home of  
Imageneering*

## MAMBA Wildland Interface Pumper

The MAMBA Wildland Interface Pumper is unique in its category as it operates with the highly acclaimed Pyro HyLo system...a PyroUHP pump system with a Darley volume pump, all in the same footprint, driven from a hydraulic system on a single shaft. The MAMBA Wildland Interface Pumper provides the ultimate in “go-anywhere” capability and is a beacon of innovation and versatility in firefighting capability.

The MAMBA is testimony to Industrial Fire’s adage of “Home of Imageneering”. The MAMBA Wildland Interface Pumper sets a new standard for protection against urban/suburban/mining/industrial interface with wildland. The MAMBA ensures that firefighters have the required tool to combat fires efficiently and effectively in their quest to save lives and property.

Call for specifications or a demo today



*Significantly enhance the  
firefighting capability and  
operational efficiency  
with the inclusion of the  
MAMBA Wildland Interface  
Pumper in your firefighting  
fleet.*



- Suction hose compartment with door
- Under truck nozzles, in-cab controlled
- Twin hose reels with 30m x 25mm hose and selectable pistol grip nozzle
- 38mm preconnect attack line
- Adjustable shelf in compartment
- Rear view camera
- Battery charging system
- One (65mm) tank fill inlet
- Automotive paint finish with 3-year warranty
- Five (5) year superstructure warranty
- Emergency lighting system with flashers
- Heavy duty bull bar
- MC Fluid Meters for tank level gauges
- Heavy duty pull out tool boards
- Array of equipment that can be supplied and mounted in accordance with the client’s specification



## SPECIFICATIONS

The HOTSHOT Rapid Intervention Vehicle offers the following base specifications (the unit can be adapted to suit specific or bespoke needs)

- Various chassis available with single or double cab
- 4x4 or 6x6 drive arrangement
- Upgraded front & rear suspension
- Non rip seat covers
- Removable rubber floor mats for ease of cleaning
- FlameBlock fire retardant covering over all under chassis cables and pipes
- 160 l/min compressor provided
- Pump and Roll capability
- UHP pump system
- Diesel engine driven as an alternative to petrol
- 42 l/min @ 100 bar
- ATP foam system
- One electric rewind hose reel with 30m x 19mm ultra high pressure hose
- UHP lance nozzle fitted to the hose reel
- 350/450/650 litre water tank manufactured in polypropylene
- 25/50/75 litre Class A foam tank
- Stainless steel plumbing
- All aluminium superstructure manufactured using aluminium extrusions
  - Large compartments with lockable roller shutter doors

*Industrial Fire &  
Hazard Control  
– The Home of  
Imageneering*

## HOTSHOT Rapid Intervention Vehicle

In the Wildland Interface arena, every second counts in a response. The HOTSHOT Rapid Intervention Vehicle is a true defender against the relentless forces of nature. Designed to be mounted on most 4x4 pick-up chassis cabs, the HOTSHOT can combat fires in remote areas and transverse rugged terrain to get there.

The HOTSHOT plays a pivotal role in safeguarding lives, property, animals and the environment. Only the most effective and efficient fire mitigating equipment is selected for fitment to the HOTSHOT and the unit is engineered to travel off-road to reach inaccessible areas.

However, the HOTSHOT RIV has been engineered to extend beyond wildland intervention and it serves as a vital tool in search-and-rescue operations, medical emergencies and disaster response efforts.



*Significantly enhance the  
firefighting capability and  
operational efficiency  
with the inclusion of the  
HOTSHOT Rapid  
Intervention Vehicle in  
your firefighting fleet.*



- Raptor coatings provided
- Special quick fit brackets for equipment mounting
- Front mounted HyperSight Thermal Imaging camera with monitor in-cab
- Electric winch
- Adjustable shelves in compartments
- Rear view camera
- Battery charging system with auto-eject function
- Automotive paint finish with 3-year warranty
- Powerful driving lights
- Pneumatic lightmast system provided and installed
- Emergency lighting system with flashers
- Heavy duty bull bar
- Tow bar fitted
- Recovery shackles provided
- Service plan
- Extended warranty program
- Array of equipment that can be supplied and mounted in accordance with the client's specification

Call for specifications or a demo today



**INDUSTRIALFIRE**  
& HAZARD CONTROL

For further information please reach out to:

**Trevor Fitorf** Cell: 082 651 2580 or email: trevor@industrialfire.co.za

**Abrie Dempers** Cell: 078 159 4845 or email: abrie@industrialfire.co.za

**Lee Marques** Cell: 061 225 2710 or email: lee@industrialfire.co.za

**Zarto Williams** Cell: 061 158 6941 or email: zarto@industrialfire.co.za



**INDUSTRIALFIRE**  
& HAZARD CONTROL



[www.industrialfire.co.za](http://www.industrialfire.co.za)

Proud member of the Advanced Group of Companies

83



## SPECIFICATIONS

- The BRONTO SKYLIFT Fire & Rescue Aerial Platforms offer the following features
- Units from 28m – 112m
  - Municipal and Industrial firefighting units
  - Can be mounted on a various makes and models of chassis cabs
  - Designed for Firefighters & Rescue Technicians
  - Spacious rescue cage with high safe working load
  - Good up-and-over capability and below ground reach
  - Xtreme outreach and a larger action area with one set-up
  - Compact design and excellent height-to-weight ratio
  - Economical and manoeuvrable, greater access to load restricted roads and bridges
  - Stable rescue ladder
  - User friendly Bronto 5+ control system
  - Breathing air, electrical supply and hydraulics in the cage
  - Remote control for boom movements and water monitor
  - Emergency back-up system
  - Detachable winches
  - Stretcher carrier
  - High voltage detector
  - Ultra sonic collision guard
  - Various working lights and camera options
  - Laser rangefinder
    - Bronto Loadman to measure ground bearing

*Industrial Fire & Hazard Control – The Home of Imagineering*

## BRONTO SKYLIFT ..... Safety Above All

When serving fire fighters, time is of the essence. The Bronto aerial platforms are designed for easy manoeuvring, quick set-up and efficient operation to save the precious minutes.

Our products feature spacious rescue cages with various additional equipment, a large water capacity, efficient foam systems and a reach to meet even the most demanding challenges. Our products are equipped with the easy and precise Bronto+ control system, appreciated by those who work at heights.

Each fire department has unique needs set by the operating environment. When acquiring new equipment, a unique set of technical features can be combined to match. We encourage robust planning to ensure you get the equipment that you want and need. At Bronto Skylift, we offer advanced training in the operation of these versatile units.

Call for specifications or a demo today

*Significantly enhance the firefighting capability and operational efficiency with the inclusion of the BRONTO SKYLIFT in your fire fighting fleet.*



**INDUSTRIALFIRE**  
& HAZARD CONTROL

For further information please reach out to:

- Trevor Fiford** Cell: 082 651 2580 or email: [trevor@industrialfire.co.za](mailto:trevor@industrialfire.co.za)  
**Abrie Dempers** Cell: 078 159 4845 or email: [abrie@industrialfire.co.za](mailto:abrie@industrialfire.co.za)  
**Lee Marques** Cell: 061 225 2710 or email: [lee@industrialfire.co.za](mailto:lee@industrialfire.co.za)  
**Zarto Williams** Cell: 061 158 6941 or email: [zarto@industrialfire.co.za](mailto:zarto@industrialfire.co.za)



**INDUSTRIALFIRE**  
& HAZARD CONTROL



[www.industrialfire.co.za](http://www.industrialfire.co.za)

Proud member of the Advanced Group of Companies



## RATEL Rapid Intervention Vehicle

The RATEL Rapid Intervention Vehicle is unique in its category as it operates with the highly acclaimed PyroUHP Hydrus system. The RATEL RIV is designed for a rapid response to effectively combat fires in their insipient stages.

The PyroUHP Hydrus allows firefighters to operate in the most effective range for fire mitigation whether structural, industrial, aviation or wildland. The RATEL can be engineered to fit on any single or double cab pick-up (6x6, 4x4 or 4x2) and offers a host of options to meet the client's specific demands and requirements.

The RATEL is small and compact and easy to manoeuvre in tight spaces and restricted areas but do not be fooled by its size as it punches way beyond its weight category!

Call for specifications or a demo today



## SPECIFICATIONS

- The RATEL Rapid Intervention Vehicle offers the following base specifications (the unit can be adapted to suit specific or bespoke needs)
- Various chassis available with single or double cab
  - 4x2 or 4x4 or 6x6 drive arrangement
  - Upgraded front & rear suspension
  - Non rip seat covers
  - Removable rubber floor mats for ease of cleaning
  - FlameBlock fire retardant covering over all under chassis cables and pipes
  - 160 l/min compressor provided
  - Pump and Roll capability
  - PyroUHP Hydrus, rear mounted
  - Diesel engine driven
  - 75 l/min @ 100 bar
  - Built in foam system
  - One electric rewind hose reel with 60m x 19mm ultra high pressure hose
  - Elkhart Chief UHP nozzle fitted to the hose reel
  - 350 litre water tank manufactured in polypropylene
  - 25 litre Class A or Class B foam tank
  - Stainless steel plumbing
    - All aluminium superstructure manufactured using aluminium extrusions
      - Large compartments with lockable roller shutter doors

*Industrial Fire &  
Hazard Control  
– The Home of  
Imagineering*

*Significantly enhance the  
firefighting capability and  
operational efficiency  
with the inclusion of the  
RATEL Rapid Intervention  
Vehicle in your firefighting  
fleet.*

- Raptor coatings provided
- Special quick fit brackets for equipment mounting
- Front mounted HyperSight Thermal Imaging camera with monitor in-cab
- Electric winch
- Adjustable shelves in compartments
- Rear view camera
- Battery charging system with auto-eject function
- Automotive paint finish with 3-year warranty
- Powerful driving lights
- Pneumatic lightmast system provided and installed
- Emergency lighting system with flashers
- Heavy duty bull bar
- Tow bar fitted
- Recovery shackles provided
- Service plan
- Extended warranty program
- Array of equipment that can be supplied and mounted in accordance with the client's specification



For further information please reach out to:

**Trevor Fiford** Cell: 082 651 2580 or email: [trevor@industrialfire.co.za](mailto:trevor@industrialfire.co.za)  
**Abrie Dempers** Cell: 078 159 4845 or email: [abrie@industrialfire.co.za](mailto:abrie@industrialfire.co.za)  
**Lee Marques** Cell: 061 225 2710 or email: [lee@industrialfire.co.za](mailto:lee@industrialfire.co.za)  
**Zarto Williams** Cell: 061 158 6941 or email: [zarto@industrialfire.co.za](mailto:zarto@industrialfire.co.za)





## SPECIFICATIONS

The ATTACK Trailers offer the following

- Single or twin axles
- Advanced "Hybrid" nozzle technology
- Hydro-Foam proportioning
- Highly efficient waterways
- User-friendly operations
- Gear operated or tiller bar
- Various trailer styles (drop deck or goose-neck)
- Foam totes for Hydro-Foam operation
- Foam pumps (transfer, balanced pressure, FireDos)
- Foam proportioners and eductors
- Dry chemical storage
- Hydr-Chem capability
- Hose storage
- Hose reels (manual or electric)
- Lighting systems

*Industrial Fire & Hazard Control  
– The Home of  
Imagineering*

## ATTACK Trailers

The Industrial Fire & Hazard Control ATTACK Trailers are built with our client's specific needs in mind. These ATTACK Trailers are mobile firefighting platforms capable of large volume discharges to meet unique and specific mitigation requirements. The ATTACK Trailers provide fire suppression, cooling, personnel protection, toxic gas dispersion and so much more.

The design on the operating platform allows the operator the freedom of smooth, rapid horizontal and vertical movement with a maximum articulation of 360°, making these ATTACK Trailers a superior weapon in fighting large scale industrial fires and mitigating other extremely challenging hazards.

Call for specifications or a demo today

*Significantly enhance the  
firefighting capability and  
operational efficiency  
with the inclusion of the  
ATTACK Trailers in your  
response capability*

- Toolboxes
- High expansion foam generators
- Portable electricity generators
- Cranes
- Flows from 2,800 l/min through 53,000 l/min
- Supplied with JRC's
- Can be supplied with JPMA remote foam supply system
- Monitors can be supplied with auto braking devices
- Extended warranty program
- Array of equipment that can be supplied and mounted in accordance with the client's specification



Before



After



Before



After



Before



After



## Industrial Fire & Hazard Control's RECYCLE Program

The Industrial Fire & Hazard Control RECYCLE Program is designed to instil new life in old and tired fire & rescue vehicles. The ever-rising cost of replacing existing vehicles in the fleet is making it difficult for client's to meet their budgets. The replacement of key components allows for an extended operational lifespan of a vehicle that would otherwise be scrapped. Also, the RECYCLE program allows the vehicle to be customised to meet the changing demands of firefighting vehicles as well as meeting current standards and regulations.

Call for details of the Industrial Fire & Hazard Control RECYCLE Program today



## SPECIFICATIONS

The RECYCLE Program can entail the following

- Remount existing fire fighting or rescue superstructure on a new chassis cab
- Include a crew cab extension on an existing vehicle
- Upgrade/repair/refurbish front & rear suspension
- Supply non rip seat covers
- Supply removable rubber floor mats for ease of cleaning
- FlameBlock fire retardant covering over all under chassis cables and pipes
- Refurbish or replace pump system
- Refurbish & upgrade plumbing
- Replace water and foam tanks with polypropylene tanks if and where required
- Refurbish or replace roller shutter or pan doors
- Include new equipment such as deck guns, bull bars, winch, etc
- Refurbish or supply a new foam system
- Refurbish or supply new hose reels
- Convert existing hose reels to electric rewind
- Supply new hose reel hose and nozzles
- Refurbish complete superstructure
- Refurbish inside of cab with new seats and cab linings, door accessories, etc
- Install SCBA seats if required
  - Upgrade electrical system to Multiplex system
  - Line compartments with Raptor or Multispec paint finish

*Industrial Fire & Hazard Control – The Home of Imagineering*

**Investigate the cost effectiveness of a RECYCLE before purchasing a brand-new fire fighting or rescue vehicle and extend the life span of the existing fleet.**

- Provide adjustable shelves, roll out trays and roll out tool boards
- Supply and fit HyperSight Thermal Imaging camera with monitor in-cab
- Refurbish or supply new pump control panel with gauges and controls
- Upgrade steps and ladders
- Supply rear view camera
- Battery charging system with auto-eject function
- Automotive paint finish with 3-year warranty
- Upgrade driving lights
- Provide pneumatic lightmast system
- Fit new emergency lighting system with flashers
- Overhaul engine & transmission
- Overhaul PTO system with shafts
- New signwriting and stripes
- Service plan
- Extended warranty program
  - Array of equipment that can be supplied and mounted in accordance with the client's specification



For further information please reach out to:

- Trevor Fiford** Cell: 082 651 2580 or email: [trevor@industrialfire.co.za](mailto:trevor@industrialfire.co.za)
- Abrie Dempers** Cell: 078 159 4845 or email: [abrie@industrialfire.co.za](mailto:abrie@industrialfire.co.za)
- Lee Marques** Cell: 061 225 2710 or email: [lee@industrialfire.co.za](mailto:lee@industrialfire.co.za)
- Zarto Williams** Cell: 061 158 6941 or email: [zarto@industrialfire.co.za](mailto:zarto@industrialfire.co.za)



# ADVERTISERS' PROFILES



Aquila Corp (Pty) Ltd is a leading distributor of premium rescue equipment to the fire services, emergency services, disaster management, police and other industries across Africa.

Our extensive ranges of products have been carefully sourced from reputable and trusted manufacturers, both local and international.

Aquila Corp is an authorised dealer in South Africa and further afield in Africa for Holmatro Rescue Equipment.

As an accredited Holmatro Dealer Aquila Corp offers the following:

- Sales and marketing of Holmatro rescue equipment
- Comprehensive training and knowledge transfer on all aspects of hydraulic rescue tool application
- Maintenance and service of Holmatro rescue tools
- Lease and rental of Holmatro hydraulic rescue tools.
- Consulting on all aspects of advanced motor vehicle extrication, new vehicle technology and urban search and rescue techniques using Holmatro Hydraulic Rescue Tools.

With an established reputation for premium service and support, Aquila Corp is well known for matching premium products to specific client applications.

Our business represents some of the most respected brands in the world! The products we supply are both high quality and high performance, and our team is knowledgeable and helpful.

Included in the product range supplied by Aquila Corp are hoses, foam and other related firefighting equipment including Firefly Fire vehicle mounted and portable firefighting pumps.

Aquila Corp has also added to its fold, the design and manufacture of polypropylene bodies for rescue and emergency vehicles, which offers many advantages including weight reduction, corrosion resistance, chemical resistance, durability, strength and cost effectiveness.

#### Contact Aquila Corp (Pty) Ltd:

Unit 18, Aquaplan Business Park, 120 E.P. Malan Street, Pomona, Kempton Park, South Africa

Phone: +27 11 823 1927

Johan Muller Mobile: 082 609 3438

Email: info@aquilacorpsa.co.za

sales@aquilacorpsa.co.za

<https://www.aquilacorpsa.co.za>

<https://www.trtg.co.za>



The Advanced Group of Companies supplies fire protection, fire and hazard control, emergency management, and operational risk management services to the African continent.

Comprised of seven subsidiary companies, the group provides a comprehensive range of products and services to the mining, municipal, commercial, hospitality, aeronautical, marine, petrochemical, oil and gas, and industrial sectors across Africa.

1. Advanced FST (Pty) Ltd
2. Advanced Fire Global
3. Advanced Lubrication Solutions
5. Rural Metro Emergency Management Services (Pty) Ltd
6. IRCA Global (Pty) Ltd
7. Advanced Health Care Services and Systems
8. Medi Response
9. WHIP Fire Projects

#### INDUSTRIAL FIRE & HAZARD CONTROL

Industrial Fire & Hazard Control was founded to provide fire fighting, hazmat and risk mitigation products and services to the petro-chemical, oil and gas industry, amongst others.

Industrial Fire & Hazard Control is also active in the mining and aeronautical industries, and works with refineries, processing plants, oil rigs and EPCs across the continent.

Using only the best products on offer from Williams Fire & Hazard Control, Johnson Controls, and a select number of market leaders, Industrial Fire & Hazard Control offers end-to-end solutions, namely:

- Engineering, manufacturing and product supply.
- Servicing, repair and maintenance.
- Training, consultation and assessments.
- Manufacture and supply of fire, rescue, hazmat, and disaster management vehicles.
- Manufacture of firefighting trailers.
- Firefighting surfactants, including PKW and foam concentrates.
- Firefighting and rescue equipment.
- High-volume pumping and delivery devices.
- Mobile firefighting equipment.
- Vehicle-mounted and portable pumps.
- The latest technology in ultra-high-pressure equipment and applications.

- Refurbishing of all makes and models of fire apparatus.
- Repairs and servicing of fire fighting, rescue, hazmat and disaster management vehicles.
- Outsourcing and renting of fire fighting and rescue vehicles.
- Fleet management.

#### Our services:

- Foam testing.
- Fire incident reporting application assistance.
- Fire investigation.
- Emergency foam supply.
- Firefighting foam training.
- Facility evaluations.
- Risk assessments.
- Risk mitigation.
- Repair and servicing of firefighting and specialised vehicles.

#### Our product range:

- Dry Chemical Powder - PKW.
- Dry Chemical, CO2 and Water/Foam Extinguishers.
- Fire Apparatus Components used by OEM Fire Apparatus Manufacturers.
- Foam Concentrates.
- Foam Proportioning Equipment.
- Hoses.
- Large Volume Water Pumps.
- Hydrants.
- Mobile Fire Fighting Equipment.
- Monitors and Nozzles.
- Portable Extinguishing Systems.
- Storage Tank Protection.
- Valves, Manifolds and Valve Adaptors.
- Industrial Fire Apparatus.
- Portable Pumps.
- Ultra High Pressure Systems.
- Gas Detection Systems.
- Thermal Imaging Systems.

#### Contact Industrial Fire & Hazard Control (Pty) Ltd

Tel: +27 (0)82 651 2580

Email: trevor@industrialfire.co.za

15 Prinsloo Street, Alberton North 1456

<https://www.industrialfire.co.za>



ALCO-Safe (Pty) Ltd is the major supplier of quality electronic Breath Alcohol Detectors and accessories in South Africa with 43 years of experience in manufacturing, distribution and support. The company has over three thousand clients to which tens of thousands of Lion Alcolmeters® have been supplied.

ALCO-Safe (Pty) Ltd also supplies drug detection equipment utilising individual urine and saliva test kits as well as electronic instrumentation which provides an analysis and printout of the presence of up to six different types of drugs within minutes.

#### Awareness presentations/operator training

Internal awareness programmes are offered to management and workforce representatives, highlighting alcohol's many negative effects in the workplace. This effectively addresses issues such as contribution to accidents, injuries, productivity, absenteeism and many other loss areas; testing techniques; legal aspects; bodily alcohol concentration with elapsed time versus consumption; many myths; health problems and other matters.

ALCO-Safe has, over many years, assisted a large number of organisations large and small. This has ranged from the supply of equipment only, to the development of substance abuse programmes and their implementation on a national basis.

#### Contact:

Tel: + 27 (0) 12-343 8114

Rhys Evans Email: [alcosafe@icon.co.za](mailto:alcosafe@icon.co.za)

<https://www.alcoholtesting.co.za>



#### 60 years of compressor history

Starting with high-pressure compressors to refill diving cylinders, as used in recreational and military applications. Eventually, adding fire-fighting compressors for ground use, along with industrial gas compressors for nitrogen, argon, helium and lately hydrogen

Recently, with the increased proliferation of natural-gas vehicles, we have begun to manufacture compressors to refill the CNG cylinders used in such vehicles.

Plantfocus – the SA distributor for Coltri have other agencies specialising in cylinders and oxygen boosters. MPS for boosting oxygen and Vitkovic for cylinders.

#### Contact Coltri South Africa - Plantfocus cc

Mobile: +27 (0)82 449 3576

Email: [sales@coltri.co.za](mailto:sales@coltri.co.za) / [steve@coltri.co.za](mailto:steve@coltri.co.za)

#### Websites

<https://www.coltri.com>

<https://www.coltri.co.za>

<https://www.ntsdiver.com>

<https://www.mpstechnology.it/en>



# Divetek Compressors

Divetek Compressors is a leading provider of high-quality compressors designed specifically for breathing and industrial air applications. Established in 2018, our company has been at the forefront of innovation and excellence in the high pressure compressor industry, catering to the needs of both recreations and commercial diving applications and industry throughout sub-Saharan Africa.

## Mission Statement:

Our mission at Divetek Compressors is to engineer, manufacture, and deliver top-tier compressor solutions that prioritize safety, reliability, and performance.

## Products and Services:

Divetek Compressors specialises in the production of a diverse range of compressors tailored for various industry requirements.

Our product line includes:

- Paramina High-Pressure Air Compressors: Designed to deliver compressed air for refilling cylinders, our compressors are crafted with precision and adhere to industry standards for safety and efficiency.
- Nitrox and Mixed Gas Compressors: Specifically engineered for blending and filling Nitrox and mixed gas cylinders. Our compressor solutions offer solutions for Argon, Nitrogen and Helium.
- Portable and Stationary Solutions: Offering both portable and stationary compressor options, providing flexibility for individuals, dive shops, and commercial diving operations.
- Compressor Accessories and Maintenance Services: Alongside our compressors, we offer a range of accessories and provide comprehensive maintenance services to ensure peak performance and longevity of our products.

## Quality Assurance:

At Divetek Compressors, quality is ingrained in every stage of our operations. Our products undergo rigorous testing procedures to meet stringent industry standards, ensuring reliability, safety, and durability. We continuously invest in research and development to stay ahead in technological advancements, striving to exceed customer expectations.

## Customer Focus:

Customer satisfaction lies at the core of our values. We prioritize understanding our clients' needs and preferences, offering personalized solutions and exceptional customer service. Our commitment to building long-term relationships drives us to provide reliable after-sales support, technical assistance, and training programs for our customers. Divetek Compressors stands as a trusted name in the industry, driven by a passion for innovation, quality, and customer satisfaction. With a commitment to excellence and a focus on safety and reliability, we continue to be the preferred choice for divers, industry and military establishments throughout sub-Saharan Africa.

## Divetek Compressors

Unit 15, Skyview Retail Park, CNR CR Swart and Freda Road, Bromhof, Johannesburg.

Tel: +27 (0)11 791 1095

Email: [sales@divetek.co.za](mailto:sales@divetek.co.za) / [compressors@divetek.co.za](mailto:compressors@divetek.co.za)

<https://www.divetek.co.za> / <https://compressors.divetek.co.za>

# Dräger

## Turning Technology into “Technology for Life”

Dräger manufactures medical and safety technology products. In so doing, we protect, support and save people's lives around the world in hospitals, with fire departments, emergency services, authorities and in mining as well as industry.

Founded in Lübeck in 1889, Dräger has grown into a worldwide, listed enterprise in its fifth generation as a family-run business. Dräger has more than 15 000 employees worldwide and is present in over 190 countries around the globe.

Dräger South Africa (Pty) Ltd is a subsidiary of Drägerwerk AG & Co. KGaA.

Community Investment Holdings, a Broad Based Economic Empowerment group headed up by Dr Anna Mokgokong, was appointed to the board of Directors of Dräger South Africa and is a driving force in our development of Empowerment policies within our greater organization and the communities of South Africa.

Dräger was represented via distributors from the late 1970s.

Dräger South Africa (Pty) Ltd was registered for the 1st time as legal entity in 1983.

## Our Reach

Dräger South Africa (Pty) Ltd represents Drägerwerk AG & Co. KGaA in the Southern and Sub-Sahara African region.

Dräger South Africa's Head Office is located in Johannesburg and local branches established in Cape Town and Durban. Also working through agents in East and Sub-Sahara Africa to ensure a close relationship and providing personal service to our clients.

## Our Product Portfolio

Dräger South Africa (Pty) Ltd supplies and services a complete diverse range of medical and safety products to private and public Hospitals, government departments (Fire Services, Chemical Industries, Oil & Gas, Mining and ADM), the general and mining industry, including a full range of respiratory protection and gas warning devices.

All our products benefit from the long years of experience and high level of technical knowledge Dräger has gained in the market place.

## Products supplied and supported in the Medical market include:

- Anaesthesia
- Ventilation
- Thermoregulation & Neonatal Care
- Infrastructure & Projects (Pendants & Theatre Lights)
- Monitoring and Information Technology
- Complementary Products and Accessories
- Dräger Services
- Gas Management Systems
- ALVO Theatre Tables

## Products supplied and supported in the Safety market include:

- Portable and fixed equipment for gas detection, measurement and analysis

- Respiratory breathing systems, ranging from escape units to long duration breathing apparatus.
- Breathing air filters, masks and airline systems.
- Breath: alcohol detection devices.
- Saliva: drug detection devices.
- Chemical protection suits.
- Decompression chambers and diving systems.
- Fire Fighting Equipment and Apparel.
- Specialized local Engineered Solutions.

## Customer Service Focus

Customer Service and feedback is of the utmost importance at Dräger.

This aspect of our total operation is under continual review to ensure the customer receives maximum attention at all times and in all areas of requirements.

## Education and Training

We have established an Authorized Education and Training Centre for the Southern Africa region, based out of our head offices in Johannesburg.

Our trainers are certified from the parent company to provide application training on all Dräger products.

With our focus on innovation means our staff keeps abreast with the latest technology products and systems

## Branches in South Africa

*Dräger Head Office – Johannesburg*

Beatty Street, Waterfall Commercial District Buccleuch Sandton

Tel: +27 11 059-4200 Fax: +27 11 465 6953

*Dräger Cape Town*

Unit no. 2, 7 On London, Brackengate Business Park

Tel: +27 21 819-3000 Fax: +27 21 552-6713

*Dräger Durban*

17 Thynk Industrial Park, Cnr BrinckworksWay & Queen Nandi Drive Briardene, Durban North

Tel: +27 31 812 7900 Fax: +27 31 563-6847

*Dräger Bloemfontein*

PO Box 100829, Brandhof, 9324

Tel: +27 83 632 1027

*Dräger Safety Zenith (Pty) Ltd*

Mercury Road, Woodbrook East London

Tel: +27 43 731 1263

Visit us on the web – [https://www.draeger.com/en\\_za/home](https://www.draeger.com/en_za/home)



Firebreak SA (PTY) LTD, a BBBEE Company was founded in 1996 to provide quality products and great service which exceeds the customers expectations.

Our knowledgeable sales staff have a combined 100 years of experience within the Fire and Safety Industry. Firebreak is in business to provide a total package of Safety Fire & Rescue solutions.

Their product range encompasses a wide range of products such as permanent and portable breath testers; gas detection equipment; chemical suits; fall arrest devices; confined space escape products and much more.

Firebreak SA provide training and full service back up to this range of equipment:-

- Scott Agent (SCBA's) / 3M Products
- RKI Portable + Fixed Gas Detectors
- LIFELOC Portable and Permanent Breath Testers
- DuPont range of chemical suits
- TFT / Vanguard Fire Fighting Products
- Bullard / Viking Fire Protective Equipment
- LYMAE Advanced Fire Protective suits & coveralls
- KARAM Fall Arrest / Height Safety Solutions
- Darley (ex-USA) fire tools (Hooligan Tools/ Axes / Pike Poles)
- Fire Servicing / Inspections / Detection systems (SABS Accredited)

## Contact Firebreak SA (PTY) LTD ...

EVERYTHING YOU NEED FOR FIRE, SAFETY & RESCUE

Offering exceptionally fast service backed up by “staff steeped in experience” ... willing to help you solve your every problem.

Tel no: +27 (0)11 908 6960

<https://www.firebreaksa.co.za>

## Team Members:

Duane Basson: +27 (0)82 253 6885 /  
Email: [duane@firebreaksa.co.za](mailto:duane@firebreaksa.co.za)

Paddy Mallett: +27 (0)63 692 5304 /  
Email: [paddy@firebreaksa.co.za](mailto:paddy@firebreaksa.co.za)

Ramesh Jeram: +27 (0)82 880 2723 /  
Email: [ramesh@firebreaksa.co.za](mailto:ramesh@firebreaksa.co.za)

Josh Mahlangu: +27 (0)72 126 9459 /  
Email: [josh@firebreaksa.co.za](mailto:josh@firebreaksa.co.za)

Vanessa Peens: +27 (0)83 225 6659 /  
Email: [vanessa@firebreaksa.co.za](mailto:vanessa@firebreaksa.co.za)

Donovan van der Schyf: +27 (0) 82 574 0782 /  
Email: [donovan@firebreaksa.co.za](mailto:donovan@firebreaksa.co.za)

Malebo Kgamede: +27 (0) 64 987 0820 /  
Email: [malebo@firebreaksa.co.za](mailto:malebo@firebreaksa.co.za)

Blane De Meillon: +27 (0)79 493 7958 /  
Email: [blane@firebreaksa.co.za](mailto:blane@firebreaksa.co.za)

## Granite Designs **EMBROIDERY**

We are a BBE Level 1 company based in Johannesburg specialising in embroidery on corporate t-shirts, caps, and other clothing. We embroider fire department insignia on t-shirts, station wear, t-shirts for sports days and promotional items.

### Contact June at Granite Designs

Cell: +27 (0)66 312 6505

Email: junestjohn06@yahoo.com



Dates: 23-24 July 2024

(See **Safety First Association**)

For further information contact Debbie - +27 (0) 83 266 6662

Email: debbie@safety1st.co.za

<https://www.safety1st.co.za/events/>



For more than half a century, Holmatro has been developing, producing, selling and servicing high-pressure hydraulic rescue equipment for Fire and Rescue Organisations.

Based on the needs of end users and manufactured at two state-of-the-art production plants in the Netherlands and the USA, Holmatro products are known for their high quality and innovative technology.

Holmatro rescue tools are sold and serviced all over the world through offices in various countries and a comprehensive dealer network.

When it comes to rescue equipment, Holmatro's highly experienced engineers translate innovative ideas into smaller, lighter and more powerful tools for the Fire and Rescue Service.

The result is a full range of high-quality rescue equipment enabling you to work efficiently under pressure. Holmatro tools are designed to help you to save lives quicker, easier and safer.

Excellence in performance, innovation and quality are the three pillars of the Holmatro organisation.

They are the reason why our products last for years and why Holmatro is the brand of choice for rescue professionals throughout the world.

Once you start using Holmatro tools, you will use them for life!

### Contact Aquila Corp (Pty) Ltd:

Unit 18, Aquaplan Business Park, 120 E.P. Malan Street, Pomona, Kempton Park, South Africa

Phone: +27 11 823 2481

Johan Miller Mobile: 082 609 3438

info@aquilacorp.co.za / sales@aquilacorp.co.za

<https://www.aquilacorp.co.za>

<https://www.trtg.co.za>



Lymae has been supplying Protective Clothing, helmets, and accessories for the past 30+ years.

Only the latest and most effective materials and technologies available, certified by the US National Fire Protection Association NFPA 1971 and EN469, are used to manufacture protective clothing which are housed in our own building Southeast of Pretoria.

### Our mission

We at Lymae stand in awe of those brave men and woman who, at risk of their lives and well-being are prepared to go to the aid of their fellow people in time of dire physical need.

Our mission is to provide them with the best protective wear and gear in the world - without compromise.

Only the latest and most effective materials and technologies available, certified by the (US) National Fire Protection Association (NFPA), are used.

For us, their safety will always be of paramount concern.

### Our manufacturing facility is located at:

Physical address: 81 Sovereign Drive; Route 21 Corporate Park; Irene

### Contact Lymae

Tel: +27(12) 345-5885

Email: [lymae@mweb.co.za](mailto:lymae@mweb.co.za) / [sales@lymae.co.za](mailto:sales@lymae.co.za)

<https://www.lymae.co.za>



### MARCÉ – PRODUCTS THAT SAVE LIVES

What does this mean for Marcé as a Company? When selecting a Service Provider to build you a fire truck or supply you with specialised fire equipment that will be used to save lives, one has to ask the question; Who will respond and understand my needs and supply me with the best possible solution available in the market?

There are several manufacturers and suppliers who build fire trucks and supply specialised fire equipment and then there is Marcé. Marcé always comes up with innovative ideas, engineering solutions and new product developments to enhance operational capability in the Emergency Services.

Marcé has achieved several engineering feats over the past few years that saw our company grow from a small manufacturer to a Global player in the world market. Some of our innovations and achievements, to name a few, include:

- Development of our own range of 4x4, 6x6 and 8x8 Airport Fire Fighting Vehicles (ARFF) with a local content exceeding 60%
- Development of our own range of electronically controlled roof and bumper turrets
- Development of a vehicle simulator as part of the supply contract on our Rhino Range of Airport Fire Fighting Vehicles
- Development and manufacturing of local crew cabins for both ARFF and normal fire truck applications
- Our own advanced range of SCBA equipment
- Our own range of Firefighting Nozzles and Hoses
- Building a one-of-a-kind Custom Industrial pumper that uses a water filtration system at a flow of 14 000 litres per minute
- Development of our own software for command and control, asset & fleet management as well as electronic vehicle and pump management systems.

Marcé is committed more than ever to South African job creation and strives to constantly increase local content in all our products, whilst also having an ever-expanding international footprint.

We not only manufacture fire fighting vehicles in our manufacturing plant in Centurion but also in our Cape Town plant, with our Polokwane plant handling all our branding requirements apart from also being a fully-fledged service centre.

Marcé is very proud to have a family Nationally and Internationally that we call our clients. In the trying times we are in; we are committed more than ever to take the Emergency Services fraternity forward with more quality products and innovations.

Each enquiry motivates our sales team to leave no stone unturned in finding the right product to ensure the best value for money and maintain the highest standards that Emergency Services deserve.

### Simply put – MARCÉ EXISTS TO SAVE LIVES

#### Contact Marcé Fire Fighting Technology (Pty) Ltd

1012 Ergon Road, Lyttelton, RSA

P O Box 8361, Centurion, 0046 RSA

Tel: + 27 (0)12 742 9200

Fax: + 27 (0)12 742 9299

E-Mail: [sales@marce.co.za](mailto:sales@marce.co.za)

Website: <https://www.marce.co.za>



In 1999 a group of South African volunteers went to assist after an earthquake in Izmit, Turkey. Seeing a serious search and rescue skills shortage in Southern Africa, in 2001 NGO/NPO Specialised Rescue South Africa (Rescue South Africa) was formed.

The vision was to show the world that Africans can help themselves, offering humanitarian services worldwide, can be good citizens of the world, while at the same time building capacity in the SADC region.

### Response

Rescue South Africa has proudly responded to the following sudden onset disasters:

- 2001 Earthquake – Gujarat, India
- 2002 Volcanic Eruption – Goma, DRC
- 2003 Earthquake – Algeria
- 2003 Earthquake – Iran
- 2005 Earthquake – Pakistan
- 2010 Earthquake – Haiti
- 2011 Earthquake & Tsunami – Japan
- 2013 Typhoon Haiyan – Philippines
- 2015 Floods – Malawi
- 2019 Cyclone Idai – Beira, Mozambique
- 2019 Cyclone Kenneth – Pemba, Mozambique
- 2021 Cyclone Eloise – White River
- 2022 KZN Floods – Durban
- 2023 Cyclone Freddy – Malawi

### Expectation

Rescue South Africa has four primary objectives:

1. To respond to sudden onset disasters providing technical rescue skills – regionally, nationally & internationally
2. To build a cache of equipment for training and response (now +60 tonnes)
3. To build capacity by offering high quality rescue training regionally, nationally & internationally
4. To facilitate outreach programmes aimed towards disadvantaged & vulnerable communities.

### Capacity

RSA is fully equipped and able to respond to the following incident types:

- High Angle Rescue
- Fire Search & Rescue
- Motor Vehicle Rescue

- Confined Space Rescue
- Trench Rescue
- Swift Water and Flood Rescue
- Hazmat Awareness & Operations Rescue
- Industrial & Agricultural Rescue
- Wilderness Search & Rescue
- Structural Collapse
- Mass Transit Accidents
- Aviation Rescue

#### Training

We offer top quality rescue training courses to emergency service personnel as well as various mines on the continent.

Our curriculum of courses is modular and include the University of Johannesburg accredited Advanced Rescue Practitioner (USAR) qualification:

#### BASIC RESCUE PRACTITIONER

- High Angle 1 Rescue – 10 days
- Fire Search and Rescue – 5 days
- Motor Vehicle Rescue – 10 days
- Industrial and Agricultural – 5 days

#### BRIDGING COURSE

- High Angle 2 Rescue – 10 days

#### WILDERNESS SEARCH AND RESCUE PRACTITIONER

- Aquatic Surface Rescue (Swift Water and Small Boat Handling) – 10 days
- Aviation Rescue – 5 days
- Wilderness Search and Rescue – 10 days

#### URBAN SEARCH AND RESCUE PRACTITIONER

- Hazardous Materials Rescue – 5 days
- Confined Space Rescue – 5 days
- Trench Rescue – 10 days
- Structural Collapse Rescue – 10 days

In order to qualify for the USAR courses, delegates should be young, fit and intelligent with the following:

- Matric or Grade 12 equivalent
- Basic patient care certificate
- Valid Identity document or passport

#### Contact Rescue South Africa

Ian Scher – Chief Executive Officer

PO Box 500, Saxonwold, 2132, Gauteng, South Africa

Mobile: +27 (0)82 459 9765

Email: [ian@rescue-sa.co.za](mailto:ian@rescue-sa.co.za)

<https://www.rescue-sa.co.za>



Rural Metro Emergency Management Services (PTY) Ltd® is B-BBEE compliant. Established in October 2000, we are a fully independent organisation specialising in fire brigade services, training and disaster management. The company comprises full-time certified professionals with considerable experience in these disciplines.

Rural Metro Emergency Management Services (PTY) Ltd® was founded on the premise that communities and industries in Africa could benefit from innovative and cost effective ways of delivering fire and emergency services as well as managing personnel and resources. Pursuing prevention is a key strategy that contributes to our success.

Aware of the evolving fire and emergency needs of our customers, we have developed satisfying customer relations based on mutual trust and quality of our services. The energy, dedication and genuine care of our staff is the backbone of our company.

#### Accredited Training Academy

Rural Metro's Internationally Accredited Academy offers training in a range of subjects relative to firefighting, disaster management and occupational health and safety. Training programs are National Fire Protection Association (NFPA) aligned.

Competent Learners achieve certification via IFSAC, SAESI or LGSETA.

Rural Metro's course facilitators are registered NFPA 1041 instructors. In addition, Rural Metro has accredited assessors, moderators and verifiers.

#### Professional services provided:

Rural Metro Emergency Management Services (PTY) Ltd® assists government, industry, commerce and all role players reduce the incidents and impacts of fire, injury and occupational safety hazards through the provision of:

- Education and awareness
- Approved training courses
- e-Learning
- Disaster management
- Risk and hazard assessment
- Fire Engineering and consulting services
- Outsourced fire, rescue and hazmat services
- Communications
- Fire equipment supplies

#### Contact Rural Metro Emergency Management Services (PTY) Ltd®

Telephone: +27 (0)33 345 0080 | Fax: +27 (0)33 345 2900

Email: [headoffice@ruralmetrosa.com](mailto:headoffice@ruralmetrosa.com)

298 Burger Street, Pietermaritzburg, KwaZulu-Natal, South Africa, 3201

Suite 23 Postnet, Private Bag X9118, Pietermaritzburg, KwaZulu-Natal, South Africa, 3200

<https://www.ruralmetrosa.com>



Sysman is a seasoned veteran within the South African Emergency and Disaster Management markets, boasting 42 years of dedicated service.

Our suite of offerings underscores a comprehensive approach to emergency response, marrying cutting-edge technology with extensive field experience.

The core of Sysman's software product line is our latest ESS Call Taking & Dispatching system, which exemplifies a state-of-the-art emergency management tool.

It not only facilitates rapid call taking and dispatching but also integrates advanced GIS capabilities for precise location tracking, all presented through a user-friendly interface.

The launch of our new ruggedised Remote Dispatch Consoles (RDCs) includes client-specific software with real-time video streaming from incident scenes, incident management tools, and other features. This represents Sysman's commitment to leveraging advanced technology for enhanced situational awareness.

Sysman has also launched its latest software platform, ESS-DIMS. Specifically designed to streamline the complexity of managing large-scale emergencies it offers a comprehensive suite of tools that facilitate efficient planning, real-time coordination, and effective response strategies.

ESS-DIMS integrates seamlessly with our ESS Call Taking & Dispatch platform, providing a unified command and control interface that enhances situational awareness, communication, and decision-making capabilities. With features like dynamic resource allocation, incident simulation, and robust communication channels, ESS-DIMS ensures that emergency management teams can swiftly adapt to evolving situations, making it an indispensable tool for provinces, metropolitan areas, cities, and local municipalities aiming to bolster their resilience during major incidents and disasters.

Its deployment could very well set a new standard in disaster preparedness and response, offering a glimpse into the future of Emergency Management where technology empowers quicker, more informed decisions in critical moments.

Our portfolio further extends to Vehicle and Fleet Management solutions, in addition to non-emergency Service Call Management systems also. This demonstrates our holistic view of services that Government entities are required to deliver.

With a strong presence in South Africa and beyond, we stand as a long-term, reliable partner for enhancing Emergency & Disaster Management service delivery within your jurisdiction.

#### Contact Sysman

Tel: +27 (11) 300 3300 or 0861 SYSMAN

Email: [sales@sysman.co.za](mailto:sales@sysman.co.za)

<https://www.sysman.co.za>



Vanguard Fire & Safety are Africa's leading distributors of specialised Fire and Safety Protection Equipment and Apparel. Founded over 30 years ago, we have a longstanding track record of supplying premium quality branded products that meet the highest international occupational health and safety standards in the Fire-fighting, Emergency Services and Industrial Safety segment.

With a focus on high quality, most of our products are approved to internationally recognised standards at competitive prices, and we provide an effective after-sales back-up service.

Our leading brands for the emergency services that we are exclusive dealers for are:

- Task Force Tips (Monitors, branches and related water delivery equipment)
- Bullard (Fire helmets & Thermal imaging cameras)
- Harvik/Viking (Fire boots)
- Lifeliners (Flash Hoods)
- SuperVac (Positive pressure ventilators)
- Eschbach (Type III Fire Hose)
- Sava (Rescue & Hazmat equipment)
- TSI (Water pressure & flow meters)
- Underwater Kinetics (Personal lighting equipment)

Our leading brands for the safety industry

- MCR Safety Crews safety glasses
- MCR Safety Memphis gloves
- Ultitec Protective Coveralls

Our established distribution footprint in the petro-chemical, mining, construction, defence, and fire-fighting industries in the SADIC region has positioned us as a leader in the Protective Clothing, Safety and Fire-fighting Equipment sector.

Find out more about our expert fire and safety equipment and apparel on

Website: <https://www.vanguardfire.co.za>

or call us on + (0) 31564-3200



**QUO VADIS: FUTURE OF FIRE SAFETY AND THE EMERGENCY SERVICES - INNOVATIONS AND SOLUTIONS**

**Dates: 23-24 July 2024 - Organiser: Safety First Association**

For further information contact Debbie - +27 (0) 83 266 6662

Email: [debbie@safety1st.co.za](mailto:debbie@safety1st.co.za)

**BOOK NOW!** <https://www.safety1st.co.za/events/>







# Southern African Emergency Services Institute NPC

Where we come from and where we are now...

## History and introduction

Years ago, the fire services relied on volunteers without proper skill and training to work as firemen. It was not until the founding of the South African Fire Service Institute, that the authorities saw it necessary to have a qualified workforce as it proved that the trade was demanding.

In Great Britain, an organisation established in 1918, was the first serious effort by the firefighting services of the British Empire to encourage firemen to obtain a recognised technical qualification. Up to 1930, efforts to educate firemen were met with limited response. Even though papers were set and marked in Britain, there were language barrier issues with firemen who were not fluent in English. For this reason, and shortage of text books, few firemen obtained qualifications.

With the inception of the South African Fire Services Institute (now SAESI), in 1959, many things changed and advanced. For the first time in South African history of firefighting, the South African firemen could qualify for a diploma in fire engineering by passing the examination of the Institute of Fire Engineers.

Establishing the Institute itself was not so easy; in fact, there had been several attempts to form a body that would be solely responsible for regulating the fire services in the country. A number of South Africans were affiliated to the British Fire Services Association, which was formed in 1949 after a merger between the Professional Fire Brigade Association and National Fire Brigades (representing volunteers belonging to industrial services). This body and those that were established in earlier years operated for 60 years aiming to standardise equipment, training and rank structures and also getting subsidies from central governments. All these plans were successful, but later the merger of British Fire Services had concentrated mainly on their own domestic affairs.

In January 1959, Chief Fire Officers LI Terre-Blanche of Brakpan, ESC Barber of Nigel and JJ Pretorius of Pretoria who collectively formed members of the Transvaal Branch of the Institute, met to discuss the advantages of being members of the British Fire Services and the Commonwealth and Overseas Fire Services Association. This discussion encouraged ideas of establishing something similar in South Africa.

Given the rich political background of this country it comes as no surprise that this proposal was strongly opposed by some quarters that had political motives to what they saw as an attempt to trespass on the prerogative of the British and Commonwealth organisations. This would prove to be a struggle throughout the existence and advances SAESI made over the years. Nonetheless a month later nine candidates representing the Transvaal Fire Department met in Nigel fire station recreational hall to further discuss development strategies. This then led to the official formation of the South African Fire Services Institute on March, 02 1959.

This meant that all fire departments in the country were circularised with each department's representative in the



Institute. In 1960 the first examinations for the Graduate and Associate Diplomas of the South African Fire Services Institute along with the examination for what since have become the junior and senior firemen certificates, were held in centres throughout the country. These initial qualifications expanded to Preliminary Certificate, Certificate, and later Higher Certificate in Fire Technology as well as Diploma and Higher Diploma in Fire Technology. From these initial qualifications the National Diploma in Fire Technology was developed that was offered by the Technicons.

SAESI investigated skill specific training internationally and looked at American based skills programs for the entry level firefighter. It was decided to obtain accreditation from the International Fire Services Accreditation Congress (IFSAC) in 1995. SAESI received accreditation for 4 NFPA Codes (6 programmes).

Among other responsibilities of the Institute, it was decided that SAESI would operate as the official mouth piece of the firefighting services. This would lead to many advances of the Institute in the future.

**Our Vision** - SAESI, a professional emergency services organisation, dedicated to the protection of life, property and the environment.

**Our Mission** - To constitute as a member driven professional organisation, to promote safety of the community and aspiration of its members through the promotion of all aspects of emergency services.

Since the establishment of the Southern African Emergency Services Institute in 1959 the upliftment, development and recognition of the Fire Fighter and Emergency Responder has remained at the heart of its business. Introducing South African Fire Fighter Qualifications at the onset, expanded with International Standards for the industry and fraternity being implemented as the bench mark for qualifications and best practice. SAESI's innovation led to many others following suit and the evolution of the Institute itself to a recognised Professional Body by the South African Qualifications Authority cementing our vision and mission.

## SAESI's progress in the modern environment

Whilst competition is a reality of any organisation irrespective of its product and or status such as Non-profit versus for Profit, staying relevant, ahead of the pack and successfully ensuring business continuity is at the core of measuring 'success'. Given the fact that SAESI is celebrating 64 years of existence could easily make one say, we made it. However, given the fact that during these 64 years not only were we faced with several Government changes,

Laws and Regulations that impacted the firefighting industry significantly but also new legislations on training and education, had to be contemplated. Being able to re-invent yourself and take on 'chameleon' adaptability in an ever changing commercial, competitive and customer demand environment is

no small feat. Not only does this ability and longevity set us apart but have established the standard for employment, qualifications and recognition that became the benchmark and example many that came after and are entering the arena is using as example.

One of the biggest challenges that come with the freedom of South Africa and its Political Democracy, was that we were compared with the International Standards and our International Equivalency was being exposed. The benefit of SAESI having had such exposure and one of the reasons for its establishment under Britain Commonwealth rules, made it easier to adapt. Unfortunately, current education and qualifications landscape are polarised towards an academic preference.

Firefighting is very skill specific and hands-on at the start of the firefighter career path. Political influences post 1994 that favours qualifications on the National Qualifications Framework irrespective of its application and relevance on the world of work versus Skills programmes, Recognition of Prior Learning and Experiential Learning as deemed to be fit for purpose to the fire services remain our biggest challenge to be recognised and accepted as a qualified fire professional.

## Fire fighter pride

SAESI and the fire fraternity in South Africa is a very unique collective. There is none other and we definitely cannot be compared. However, one thing that binds us all and that is evident to any individual or entity we engage with is our passion for the industry and what we do. This manifests in many ways, even in memorabilia that you would most probably find in each and every firefighter home, office or even on his person. Call it pride if you will, but it's actually family. No matter your age, culture, gender, education or where you come from, if you made it and you get to wear the uniform, you are family. Hearing a fire engine on your day off, immediately sparks interest, concern and pride, knowing that its 'us' going into the danger, when the rest is running from it. Being in the privileged position to not only educate the skills required to do this dangerous but necessary job, but more so equipping and shaping the industry and individual firefighter into such a collective of experts and professionals is indeed an honour.

Similarly, our status as Certifying entity that certifies Internationally recognised and sought-after qualifications will continue to not only equip the South African firefighter with the required qualifications and skill sets, but will continue to make them internationally marketable and sought after. In other words, continuing in expanding and affirming our relevance in the industry through new recognitions and developments for the fire and emergency responder aligned to trends and changes in the whole landscape of training, technology, equipment, employment will continue to be our focus.

## MOA with SALGA

Evidence of this characteristic of SAESI is the fact that after many years of engagements and collaborative talks with the South African Local Government Association, SALGA, we signed a Memorandum of Agreement with them that will have significant advantages for the fire and emergency responder and SAESI member. The South African Local Government Association is an autonomous association of all 257 South

African local governments, comprising of a national association, with one national office and nine provincial offices. SALGA has a clear strategic role to play in representing the interests of local government within the system of government as a whole and supporting its members to fulfil their developmental obligations, on the other.

## Milestones

Due to the long and rich history of the Southern African Emergency Services Institute it is difficult to give a brief yet justified overview of the Institute. However, several milestones cannot be ignored; SAESI was the first organisation to establish South African Qualification for South African requirements in the fire industry, SAESI was the first organisation to bring International Recognised Skills programs and Qualifications to South Africa in the form of the NFPA Standards and IFSAC Certification, SAESI evolved from a constitutional organisation to a registered Non-Profit Company in 2014, SAESI became the only recognised Professional Body for the fire and emergency services in South Africa to be recognised by the South African Qualifications Authority, SAESI established the benchmark upon which current qualifications from Academic Institutions and Occupational Qualifications are derived from.

2023 is a very significant year for SAESI. Not only was the first female President elected, our first all-female Presidency was elected, and both our re-recognition and re-accreditation as Professional Body for the Fire and Emergency Services, and our re-accreditation site visit as a Certifying Entity for the International Fire Services Accreditation Congress (IFSAC) took place this year.

We are proud to confirm that we have been awarded re-recognition as a Professional Body for SAQA and re-registration of SAESI's Professional Designation Firefighter Practitioner (SA) FFP (SA).

The IFSAC site visit looks very promising. SAESI is currently registered to certify 80 programmes from 13 NFPA Standards that is accredited with the International Fire Services Accreditation Congress (IFSAC). SAESI has 25 Accredited Training Providers that train on a variety of these programmes in South Africa.

## Best Emergency Services Training Provider 2023 - South Africa

As a close-knit community of individuals relying on their brilliance to safeguard the lives of people in danger, the team behind SAESI has served as a reminder that nothing is impossible. It's proven what can happen if you stick to your goals and pursue them, no matter the opposition. SAESI's story is a tale of overcoming trials and tribulations for the betterment of the industry it desperately seeks to serve, and how no feat should be considered impossible. Now, SAESI is a globally recognised, award-winning collective that's continuously promoting excellence at every turn, and we're beyond proud to be a part of its journey.

## Further reading about this prestigious award:

Education and Training Awards - Corporate Vision Magazine (corporationvision-news.com)

Education and Training Awards 2023 (corporationvision-news.com)

# SAESI/IFSAC NFPA Accredited Levels

| NFPA Standard and Edition                   | Level  |
|---|--|
| NFPA 470, 2022<br>(Previously 472 and 1072) | Hazardous Materials / Weapons of Mass Destruction Awareness Level - Chapter 5<br>Hazardous Materials / Weapons of Mass Destruction Operations-Core Level - Chapter 7<br>Hazardous Materials / Weapons of Mass Destruction Operations Level-Mission Specific Competencies: Personal Protective Equipment - Chapter 9.2<br>Hazardous Materials / Weapons of Mass Destruction Operations Level-Mission Specific Competencies: Mass Decontamination - Chapter 9.3<br>Hazardous Materials / Weapons of Mass Destruction Operations Level-Mission Specific Competencies: Technical Decontamination - Chapter 9.4<br>Hazardous Materials / Weapons of Mass Destruction Operations Level-Mission Specific Competencies: Evidence Preservation & Public Safety Sampling - Chapter 9.5<br>Hazardous Materials / Weapons of Mass Destruction Operations Level-Mission Specific Competencies: Product Control - Chapter 9.6<br>Hazardous Materials / Weapons of Mass Destruction Operations Level-Mission Specific Competencies: Detection, Monitoring & Sampling - Chapter 9.7<br>Hazardous Materials / Weapons of Mass Destruction Operations Level-Mission Specific Competencies: Victim Rescue & Recovery - Chapter 9.8<br>Hazardous Materials / Weapons of Mass Destruction Operations Level-Mission Specific Competencies: Response to Illicit Laboratory Incidents - Chapter 9.9<br>Hazardous Materials / Weapons of Mass Destruction Technician Level - Chapter 11 |
| NFPA 1001, 2019                             | Fire Fighter 1 - Chapter 4<br>Fire Fighter 2 - Chapter 5   |
| NFPA 1002, 2017                             | Driver/Operator General Requirements - Chapter 4<br>Driver/Operator Fire Pump - Chapter 5<br>Driver/Operator Aerial Device - Chapter 6<br>Driver/Operator Wildland Fire Apparatus - Chapter 8<br>Driver/Operator Aircraft Rescue & Fire-Fighting Apparatus - Chapter 9<br>Driver/Operator Mobile Water Supply - Chapter 10   |
| NFPA 1003, 2019                             | Airport Fire Fighter - Chapter 4   |
| NFPA 1006, 2021                             | Rope Rescue Awareness - Chapter 5.1<br>Rope Rescue Operations - Chapter 5.2<br>Rope Rescue Technician - Chapter 5.3<br>Structural Collapse Awareness - Chapter 6.1<br>Structural Collapse Operations - Chapter 6.2<br>Structural Collapse Technician - Chapter 6.3<br>Confined Space Rescue Awareness - Chapter 7.1<br>Confined Space Rescue Operations - Chapter 7.2<br>Confined Space Rescue Technician - Chapter 7.3<br>Common Passenger Vehicle Rescue Awareness - Chapter 8.1<br>Common Passenger Vehicle Rescue Operations - Chapter 8.2<br>Common Passenger Vehicle Rescue Technician - Chapter 8.3<br>Heavy Vehicle Rescue Awareness - Chapter 9.1<br>Heavy Vehicle Rescue Operations - Chapter 9.2<br>Heavy Vehicle Rescue Technician - Chapter 9.3<br>Wilderness Search & Rescue Awareness - Chapter 11.1<br>Wilderness Search & Rescue Operations - Chapter 11.2<br>Wilderness Search & Rescue Technician - Chapter 11.3  |

Trench Rescue Awareness - Chapter 12.1  
Trench Rescue Operations - Chapter 12.2  
Trench Rescue Technician - Chapter 12.3  
Machinery Rescue Awareness - Chapter 13.1  
Machinery Rescue Operations - Chapter 13.2  
Machinery Rescue Technician - Chapter 13.3  
Swiftwater Rescue Awareness - Chapter 18.1  
Swiftwater Rescue Operations - Chapter 18.2  
Swiftwater Rescue Technician - Chapter 18.3

|                                      |  |
|--------------------------------------|--|
| NFPA 1021, 2020                      | Fire Officer 1 - Chapter 4<br>Fire Officer 2 - Chapter 5   |
| NFPA 1026, 2018                      | Incident Commander - Chapter 4<br>Safety Officer - Chapter 5<br>Public Information Officer - Chapter 6<br>Liaison Officer - Chapter 7<br>Operations Section Chief - Chapter 8<br>Operations Division/Group Supervisor - Chapter 11<br>Strike Team/Task Force Leader - Chapter 12<br>Air Tactic Group Supervisor - Chapter 15<br>Planning Section Chief - Chapter 16<br>Rescources Unit Leader - Chapter 17<br>Situation Unit Leader - Chapter 18<br>Logistics Section Chief - Chapter 21 |
| NFPA 1031, 2014                      | Fire Inspector 1 - Chapter 4<br>Fire Inspector 2 - Chapter 5<br>Fire Inspector 3 - Chapter 6<br>Plan Examiner 1 - Chapter 7<br>Plan Examiner 2 - Chapter 8   |
| NFPA 1033, 2014                      | Fire Investigator - Chapter 4  |
| NFPA 1035                            | Fire & Life Safety Educator 1 - Chapter 4<br>Fire & Life Safety Educator 2 - Chapter 5<br>Public Information Officer - Chapter 7   |
| NFPA 1041, 2019                      | Fire & Emergency Services Instructor 1 - Chapter 4<br>Fire & Emergency Services Instructor 2 - Chapter 5   |
| NFPA 1081, 2018                      | Incipient Facility Fire Brigade Member - Chapter 4<br>Advanced Exterior Facility Fire Brigade Member - Chapter 5<br>Interior Structural Facility Fire Brigade Member - Chapter 6<br>Facility Fire Brigade Leader - Chapter 7   |
| NFPA 1140, 2022<br>(Previously 1051) | Wildland Fire Fighter 1 - Chapter 4<br>Wildland Fire Fighter 2 - Chapter 5<br>Wildland Fire Officer 1 - Chapter 6<br>Wildland Fire Officer 2 - Chapter 7   |



# SAESI Accredited Training Providers

## EASTERN CAPE PROVINCE

| TRAINING PROVIDER                                       | CONTACT PERSON(S)                  | TEL NR.                      | EMAIL ADDRESS   | ACCREDITATION LEVELS   |
|---|------------------------------------|------------------------------|---|--|
| Buffalo City Fire & Emergency Services Training Academy | Graeme Shakespeare<br>Timothy Bunu | 043 705 9092<br>043 705 9040 | graeme@buffalocity.gov.za<br>timothy@buffalocity.gov.za | Fire Fighter 1- NFPA 1001<br>Fire Fighter 2 - NFPA 1001<br>Fire & Emergency Services Instructor 1 - NFPA 1041<br>Hazardous Materials / WMD Awareness - NFPA 1072<br>Hazardous Materials / WMD Operations Core - NFPA 1072<br>Hazardous Materials / WMD Operations MSC: Personal Protective Equipment<br>Hazardous Materials / WMD Operations MSC: Product Control - NFPA 1072<br>Fire Fighter 1- NFPA 1001 |
| Nelson Mandela Bay Municipality - Fire Training Centre  | Roger Goliath                      | 041 508 5518                 | rgoliath@mandelametro.gov.za                            | Fire Fighter 2 - NFPA 1001<br>Fire Officer 1 - NFPA 1021<br>Fire & Emergency Services Instructor 1 - NFPA 1041<br>Hazardous Materials / WMD Awareness - NFPA 1072<br>Hazardous Materials / WMD Operations Core - NFPA 1072<br>Hazardous Materials / WMD Operations MSC: Personal Protective Equipment<br>Hazardous Materials / WMD Operations MSC: Product Control - NFPA 1072                             |

## FREE STATE PROVINCE

| TRAINING PROVIDER  | CONTACT                          | TEL NR.                                      | EMAIL ADDRESS  | ACCREDITATION LEVELS  |
|--|----------------------------------|--|--|---|
| Goldfields Emergency Fire Training Academy                       | Karabo Tibane<br>Alsarina Tsoane | 068 429 1241<br>082 074 4224<br>057 354 4476 | finance.gefsta@gmail.com<br>kelumetse.moseme@gmail.com | Fire Fighter 1- NFPA 1001<br>Fire Fighter 2 - NFPA 1001<br>Fire & Emergency Services Instructor 1 - NFPA 1041<br>Hazardous Materials / WMD Awareness - NFPA 1072<br>Hazardous Materials / WMD Operations Core - NFPA 1072<br>Hazardous Materials / WMD Operations MSC: Personal Protective Equipment<br>Hazardous Materials / WMD Operations MSC: Product Control - NFPA 1072                               |
| Impact Emergency, Technology, Fire Rescue & EMS College - Welkom | Sharnice Krotz                   | 057 355 6571                                 | adminw@impactet1.co.za                                 | Fire Fighter 1- NFPA 1001<br>Fire Fighter 2 - NFPA 1001<br>Fire Officer 1 - NFPA 1021<br>Fire & Emergency Services Instructor 1 - NFPA 1041<br>Hazardous Materials / WMD Awareness - NFPA 1072<br>Hazardous Materials / WMD Operations Core - NFPA 1072<br>Hazardous Materials / WMD Operations MSC: Personal Protective Equipment<br>Hazardous Materials / WMD Operations MSC: Product Control - NFPA 1072 |

| TRAINING PROVIDER                        | CONTACT           | TEL NR.      | EMAIL ADDRESS  | ACCREDITATION LEVELS  |
|--|-------------------|--------------|--|---|
| Mangaung Fire & Rescue College           | Ola Bosaletse     | 078 940 4815 | ola.bosaletse@mangaung.co.za<br>bernice.mokgethi@mangaung.co.za<br>Nico.Erwee@mangaung.co.za | Fire Fighter 1- NFPA 1001<br>Fire Fighter 2 - NFPA 1001<br>Fire & Emergency Services Instructor 1 - NFPA 1041<br>Hazardous Materials / WMD Awareness - NFPA 1072<br>Hazardous Materials / WMD Operations Core - NFPA 1072<br>Hazardous Materials / WMD Operations MSC: Personal Protective Equipment<br>Hazardous Materials / WMD Operations MSC: Product Control - NFPA 1072 |
| Matjhabeng Fire & Rescue Training Centre | Francois Klaassen | 057 352 1840 | francois.klaassen@matjhabeng.co.za<br>sam.mogoera@matjhabeng.co.za                           | Fire Fighter 1- NFPA 1001<br>Fire Fighter 2 - NFPA 1001<br>Fire & Emergency Services Instructor 1 - NFPA 1041<br>Hazardous Materials / WMD Awareness - NFPA 1072<br>Hazardous Materials / WMD Operations Core - NFPA 1072<br>Hazardous Materials / WMD Operations MSC: Personal Protective Equipment<br>Hazardous Materials / WMD Operations MSC: Product Control - NFPA 1072 |

## GAUTENG PROVINCE

| TRAINING PROVIDER  | CONTACT   | TEL NR.      | EMAIL ADDRESS  | ACCREDITATION LEVELS  |
|--|---|--------------|--|---|
| City of Tshwane Emergency Services Department Training Academy | Andronicus Malatjie   | 012 330 6261 | andronicusm@tshwane.gov.za<br>tebogoma@tshwane.gov.za<br>kgolokom@tshwane.gov.za | Fire Fighter 1- NFPA 1001<br>Fire Fighter 2 - NFPA 1001<br>Fire & Emergency Services Instructor 1 - NFPA 1041<br>Hazardous Materials / WMD Awareness - NFPA 1072<br>Hazardous Materials / WMD Operations Core - NFPA 1072<br>Hazardous Materials / WMD Operations MSC: Personal Protective Equipment<br>Hazardous Materials / WMD Operations MSC: Product Control - NFPA 1072   |
| Ekurhuleni Emergency Services Training Academy - Part 1        | Theresa Geldenhuys<br>Gerald Moswathupa<br>Marlene Moonsamy | 011 999 5811 | eesta.info@ekurhuleni.gov.za   | Fire Fighter 1- NFPA 1001<br>Fire Fighter 2 - NFPA 1001<br>Driver/Operator Fire Pump - NFPA<br>Driver/Operator Aerial Device - NFPA<br>Rope Rescue Awareness - NFPA 1006<br>Rope Rescue Operations - NFPA 1006<br>Rope Rescue Technician - NFPA 1006<br>Structural Collapse Rescue Awareness - NFPA 1006<br>Structural Collapse Rescue Operations - NFPA 1006<br>Structural Collapse Rescue Technician - NFPA 1006<br>Confined Space Rescue Awareness - NFPA 1006<br>Confined Space Rescue Operations - NFPA 1006<br>Confined Space Rescue Technician - NFPA 1006 |

| TRAINING PROVIDER   | CONTACT          | TEL NR.                      | EMAIL ADDRESS           | ACCREDITATION LEVELS   |
|---|------------------|------------------------------|-------------------------|--|
| Ekurhuleni Emergency Services Training Academy - Part 2             |                  |                              |                         | Common Passenger Vehicle Rescue Awareness - NFPA 1006<br>Common Passenger Vehicle Rescue Operations - NFPA 1006<br>Common Passenger Vehicle Rescue Technician - NFPA 1006<br>Heavy Vehicle Rescue Awareness - NFPA 1006<br>Heavy Vehicle Rescue Operations - NFPA 1006<br>Heavy Vehicle Rescue Technician - NFPA 1006<br>Wilderness Search & Rescue Awareness - NFPA 1006<br>Wilderness Search & Rescue Operations - NFPA 1006<br>Wilderness Search & Rescue Technician - NFPA 1006<br>Trench Rescue Awareness - NFPA 1006<br>Trench Rescue Operations - NFPA 1006<br>Trench Rescue Technician - NFPA 1006<br>Machine Rescue Awareness - NFPA<br>Machine Rescue Operations - NFPA<br>Machine Rescue Technician - NFPA<br>Swiftwater Rescue Awareness - NFPA<br>Swiftwater Rescue Operations - NFPA<br>Swiftwater Rescue Technician - NFPA<br>Fire Officer 1 - NFPA 1021<br>Fire Officer 2 - NFPA 1021<br>Public Information Officer - NFPA 1026<br>Fire Investigator - NFPA 1033<br>Fire & Life Safety Educator 1 - NFPA<br>Fire & Life Safety Educator 2 - NFPA<br>Fire & Emergency Services Instructor 1 - NFPA 1041<br>Fire & Emergency Services Instructor 2 - NFPA 1041 |
| Ekurhuleni Emergency Services Training Academy - Part 3             |                  |                              |                         | Hazardous Materials / WMD Awareness - NFPA 1072<br>Hazardous Materials / WMD Operations Core - NFPA 1072<br>Hazardous Materials / WMD Operations MSC: Personal Protective Equipment<br>Hazardous Materials / WMD Operations MSC: Product Control - NFPA 1072<br>Hazardous Materials / WMD technician NFPA 1072   |
| Impact Emergency Technology Fire, Rescue & EMS College - Roodepoort | Tshediso Thabete | 012 543 3904<br>073 813 8999 | adminp@kernbridge.co.za | Fire Fighter 1- NFPA 1001<br>Fire Fighter 2 - NFPA 1001<br>Fire & Emergency Services Instructor 1 - NFPA 1041<br>Hazardous Materials / WMD Awareness - NFPA 1072<br>Hazardous Materials / WMD Operations Core - NFPA 1072<br>Hazardous Materials / WMD Operations MSC: Personal Protective Equipment<br>Hazardous Materials / WMD Operations MSC: Product Control - NFPA 1072  |

| TRAINING PROVIDER                               | CONTACT                              | TEL NR.                                      | EMAIL ADDRESS  | ACCREDITATION LEVELS  |
|---|--------------------------------------|--|--|---|
| Military Aviation Rescue & Fire Fighting School | Mr C Piek                            | 012 312 2531                                 | dbssarffs@gmail.com  | Fire Fighter 1- NFPA 1001<br>Fire Fighter 2 - NFPA 1001<br>Fire & Emergency Services Instructor 1 - NFPA 1041<br>Hazardous Materials / WMD Awareness - NFPA 1072<br>Hazardous Materials / WMD Operations Core - NFPA 1072<br>Hazardous Materials / WMD Operations MSC: Personal Protective Equipment<br>Hazardous Materials / WMD Operations MSC: Product Control - NFPA 1072 |
| Pro Ethnos Fire & Rescue Training               | Jurie van Staden<br>Mienkie Ferreira | 068 281 9193<br>081 726 6806<br>013 880 2023 | trainingatproethnos@gmail.com<br>info@proethnosfrt.co.za<br>response@proethnosfrt.co.za<br>training@proethnosfrt.co.za | Fire Fighter 1- NFPA 1001<br>Fire Fighter 2 - NFPA 1001<br>Hazardous Materials / WMD Awareness - NFPA 1072<br>Hazardous Materials / WMD Operations Core - NFPA 1072<br>Hazardous Materials / WMD Operations MSC: Personal Protective Equipment<br>Hazardous Materials / WMD Operations MSC: Product Control - NFPA 1072   |
| Rescu-Life Africa Training Academy              | Thandi Mawetsi                       | 060 604 2769                                 | thandi@resculife.co.za<br>admin@resculife.co.za  | Fire Fighter 1- NFPA 1001<br>Fire Fighter 2 - NFPA 1001<br>Fire & Emergency Services Instructor 1 - NFPA 1041<br>Hazardous Materials / WMD Awareness - NFPA 1072<br>Hazardous Materials / WMD Operations Core - NFPA 1072<br>Hazardous Materials / WMD Operations MSC: Personal Protective Equipment<br>Hazardous Materials / WMD Operations MSC: Product Control - NFPA 1072 |

### KWAZULU NATAL PROVINCE

| TRAINING PROVIDER   | CONTACT                           | TEL NR.                      | EMAIL ADDRESS   | ACCREDITATION LEVELS  |
|---|-----------------------------------|------------------------------|---|---|
| City of Umhlatuze Fire, Rescue & Disaster Training Centre | Oscar Mogaka<br>Yacoob Dawood     | 035 907 5731<br>035 907 5725 | makgaka@umhlathuze.gov.za<br>dawoody@umhlathuze.gov.za        | Fire Fighter 1- NFPA 1001<br>Fire Fighter 2 - NFPA 1001<br>Fire & Emergency Services Instructor 1 - NFPA 1041<br>Hazardous Materials / WMD Awareness - NFPA 1072<br>Hazardous Materials / WMD Operations Core - NFPA 1072<br>Hazardous Materials / WMD Operations MSC: Personal Protective Equipment<br>Hazardous Materials / WMD Operations MSC: Product Control - NFPA 1072 |
| Ethekwini Fire & Emergency Training Centre                | Cosmos Ngema<br>Confidence Gumede | 031 311 5942<br>031 322 2904 | cosmos.ngema@durban.gov.za<br>confidence.gumede@durban.gov.za | Fire Fighter 1- NFPA 1001<br>Fire Fighter 2 - NFPA 1001<br>Hazardous Materials / WMD Awareness - NFPA 1072<br>Hazardous Materials / WMD Operations Core - NFPA 1072<br>Hazardous Materials / WMD Operations MSC: Personal Protective Equipment<br>Hazardous Materials / WMD Operations MSC: Product Control - NFPA 1072   |

| TRAINING PROVIDER                         | CONTACT                                       | TEL NR.                      | EMAIL ADDRESS  | ACCREDITATION LEVELS   |
|---|---|------------------------------|--|--|
| Rural Metro Emergency Management Services | Bonisile Precious Fanie<br>Dumisani Makathini | 033 413 4040<br>033 345 0080 | training@ruralmetrosa.com<br>dumisani@ruralmetrosa.com | Fire Fighter 1 - NFPA 1001<br>Fire Fighter 2 - NFPA 1001<br>Fire & Emergency Services Instructor 1 - NFPA 1041<br>Hazardous Materials / WMD Awareness - NFPA 1072<br>Hazardous Materials / WMD Operations Core - NFPA 1072<br>Hazardous Materials / WMD Operations MSC: Personal Protective Equipment<br>Hazardous Materials / WMD Operations MSC: Product Control - NFPA 1072 |

| TRAINING PROVIDER  | CONTACT          | TEL NR.                      | EMAIL ADDRESS                               | ACCREDITATION LEVELS   |
|--|------------------|------------------------------|---|--|
| Vhembe District Municipality Fire & Rescue Training Centre | Shonisani Mphuma | 015 961 6803<br>082 401 5169 | mphumas@vhembe.gov.za<br>mphuma74@gmail.com | Fire Fighter 1 - NFPA 1001<br>Fire Fighter 2 - NFPA 1001<br>Hazardous Materials / WMD Awareness - NFPA 1072<br>Hazardous Materials / WMD Operations Core - NFPA 1072<br>Hazardous Materials / WMD Operations MSC: Personal Protective Equipment<br>Hazardous Materials / WMD Operations MSC: Product Control - NFPA 1072 |

### LIMPOPO PROVINCE

| TRAINING PROVIDER   | CONTACT                      | TEL NR.                                      | EMAIL ADDRESS                                      | ACCREDITATION LEVELS   |
|---|------------------------------|--|--|--|
| EMCARE Training Academy   | Jason Delport                | 015 295 4578                                 | admin@emcare.org                                   | Fire Fighter 1 - NFPA 1001<br>Fire Fighter 2 - NFPA 1001<br>Hazardous Materials / WMD Awareness - NFPA 1072<br>Hazardous Materials / WMD Operations Core - NFPA 1072<br>Hazardous Materials / WMD Operations MSC: Personal Protective Equipment<br>Hazardous Materials / WMD Operations MSC: Product Control - NFPA 1072   |
| Polokwane Fire & Rescue Training Centre   | Theo Vermaak<br>Daniel Leeuw | 081 582 2112<br>083 662 3844<br>015 290 2639 | theov@polokwane.gov.za<br>daniell@polokwane.gov.za | Fire Fighter 1 - NFPA 1001<br>Fire Fighter 2 - NFPA 1001<br>Fire & Emergency Services Instructor 1 - NFPA 1041<br>Hazardous Materials / WMD Awareness - NFPA 1072<br>Hazardous Materials / WMD Operations Core - NFPA 1072<br>Hazardous Materials / WMD Operations MSC: Personal Protective Equipment<br>Hazardous Materials / WMD Operations MSC: Product Control - NFPA 1072 |
| Sekhukhune District Municipality Emergency Management Services Training Academy | Nomsa Mopaila                | 073 397 7866<br>013 262 7411                 | mapailanomsa@gmail.com                             | Fire Fighter 1 - NFPA 1001<br>Fire Fighter 2 - NFPA 1001<br>Fire & Emergency Services Instructor 1 - NFPA 1041<br>Hazardous Materials / WMD Awareness - NFPA 1072<br>Hazardous Materials / WMD Operations Core - NFPA 1072<br>Hazardous Materials / WMD Operations MSC: Personal Protective Equipment<br>Hazardous Materials / WMD Operations MSC: Product Control - NFPA 1072 |

|  |  |              |   |  |
|--|--|--------------|---|--|
| Sasol Secunda Emergency Management Training Academy - Part 1 | Boikanyo Motlogelwa<br>Sakkie Joubert<br>Isabel de Jongh | 017 610 6016 | boikanyo.motlogelwa@sasol.com<br>sakkie.joubert@sasol.com<br>isabel.dejongh@sasol.com | Fire Fighter 1 - NFPA 1001<br>Fire Fighter 2 - NFPA 1001<br>Driver/Operator Fire Pump - NFPA<br>Driver/Operator Aerial Device - NFPA<br>Rope Rescue Awareness - NFPA 1006<br>Rope Rescue Operations - NFPA 1006<br>Rope Rescue Technician - NFPA 1006<br>Common Passenger Vehicle Rescue Awareness - NFPA 1006<br>Common Passenger Vehicle Rescue Operations - NFPA 1006<br>Common Passenger Vehicle Rescue Technician - NFPA 1006<br>Heavy Vehicle Rescue Awareness - NFPA 1006<br>Heavy Vehicle Rescue Operations - NFPA 1006<br>Heavy Vehicle Rescue Technician - NFPA 1006<br>Wilderness Search & Rescue Awareness - NFPA 1006<br>Wilderness Search & Rescue Operations - NFPA 1006<br>Wilderness Search & Rescue Technician - NFPA 1006<br>Machinery Rescue Awareness - NFPA<br>Machinery Rescue Operations - NFPA<br>Machinery Rescue Technician - NFPA<br>Fire Investigator - NFPA 1033<br>Fire & Emergency Services Instructor 1 - NFPA 1041<br>Fire & Emergency Services Instructor 2 - NFPA 1041 |
|--|--|--------------|---|--|

|  |  |  |  |  |
|--|--|--|--|--|
| Sasol Secunda Emergency Management Training Academy - Part 2 |  |  |  | Hazardous Materials / WMD Awareness - NFPA 1072<br>Hazardous Materials / WMD Operations Core - NFPA 1072<br>Hazardous Materials / WMD Operations MSC: Personal Protective Equipment<br>Hazardous Materials / WMD Operations MSC: Product Control - NFPA 1072<br>Hazardous Materials / WMD technician NFPA 1072<br>Incipient Facility Fire Brigade Member - NFPA 1081<br>Advanced Exterior Facility Fire Brigade Member - NFPA 1081<br>Interior Structural Facility Fire Brigade Member - NFPA 1081<br>Facility Fire Brigade Leader - NFPA - 1081 |
|--|--|--|--|--|

## NORTHERN CAPE PROVINCE

| TRAINING PROVIDER                                    | CONTACT             | TEL NR.                      | EMAIL ADDRESS                | ACCREDITATION LEVELS   |
|--|---------------------|------------------------------|------------------------------|--|
| Sol Plaatjie Emergency Training Centre               | Ntanti John Sephiri | 053 832 4214<br>053 832 4213 | nsephiri@solplaatjie.org.za  | Fire Fighter 1 - NFPA 1001<br>Fire Fighter 2 - NFPA 1001<br>Driver/Operator Fire Pump - NFPA<br>Fire Officer 1 - NFPA 1021<br>Fire Officer 2 - NFPA 1021<br>Fire & Emergency Services Instructor 1 - NFPA 1041<br>Fire & Emergency Services Instructor 2 - NFPA 1041<br>Hazardous Materials / WMD Awareness - NFPA 1072<br>Hazardous Materials / WMD Operations Core - NFPA 1072<br>Hazardous Materials / WMD Operations MSC: Personal Protective Equipment<br>Hazardous Materials / WMD Operations MSC: Product Control - NFPA 1072 |
| Rustenburg Emergency and Disaster Management Academy | Kabelo Modimoeng    | 014 590 3818<br>063 680 2613 | kmodimoeng@rustenburg.gov.za | Fire Fighter 1 - NFPA 1001<br>Fire Fighter 2 - NFPA 1001<br>Fire & Emergency Services Instructor 1 - NFPA 1041<br>Hazardous Materials / WMD Awareness - NFPA 1072<br>Hazardous Materials / WMD Operations Core - NFPA 1072<br>Hazardous Materials / WMD Operations MSC: Personal Protective Equipment<br>Hazardous Materials / WMD Operations MSC: Product Control - NFPA 1072   |

## WESTERN CAPE PROVINCE

| TRAINING PROVIDER                            | CONTACT                        | TEL NR.                      | EMAIL ADDRESS  | ACCREDITATION LEVELS   |
|--|--------------------------------|------------------------------|--|--|
| Cape Winelands Fire & Rescue Training Centre | Heinrich Louw<br>Shareeka Pool | 072 571 1219<br>083 356 0469 | Heinrich@capewinelands.gov.za<br>Shareeka@capewinelands.gov.za | Fire Fighter 1 - NFPA 1001<br>Fire Fighter 2 - NFPA 1001<br>Fire Officer 1 - NFPA 1021<br>Fire & Emergency Services Instructor 1 - NFPA 1041<br>Hazardous Materials / WMD Awareness - NFPA 1072<br>Hazardous Materials / WMD Operations Core - NFPA 1072<br>Hazardous Materials / WMD Operations MSC: Personal Protective Equipment<br>Hazardous Materials / WMD Operations MSC: Product Control - NFPA 1072 |
| Drakenstein Fire & Rescue Training Academy   | Dereck Peceur                  | 021 807 4728                 | dereck@drakenstein.gov.za                                      | Fire Fighter 1 - NFPA 1001<br>Fire Fighter 2 - NFPA 1001<br>Fire & Emergency Services Instructor 1 - NFPA 1041<br>Hazardous Materials / WMD Awareness - NFPA 1072<br>Hazardous Materials / WMD Operations Core - NFPA 1072<br>Hazardous Materials / WMD Operations MSC: Personal Protective Equipment<br>Hazardous Materials / WMD Operations MSC: Product Control - NFPA 1072                               |

# Index to Municipal/provincial/industrial fire fighting services

|                             |     |
|-----------------------------|-----|
| Eastern Cape                | 118 |
| Free State                  | 121 |
| Gauteng                     | 125 |
| Kwazulu Natal               | 128 |
| Limpopo                     | 132 |
| Mpumalanga                  | 134 |
| Northern Cape               | 137 |
| North West                  | 139 |
| Western Cape                | 141 |
| Industrial Fire Departments | 146 |
| Department of Health        | 155 |
| NDMC                        | 156 |
| Department of Defence       | 157 |
| Associations / Institutes   | 158 |

# EASTERN CAPE

## AMAKHATHI MUNICIPALITY FIRE DEPARTMENT

### AREAS UNDER CONTROL

Stutterheim, Cathcart, Kei Road, Amabele

### CONTACT INFORMATION

Maclean Str Stutterheim Private Bag X4002 Stutterheim 4930  
Tel no (043) 683-1100 Fax no (043) 683-2577

### Fire Services:

Tel no (043) 683-1100 /5000

### Community and Protection Services:

Tel no (043) 492 1273

### Protection Services:

Tel no (043) 683 1390

### Cathcart Fire Station

Main Str Cathcart

PO Box 35 Cathcart 5310

Tel no office hours (045) 843-1022 Fax no (045) 843-1529

### STATISTICS

Size of area: Municipal area 6400 sq kms

Population: 142 525

Value of area protecting: R2000 000 000.00

Fire stations: 2

## AMATHOLE DISTRICT MUNICIPALITY FIRE DEPARTMENT

### CONTACT INFORMATION

Waverly Office Park, 3-33 Phillip Frame, Chiselhurst 5247

PO Box 320, East London, 5200

Tel no (043) 701 4000 Fax no (043) 721 2874

## BLUE CRANE ROUTE MUNICIPALITY FIRE DEPARTMENT

### AREAS UNDER CONTROL

Somerset East, Cookhouse, Pearston

### CONTACT INFORMATION

67 Nojoli Str Somerset East

PO Box 21 Somerset East 5850

Tel no (042) 243-1333 / 6400 Fax No (042) 243 0633

### STATISTICS

Population: ± 20 000

## BUFFALO CITY METROPOLITAN MUNICIPALITY

### AREAS UNDER CONTROL

Bisho, King William's Town, East London

### CONTACT INFORMATION

47 Fleet Street, East London

PO Box 673 East London 5201

Tel no (043) 705 9005/6/7 Fax no (043) 742 0092

### Health, Public Safety & Emergency Services:

Tel no (043) 705 1895

### Emergency and Fire Services:

Tel no (043) 705 9043 Tel no (043) 705-9001

### Training Services:

Tel no (043) 705 9090

### Disaster Management:

Tel no (043) 743 7118

### STATISTICS

Size of area protecting: 2,430 sq kms

Population: 880 000

## DR BEYERS NAUDE LOCAL MUNICIPALITY

### AREAS UNDER CONTROL

Graaff-Reinet, Aberdeen, Nieu Bethesda, Jansenville, Klapplaat, Willowmore, Steytleville, Rietbron (EC101)

### CONTACT INFORMATION

Head Offices: 5 Somerset Street, Graaff-Reinet, 6280

Tel no office hours: (049) 807 5700 / 083 7549908

Fax no (049) 892 4319 / 086 716 1978

### Satellite Office 1:

17 Voortrekker Street, Aberdeen, 6270

Tel no (049) 846 0014/5 After hours: 073 005 5448

### Satellite office 2:

Muller Street, Nieu Bethesda, 6286

Tel no (049) 841 1659 After hours: (049) 8411608 / 079 109 7139

### Satellite office 3:

34 Main Street, Jansenville, 6265

Tel no (049) 836 0021 After hours (SAPS): (049) 836 0013

### Satellite office 4:

Knysna Street, Willowmore, 6446

Tel no (044) 923 1004 After hours (SAPS): (044) 923 8100

### STATISTICS

Size of area: 28,653 square km in extent and a population density of 2.8 persons per square km

Population: Graaff-Reinet – 35,672, Aberdeen – 7,163, Nieu Bethesda – 1,540, Jansenville – 8,577, Willowmore – 11,736, Rietbron – 1,184 and non-urban 13,419 with a total of 79,291

## EMALAHLENI LOCAL MUNICIPALITY

### CONTACT INFORMATION

37 Indwe Road Lady Frere Eastern Cape 5410

Private Bag X 1161 Ladyfrere, 5410

### Head Office: Tel no (047) 878 0020 / (047) 808 0905

Fax no (047) 878 0112

### Dordrecht Office: Tel no (045) 943 1017

Email: mrwebin@emalahlenilm.gov.za

### STATISTICS

Population: 12 500

Size of area: 10 sq kms

## ENOCH MGJIMA MUNICIPALITY & FIRE SERVICES

### AREAS UNDER CONTROL

Queenstown

### CONTACT INFORMATION

#### Head Office

8 Owen Str Queenstown

Private Bag X7111 Queenstown 5320

Tel no (045) 807-2601 / 2606 Fax no (045) 807-2618

#### Fire Brigade

Tel no: (045) 839 2233

1 New Street, Queenstown

#### Traffic Department: 27 Owen Street Queenstown

### STATISTICS

Size of area: 4444 sq kms

Population: 200 000

Fire stations:1

## GREAT KEI MUNICIPALITY FIRE DEPARTMENT

### AREAS UNDER CONTROL

Kei Mouth, Cintsa, Haga Haga, Morgansbay

### CONTACT INFORMATION

17 Main St (Cnr Station Str) Komga

Private Bag X 2 Komga 4950

Head Office: Tel no (043) 831-1028 / 831-5700

Fax no (043) 831-1306 Cell no 082 778 8500

Email: info@greatkeilm.gov.za

### Fire Department Komga:

Tel no (043) 831 1084

## INXUBA YETHEMBA MUNICIPALITY

### AREAS UNDER CONTROL

Cradock, Middleburg

### CONTACT INFORMATION

#### Cradock Fire Station

1 JA Calata St Cradock,

PO Box 24 Cradock 5880

Tel no (048) 801-5000 Fax no (048) 881-1421

Email: mm@iym.gov.za

#### Middelburg Fire Station

Stockenstroom Str Middelburg (Townhall)

Van Niekerk Str, Middelburg

PO Box 55 Middelburg 5900

Tel no (049) 802 1300 / 802 1368 Fax no (049) 842-1443

### STATISTICS

Population: 49 283

## JOE GOABI DISTRICT MUNICIPALITY DISASTER MANAGEMENT AND FIRE RESCUE DEPARTMENT

### AREAS UNDER CONTROL

*Walter Sisulu Local Municipality:* Aliwal North, Jamestown,

Burgersdorp, Steynsburg & Venterstad

*Senqu Local Municipality:* Lady Grey, Sterkspruit, Barkly East,

Rhodes & Rossouw

*Elundini Local Municipality:* Mount Fletcher, Maclear & Ugjie,

### CONTACT INFORMATION

#### District Disaster Management & Fire Rescue Main Office

Private Bag X102 Barkly East 9786

Tel no (045) 979 3137 Fax no (045) 971 0251

#### Walter Sisulu Local Municipality

Tel no (051) 633-2313

#### Gariep Disaster Management

Tel no (051) 653 0770

#### Elundini Disaster Management

Tel no (039) 257 0062

#### Senqu Disaster Management

Tel and fax no (051) 603 0005

### STATISTICS

Size of area: 26518 sq kms

Population: 308365

## KING SABATA DALINDYEBO (KSD) MUNICIPALITY

### AREAS UNDER CONTROL

Mithatha Local Municipality - Mqanduli Fire & Emergency Services

### CONTACT INFORMATION

Durham Str Mithatha

PO Box 45 Mithatha 5099

Tel no (047) 532 4444 / 2222 Fax no (047) 501-4152

Control Centre Emergency no (047) 501-4444

## KOUGA MUNICIPALITY FIRE DEPARTMENT

### AREA UNDER CONTROL

Jeffreys Bay, Humansdorp, St Francis Bay, Hankey, Patensie, Loerie - entire EC108 area)

### CONTACT INFORMATION

#### Humansdorp Fire Department

R330 Hankey Rd, Humansdorp,

PO Box 21 Jeffreys Bay 6330

Tel no (042) 291-0283 Emergency no (042) 291-0250

#### Law Enforcement, Traffic and Security:

Tel no (042) 200 8350 After hours (042) 291-0250

#### Traffic:

Heugh Street Humansdorp

Tel no (042) 200 8350

Ambulance: Tel no (042) 291-0020 / 21

## KOUKAMMA MUNICIPALITY FIRE DEPARTMENT

### AREAS UNDER CONTROL

Joubertina, Kareedouw

### CONTACT INFORMATION

5 Keet Str Kareedouw,

Private Bag X011 Kareedouw 6400

Tel no (042) 288-7270 Fax no (042) 288-0797

### Protection Services:

Tel no (042) 288 7200/7273

## MAKANA MUNICIPALITY DEPARTMENT OF FIRE & RESCUE SERVICES

### AREAS UNDER CONTROL

Grahamstown, Alicedale, Riebeeck East, Fort Brown, Salem Carlisle Bridge

### CONTACT INFORMATION

PO Box 176 Grahamstown 6140

Tel no (046) 603-6000 Fax no (046) 622-7494

*Municipal Manager*

Tel no (046) 603-6132 Fax no (046) 622-9700

*Community and Social Services*

Tel no (046) 603-6148

#### Fire Service

Tel no (046) 603-6000

*Disaster Management*

Tel no (046) 603-6051 Fax no (046) 622-9474

### STATISTICS

Size of area: 4221 sqkms

Population: ± 120 000

## MATATIELE PUBLIC SAFETY

### AREAS UNDER CONTROL

Matatiele, Maluti, Cedarville)

102 Main Str, Matatiele

PO Box 35 Matatiele 4730

Tel no (039) 737-8100 / 3135 Fax no (039) 737-3611

Email: info@matatiele.gov.za

#### Municipal Management:

Tel no (039) 737 8104

#### Disaster & Fire Department:

Tel no (039) 737 9660

Emergency: 039 256 0610 Cell no 083 785 1944

#### Public Safety:

Tel no (039) 737 9660 Cell no 083 785 1944

Fax no 086 269 1191

### STATISTICS

Size of area: 3 000 sq kms

Population: 500 000

**NDLAMBE MUNICIPALITY FIRE & EMERGENCY SERVICES**

**AREAS UNDER CONTROL**

Port Alfred, Bathurst, Kleinemonde, Kenton-On-Sea, Boknes, Bushmansriver and Alexandria, Cannon Rocks

**CONTACT INFORMATION**

Main Fire Station: Cnr Bathurst Street & R72 Port Alfred PO Box 13 Port Alfred 6170

**Satellite Fire Station:**

R72 Bushmansrivermouth

Admin Tel no (046) 604 5525/ 6736 Emergency no (046) 624 1111

**Community Protection Services:**

Tel no (046) 604 5528 ext 251

**STATISTICS**

Population: approximate 63000

Size of area : approximately 200 000 Square Km

**NELSON MANDELA BAY MUNICIPALITY FIRE AND EMERGENCY SERVICES**

**CONTACT INFORMATION**

Tel: (041) 506-1911

PO Box 116, Port Elizabeth, 6000

**Fire and Emergency Services**

PO Box 579 Port Elizabeth, 6000

Emergency tel no all stations (041) 585-1555

Control room tel no (041) 508-5552/5566

Administration tel no all stations (041) 585-2311

**STATISTICS**

Size of area: 1950sq kms

Population: 1 152 115

Value of area Protecting: R136.7 billion

Fire stations: 9

**FIRE STATIONS**

**South End Fire Station**

Walmer Boulevard, South End, Port Elizabeth

**Sidwell Fire Station**

Cadle Street, Sidwell, Port Elizabeth

**Miramar Fire Station**

Genadendal Road, Miramar, Port Elizabeth

**Govan Mbeki Fire Station**

Old Uitenhage Road, Govan Mbeki, Port Elizabeth

**Motherwell Fire Station**

Addo Rd, Motherwell Port Elizabeth

**Uitenhage Fire Station**

Cuyler Street, Uitenhage

**Greenbushes Fire Station**

Lakeside Road, Greenbushes, Port Elizabeth

**KwaNobuhle Fire Station**

Ponanatini Road, KwaNobuhle, Uitenhage

**KwaZakhele Fire Station**

Qunta Street, KwaZakhele, Port Elizabeth

**Markman Training Centre**

Ranger Street, Markman Industria, Port Elizabeth

Tel no (041) 508 5660

**OR TAMBO DISTRICT MUNICIPALITY FIRE AND EMERGENCY SERVICES**

**AREAS UNDER CONTROL**

Mthatha (KSD), Ntabankulu, Ingquza Hill (Flagstaff & Lusikisiki), Mbizana (Bizana), Port St Johns, Nyandeni (Libode & Nqeleni) and Mhlontlo (Qumbu & Tsolo)

**OR Tambo District Municipality Offices:**

Magwa House, Nelson Mandela Drive Mthatha

Private Bag X6043 Mthatha 5099

Email: info@ortambodm.gov.za

**Disaster Management Control Centre:**

Tel no (047) 501-6494 Fax no (047) 532-2158

**Fire & EMS:**

Tel no (047) 501-6475 Cell no 083 570 7215

Fax no (086) 6111827

Email: fire@ortambodm.gov.za

**RAYMOND MHLABA LOCAL MUNICIPALITY**

**AREAS UNDER CONTROL**

Bedford, Adelaide

**CONTACT INFORMATION**

Market Square, Adelaide

Private Bag X 350 Adelaide, 5760

Tel no (046) 684 0034 Fax no (046) 684 1931

**Community Sevices:**

Tel no (046) 645 7402

**Traffic Services/SAPS**

Tel no (046) 684 0030 Fax no (046) 685-0272

**STATISTICS**

Size of area: 44 sq kms

Population: 17 606

**SUB STATIONS**

**Bedford substation**

Donkin Str Bedford PO Box 24 Bedford 5780

Tel no (046) 685-0076 Fax no (046) 685-0563

**SAKHISIZWE MUNICIPALITY**

**AREAS UNDER CONTROL**

Elliot, Cala

**CONTACT INFORMATION**

ERF 5556 Umthatha Rd Cala

PO Box 26 Cala 5455

Tel no (047) 877-5200 Fax no (047) 877-0000

**Disaster Management:**

Tel no (047) 877 5200

**Elliot Office**

15 Maclear Rd, Elliot

Tel no (045) 931-1011 Fax no (045) 931-1361

**SUNDAYS RIVER VALLEY MUNICIPALITY FIRE DEPARTMENT**

**AREAS UNDER CONTROL**

Kirkwood

**CONTACT INFORMATION**

30 Middle Str Kirkwood

PO Box 47 Kirkwood 6120

Municipality switchboard: Tel no (042) 230-7700

Fax no (042) 230-1799

**Corporate Services:**

Tel no (042) 230-7729

Email: tembekilem@srvm.gov.za

**Community Services:**

Tel no (042) 230-7700 / 7737

**Infrastructure Planning and Development:**

Tel no 042-230-7735

**Fire Services:**

Tel no (042) 230 0942

**Traffic Services:**

Tel no (042) 230 7700 / 7714

**STATISTICS**

Size of area: 5854,9 sq kms

Population: 51 581

# FREE STATE

**DIHLABENG PUBLIC SAFETY**

**AREAS UNDER CONTROL**

Bethlehem, Clarens, Fouriesburg, Paul Roux, Rosendal

**CONTACT INFORMATION**

PO Box 551 Bethlehem 9700

Tel no (058) 303-5732 / 0364 / 5161 Fax no 086 508 0200

Email: fireadmin@dihlabeng.co.za

**STATISTICS**

Size of area: 620 sq kms

Population: 352 000

Value of area protecting: R15 Billion

**FEZILE DABI DISTRICT MUNICIPALITY FIRE DEPARTMENT**

**AREAS UNDER CONTROL**

Frankfort, Villiers, Tweeling, Cornelia

**CONTACT INFORMATION**

Fezile Dabi District Bulding, John Vorster Rd, Sasolburg

PO Box 10 Sasolburg, 1947

Tel no (016) 970 8891 / (058) 813 1500

**Environmental Health & Emergency Services:**

Tel no (016) 970 8874

**Administration:**

Tel no (016) 970 8873

**KOPANONG LOCAL MUNICIPALITY FIRE DEPARTMENT**

**AREAS UNDER CONTROL**

Bethulie, Edenburg, Fauresmith, Gariep Dam, Jagersfontein, Philippolis, Reddersburg, Trompsburg, Springfontein

**CONTACT INFORMATION**

20 Louw Str Trompsburg

Private Bag X 23 Trompsburg 9913

Tel no (051) 713-9200 / 9201 Fax no (051) 713-0292

**Corporate Services:**

Tel no (051) 713-9205

**UNITS**

**Bethulie Unit**

Louis Trichardt Sq Voortrekker Str Bethulie

Tel no (051) 713 9219

**Edenburg Unit**

Cnr Loop & Church Sts Edenburg

Tel no (051) 713 9220

**Fauresmith Unit**

21 Voortrekker Str Fauresmith

Tel no (051) 713 9223

**Jagersfontein Unit**

Market Sq Jagersfontein

Tel no (051) 713 9222

**Philippolis Unit**

50 Kok Str Philippolis 9970

Tel no (051) 713 9224

**Reddersburg Unit**

6 Oranje Str Tel no (051) 713 9221

**Springfontein Unit**

11B Cnr Christia Crause & Van Riebeeck Str Springfontein

Tel no (051) 713 9225

**Gariep Dam Unit**

3 Patrys Str, Fonner Park, 9922

Tel: (051) 713 9227

**STATISTICS**

Size of area: 100 sq kms

Population: 85 000

**LETSEMENG MUNICIPALITY FIRE DEPARTMENT**

**AREAS UNDER CONTROL**

Koffiefontein, Jacobsdal, Luckhoff, Oppersmansgrond, Petrusburg

**CONTACT INFORMATION**

7 Groot Trek Str Koffiefontein

Private Bag X3 Koffiefontein 9986

Tel no (053) 330 0200

Email: info@letsemeng.gov.za

**STATIONS**

**Jacobsdal Sub-Station**

Andries Pretorius Str

PO Box 4 Jacobsdal 8710

Tel no (053) 330 0271

**Luckhoff Sub-Station**

Bosman Ave Luckhoff

PO Box 7 Luckhoff 9982

Tel no (053) 330 0280

**STATISTICS**

Size of area: 140 sq kms

Population: 17 000

**MALUTI A PHOFUNG FIRE AND EMERGENCY SERVICES**

**AREAS UNDER CONTROL**

Kestel, Harrismith, Qwa Qwa Rural, Phuthaditjhaba MAP Farms

**CONTACT INFORMATION**

Private Bag X 805 Witsieshoek 9870

Tel no (Fire) (058) 713-1777 Fax no (058) 713-1124

**Public Safety & Transport:**

Tel no (058) 718-3700 / 622 1061 Fax no (058) 718-3775/7

(Operational) Centralised communication centre:

Cnr Bergoord Rd and Cash & Carry

Fire safety & prevention, fire training, fire operations and disaster management:

Tel no (058) 713-1777 / 0813 / 1110 Fax no (058) 713-1124

**FIRE STATIONS**

**Phuthaditjhaba Main Station**

Tel no (058) 713 1777/ (058) 713 0813/9 Fax no (058) 713 1124

**Harrismith Sub-Station**

Tel no (058) 622-3318 Fax no (058) 713-1124

**STATISTICS**

Size of area: 4470 sq kms

Population: 385 413

Number of Fire Stations: 2

**MANGAUNG FIRE & EMERGENCY SERVICE**

**AREAS UNDER CONTROL**

Thaba Nchu & Botshabelo, de Wetsdorp, Wepener & van Stadensrus, Naledi

**CONTACT INFORMATION**

**Head Quarters and Administration:**

5th Floor Gabriel Dichabe Building, Charles Street Bloemfontein

PO Box 196 Bloemfontein 9300

**Central Fire Station**

President Brand Str Bloemfontein

Tel no (051) 405 8258 Fax no (051) 406-6487

*Emergency / Fire Services:*  
Tel no (051) 406 6305 / 6480 / 6474 / 6478 / (051) 873 3066  
Fax no (051) 406-6487

*Disaster Management:*  
Tel no (051) 406-6353

#### **STATISTICS**

*Size of area:* ± 9 624 sq kms  
*Population:* 782 000  
Value of area protecting: R 98 242 178.00

#### **MANTSOPA MUNICIPALITY DISASTER MANAGEMENT DEPARTMENT**

##### **AREAS UNDER CONTROL**

Ladybrand, Excelsior, Tweespruit, Hobhouse, Thaba Patchoa

##### **CONTACT INFORMATION**

*Ladybrand Fire Department*  
38 Joubert Str Ladybrand  
PO Box 64 Ladybrand 9745  
Tel no (051) 924-0654 Fax no (051) 924-0020  
E-mail: mmsecretary@mantsopa.co.za/

*Corporate Services:*  
Tel no (051) 924 0654 Fax no (051) 924 0020

*Traffic Department*  
Tel no (051) 924-0654

*Head SAP:*  
Tel no (051) 923 4000 Tel/Fax no (051) 983-1302

##### **SUB STATIONS**

*Excelsior sub-station*  
PO Box 24 Excelsior 9760  
Tel no (051) 973-0015 Fax no (051) 973-0865

*Hobhouse sub-station*  
Mellet Str Hobhouse  
PO Box 5 Hobhouse 9740  
Tel no (051) 983-0013 Fax no (051) 983-0152

*Thaba Patchoa sub-station*  
177 Hobhouse Way Thaba Patchoa  
Tel no (051) 964-0012 Fax no (051) 964-0054

*Tweespruit sub-station*  
5 Peper Street Tweespruit  
PO Box 76 Tweespruit 9770  
Tel no (051) 963-0061 Fax no (051) 963-0110

#### **MASILONYANA MUNICIPALITY**

##### **AREAS UNDER CONTROL**

Theunissen, Brandford, Soutpan, Winburg, Verkeedevelei

##### **CONTACT INFORMATION**

Cnr Plenaar & Le Roux Streets Theunissen  
PO Box 8 Theunissen 9410  
Tel no (057) 733-0106 Fax no (057) 733-2417  
Email: info@masilonyana.co.za / info@masilo.co.za

##### **STATISTICS**

*Size of area:* 80 sq kms  
*Population:* 52 000

##### **SUB-STATIONS**

*Brandfort sub-station*  
Brand Str Brandfort  
PO Box 13 Brandfort 9400  
Tel no (051) 821-2222 Fax no (051) 821-1078

*Soutpan sub-station*  
Tel no (051) 831-1116/5 Fax no (051) 831-1116

*Verkeedevelei sub-station*  
Handel Str Verkeedevelei  
PO Box 13 Verkeedevelei 9401  
Tel/fax no (051) 841-1147

#### **STATISTICS**

*Size of area:* 6 sq kms  
*Population:* 4000  
*Winburg sub-station*  
Brand Str Winburg  
PO Box 26 Winburg 9420  
Tel no (051) 881-0003 Fax no (051) 881-0003

#### **STATISTICS**

*Size of area:* 8 sq kms  
*Population:* 36 862

#### **MATJHABENG MUNICIPALITY EMERGENCY SERVICES**

##### **AREAS UNDER CONTROL**

Welkom, Allanridge, Hennenman, Odendaalsrus, Ventersburg, Virginia, Thabong, Meloding, Phomolong, Mamahabane, Kutlwanong, Nyakallong

##### **CONTACT INFORMATION**

Volks Rd Doorn Welkom  
PO Box 485 Welkom 9460 / PO Box 708 Welkom 9460  
Tel no (057) 352- 6666 / 1840 Fax no (057) 352-4444  
Emergency no (057) 352 2222

*Social Services and PS&T:*  
Email: info@matjhabeng.co.za  
Tel no (057) 391 3312  
*Public Safety & Transport:*  
Tel no (057) 391 3226 Fax no 086-506-0984

*Fire Services:*  
Fax2email: 086 5360 549 / 086 511 5276

##### **STATISTICS**

*Size of area:* 5170 sq kms  
*Population:* 405 064  
*Value of area protecting:* R 994 891 900.00  
Fire stations: 6

##### **FIRE STATIONS/UNITS**

*Hennenman Unit*  
Church Str Hennenman  
Tel no (057) 573-2988

*Mmamahabane - Ventersburg unit*  
N1 Highway  
Tel no (057) 391 651-4031

*Odendaalsrus unit*  
Mark Str Odendaalsrus  
Tel no (057) 354-1111/391-8500

*Virginia unit*  
Market Str Virginia  
Tel no (emergency) (057) 212-5444 / 6826

*Welkom Unit*  
Volks Rd Welkom  
Tel no (057) 352-1840

*Phomolong Unit*  
Tel no (057) 573 1820 / 2988

#### **METSIMAHOLO MUNICIPALITY FIRE DEPARTMENT**

##### **AREAS UNDER CONTROL**

Sasolburg, Deneysville, Oranjeville

##### **CONTACT INFORMATION**

JG Strydom Road Sasolburg  
PO Box 60 Sasolburg 1947  
Tel no (016) 973 8864 / 016 976 0945  
Fax no (016) 976-2474/976-5205

*Municipal Management:*  
Tel no (016) 973-8314  
Fax no (016) 976 5205

*Fire Services:*  
Fax no (016) 976 2474 Tel no (016) 973-8796

##### **STATISTICS**

*Size of area:* 1717423 sq kms  
*Population:* ± 213486

#### **MOHOKARE MUNICIPALITY FIRE DEPARTMENT**

##### **AREAS UNDER CONTROL**

Zastron, Rouxville, Smithfield

##### **CONTACT INFORMATION**

*Zastron Office*  
Hoofd Str Zastron  
PO Box 20 Zastron 9950  
Tel no (051) 673-9600

*Fire/Traffic services:*  
Chief Fire/Traffic Officer:  
Tel no (051) 673 1503

##### **STATISTICS**

*Size of area:* 70 sq kms  
*Population:* 8 200  
*Fire stations:* 3

##### **FIRE STATIONS**

*Rouxville Fire Department*  
280 Church Str Rouxville PO Box 8 Rouxville 9958  
Tel no (051) 663-0366

##### **STATISTICS**

*Size of area:* 8 sq kms  
*Population:* 11 000

##### *Smithfield Fire Department*

Cnr Voortrekker & President Strs Smithfield  
Private Bag X02 Smithfield 9966  
Tel no (051) 683-1143

##### **STATISTICS**

*Traffic:* Tel no (051) 683 0349  
*Size of area:* 24 sq kms  
*Population:* 8 000

#### **MOQHAKA MUNICIPALITY EMERGENCY SERVICES**

##### **AREAS UNDER CONTROL**

Kroonstad, Steynsrus, Viljoenskroon

##### **CONTACT INFORMATION**

*Head Quarters Fire Brigade Services*  
Symonds Str Kroonstad  
PO Box 302 Kroonstad 9500  
Tel no (056) 216-9111 Fax no 086 523 7534 / 056 533 4585  
Emergency tel no (056) 216-9111 / 9110

*Municipal Management:*  
Tel no (056) 216-9104 Fax no (056) 216-9105

*Community & Social Services:*  
Tel no (056) 216 9333 Fax no (056) 216 9308

*Fire Services:*  
Tel no (056) 216 9222 Fax no 086 523 7534

##### **STATISTICS**

*Size of area:* 213 sq kms  
*Population:* 260 000

##### **ADMINISTRATIVE UNITS**

*Steynsrus Administrative Unit*  
Van Riebeeck Str  
PO Box 6 Steynsrus 9515

Tel no (056) 471-0006 Fax no (056) 471-0428

*Viljoenskroon Administrative Unit*  
Deneysen Str  
PO Box X02 Viljoenskroon 9520  
Tel: (056) 343-9400 Fax (056) 343-2505

#### **NALA LOCAL MUNICIPALITY**

##### **AREAS UNDER CONTROL**

Bothaville, Wesselsbron, Kgotsong, Monyakeng

##### **CONTACT INFORMATION**

Preller Str Bothaville Private Bag X15 Bothaville 9660  
Tel no (056) 514 9200  
Traffic Department: Tel no (056) 515-6711  
Public Safety: Tel no (056) 515 6711

##### **STATISTICS**

*Size of area:* 3000 sq kms  
*Population:* ± 90 000

##### **FIRE STATIONS**

*Wesselsbron fire station*  
PL Kotze Str Wesselsbron  
PO Box 6 Wesselsbron 9680  
Tel no (057) 899-1818 Tel no 071 600 2669

*Bothaville fire station*  
Tel no (056) 515-6711

#### **NGWATHE MUNICIPALITY PROTECTION SERVICES**

##### **AREAS UNDER CONTROL**

Parys, Vredefort, Koppies, Edenville, Heilbron

##### **CONTACT INFORMATION**

Cnr Phillip & Van der Merwe str, Parys  
PO Box 359 Parys 9585  
Tel no (056) 811-5834 Cell no 082 704 3252  
Fax no (056) 811-2077

*Municipal Management:*  
Tel no (056) 816 2700

##### **STATISTICS**

*Size of area:* 800 sq kms  
*Population:* ± 150 000  
*Fire stations:* 2 (operational); 2 (planned)

##### **FIRE STATIONS**

*Edenville Fire Station*  
Tel no (058) 631 0015 Fax no (056) 631 0019

*Heilbron Fire Station*  
Laer Str Heilbron  
PO Box 45 Heilbron 9650  
Tel no (058) 852-2014 Fax no (058) 522-1764

*Koppies*  
Tel no (056) 777 1819 Fax no (056) 777 2745

*Vredefort Fire Station*  
Kerk Str Vredefort  
PO Box 16 Vredefort 9595  
Tel no (056) 931-0012 / (056) 811-5834  
Fax no (056) 931-0082

#### **NKETOANA MUNICIPALITY FIRE DEPARTMENT**

##### **AREAS UNDER CONTROL**

Reitz, Petrus Steyn, Arlington, Lindley

##### **CONTACT INFORMATION**

Cnr Church & Voortrekker St, Reitz  
PO Box 26 Reitz 9810  
Tel no (058) 863-2811  
Fax no (058) 863 2523

## STATISTICS

Population: 35 000

## FIRE STATIONS

### Arlington Fire Station

Tel / Fax no (058) 453-0034 Fax no (058) 453 0733

### Lindley Fire Station

Tel no (058) 463-0004

Fax no (058) 463-0182

### Petrus Steyn Fire Station

Church Str Petrys Steyn

PO Box 12 Petrus Steyn 9640

Tel no (058) 871-3131

Fax no (058) 871-3703

### Reitz Fire Station

PO Box 26 Reitz 9810

Tel no (058) 863-2811

Fax no (058) 863 2523

## PHUMELELA MUNICIPALITY FIRE DEPARTMENT

### AREAS UNDER CONTROL

Vrede, Memel, Warden

### CONTACT INFORMATION

52 Kuhn Str (C/O Kuhn & Prinsloo) Vrede

Private Bag X5 Vrede 9835

Tel no (058) 913-8300

Fax no (058) 913-2317/3601

### Community Services:

Tel no (058) 913-8300

Fax no (058) 913-2317

### FIRE STATIONS

#### Memel Fire Station

Voortrekker Str Memel

PO Box 24 Memel 2970

Tel no (058) 924-0078/ 0000

Fax no (058) 924-0000

#### Warden Fire Station

C/O Pietretief and Agter Ln, Warden, 9870

Tel no 058 643 0005 / 0099

Fax no 058 643 0310

Cell no 076 430 2382

## SETSOTO MUNICIPALITY FIRE SERVICES

### AREAS UNDER CONTROL

Ficksburg, Senekal

### CONTACT INFORMATION

27 Voortrekker Str Ficksburg

PO Box 116 Ficksburg 9730

Tel no (051) 933-9300

Fax no (051) 933-9309

### Municipal Management:

Tel no (051) 933-9302

Fax no (051) 933-9363

### Corporate Services:

Tel no (051) 933-9303

Fax no 086 408 0005

Email: directorcorporate@setsoto.co.za

### Administration:

Tel no (051) 933-9324

Email: admin@setsoto.co.za

### Skills Development:

Tel no (051) 933-9447

Email: sdf@setsoto.co.za

### Occupational Health & Safety:

Tel no (051) 933-9328

### Protection Services:

Tel no (051) 933-9336

Cell no 082 335 2414

### Safety & Security Officer:

Tel no (051) 933-9381

### Disaster/Traffic:

Tel no (051) 933-9326

Email: disaster@setsoto.co.za

### Fire Prevention:

Cell no 073 791 5611

## STATISTICS

Population: ± 124 000

## FIRE STATIONS

### Ficksburg Station

Voortrekker Str Ficksburg

PO Box 116 Ficksburg 9730

Tel no (051) 933-9300

Fax no (051) 933-9309

### Senekal Station

48 Van Riebeeck Str Senekal

PO Box 20 Senekal 9600

Tel no (058) 481-2142

Fax no (058) 481-5154

## TOKOLOGO LOCAL MUNICIPALITY FIRE SERVICES

### AREAS UNDER CONTROL

Boshoff, Hertzogville, Dealesville

### CONTACT INFORMATION

Cnr Market Square & Voortrekker Str, Boshoff

Private Bag X46 Boshoff 8340

Tel no (053) 0014 / 0360 / 0052

Email: info@tokologo-municipality.co.za

## STATISTICS

Size of area: 35 sq kms

Population: 20 000

## TSWELOPELE LOCAL MUNICIPALITY

### AREAS UNDER CONTROL

Bullfontein, Hoopstad, Phahameng, Tikwana

### CONTACT INFORMATION

Civic Centre Bosman Str Bullfontein

PO Box 3 Bullfontein 9670

Tel no (051) 853-1111

Fax no (051) 853-1332

## STATISTICS

Size of area: 84 sq kms

Population: Bullfontein: ± 1800 - Phahameng: ± 35000 -

Hoopstad: ± 1500 - Tikwana: ± 24000

## FIRE STATIONS

### Hoopstad Fire Station

C/O School and Buiten Street Hoopstad

PO Box 39 Hoopstad 9479

Tel no (053) 444-1897

Fax no (051) 444 1003

Cell no 082 574 4942

# GAUTENG

## EKURHULENI METROPOLITAN MUNICIPALITY:

### DEPARTMENT: DISASTER AND EMERGENCY SERVICES

### AREAS UNDER CONTROL

Alberton, Bedfordview, Benoni, Boksburg, Brakpan, Daveyton, Duduza, Edenvale, Etwatwa, Tsakane, Farrarmere, Germiston, Hlahatsi, Kwa-Thema, Selection Park, Kempton Park, Leon Ferreira, Nigel, Olifantsfontein, Palmridge, Primrose, Rynfield, Zonkiszwe, Springs, Tembisa, Thokoza, Vosloorus, Wadeville

### CONTACT INFORMATION

Emergency Services Division

3 Hawley Rd Bedfordview

PO Box 145 Germiston 1400

Emergency Communication Centre: 10177

### Divisional Head: Emergency Services:

Tel no (011) 999 0187

Fax No 086 628 2279

Secretary: Tel no (011) 999 0191 Fax no 086 627 5811

Head of Department: Disaster and Emergency Management Services:

Tel no (011) 999 1735

Executive Manager: Auxiliary Services & Training:

Tel no (011) 999 1477

Executive Manager: Fire Safety Services:

Tel no (011) 999 0193

Manager of Training Services:

Tel no (011) 999 0187

## OPERATIONS

### Alberton Fire Station

Tel no (011) 999-2527

### Bedfordview Fire Station

Tel no 011 999 2004

### Benoni Central Fire Station

Tel no (011) 422-2509

### Boksburg Central Fire Station

Tel no (011) 999 5475

### Brakpan Central Fire Station

Tel no 011 999-7728

Fax no (011) 741-2233

### Daveyton Fire Station

Tel no (011) 999-6405

### Duduza Fire Station

Tel no (011) 999 9319

### Edenvale Fire Station

Tel no (011) 999-2987

Fax no (011) 452-9470

### Etwatwa Fire Station

Tel no (011) 999 7217

### Tsakane Fire Station

Tel no (011) 999 8039

### Farrarmere Fire Station

Tel no (011) 999-8023

### Germiston Central Fire Station

Tel no (011) 999-0629

### Hlahatsi Fire Station

Tel no (011) 999 1369

### Kwa-Thema Fire Station

Tel no (011) 999 8742

### Selection Park Fire Station

Tel no (011) 999 8557

### Kempton Park Fire Station

Tel no (011) 999 4920

Fax no (011) 970-1428

### Leon Ferreira Fire Station

Tel no ((011) 999-9215

Fax no (011) 894-7330

### Nigel Fire Station

Tel no (011) 999 3892

Fax no (011)814-8854

### Olifantsfontein Fire Station

Tel no (011) 999 4684

### Palmridge Fire Station

Tel no (011) 999-2986

### Primrose Fire Station

Tel no (011) 999 3795

### Rynfield Fire Station

Tel no (011) 999 6892

### Zonkiszwe Fire Station

Tel no: 011-999-1036 / 5190

### Springs Fire Station

Tel no (011) 999-6405

### Tembisa Fire Station

Tel no (011) 999 4385

### Thokoza Fire Station

Tel no Tel no (011) 999-2795

### Vosloorus Fire Station

Tel no (011) 999 5818/ 999-5067

### Wadeville Fire Station

Tel no (011) 999 1290

### Commercial Fire Station

Tel no 011 999 4527

## PROACTIVE AND LOGISTICS

Codes Eastern Region (Fire Safety)

Tel no (011) 999-8099

Codes Northern Region (Fire Safety)

Tel/Fax no (011) 999-3794

Codes Southern Region (Fire Safety)

Tel/Fax no (011) 999-1532

### Emergency Planning

Tel no (011) 999-5491/5967

### Logistics: Northern Region

Tel no (011) 999 6018

Fax no (011) 894 7330

### Logistics: Southern Region

Tel no (011) 999-2534

### Logistics: Eastern Region

Tel no (011) 999-8325

### Training Academy

Tel no (011) 999-5811/5790

### Mess Facilities

Tel no (011) 999-6029

### Emergency Communication Centre:

10177 / (011) 458 0911

## EMFULENI MUNICIPALITY FIRE AND EMERGENCY SERVICES

### AREAS UNDER CONTROL

Vanderbijlpark, Vereeniging, Sebokeng, Evaton



**CONTACT INFORMATION**

*Head Office:*  
PO Box 3 Vanderbijlpark 1900  
Tel no (016) 430 1818/16 / 1803  
Fax no (016) 455-5389  
Fax2email: 086-269 4929 / (016) 455-5389  
*Fire Services: Operations:*  
Tel no (016) 430-1804  
Fax2email: 086-555-5332

*Admin & Logistics Fire Safety and Disaster Management:*  
Tel no (016) 430-1805  
Fax2email: 086-269 4211

*Disaster Management & FPA:*  
Tel no (016) 430-1812  
Fax2email: 086-269 4152

**REGIONS AND FIRE STATIONS****Region 1 - Vereeniging Fire Station**

De Villiers Ave Vereeniging  
Tel no (016) 430-1807  
Fax (016) 455-5389  
Fax2email: 086 555 5577

**Region 2 - Vanderbijlpark Fire Station**

Cnr Frikkie Meyer Blvd & Westinghouse Blvd Vanderbijlpark  
PO Box 3 Vanderbijlpark 1900  
Tel no (016) 430 1856  
Fax no (016) 950-5271  
Fax2email: 086 269 4368

**Region 3 - Evaton Fire Station**

Cnr Golden Highway & Easton Road, Evaton

**Region 4 - Sebokeng Fire Station**

Moshoeshoe Street, Sebokeng  
Tel no (016) 430 1837 / (016) 592 9300  
Fax2Email: 086 269 4342

**STATISTICS**

*Population:* 721 663 (Census 2011)

**CITY OF JOHANNESBURG MUNICIPALITY EMERGENCY MANAGEMENT SERVICES****AREAS UNDER CONTROL**

Johannesburg, Midrand, Randburg, Sandton, Roodepoort,

**CONTACT INFORMATION**

*Head Office*  
Public Safety Headquarters  
195 Main Road Martindale 2092  
Tel no (011) 758-9100

**Florida Park Fire Station**

Ontdekkers Cnr Golf Club Terrace, Florida Park  
Tel no (011) 758-5208  
Fax no (011) 758-5253

Emergency call taking centre: (011) 375-6068 / (011) 375-5911

Emergency calls: Fire & Medical: 10177

**Head of EMS:**

Tel no (011) 222-8066

**Executive Secretary:**

Tel no (011) 222 8067

**Acting Deputy Director:**

Tel no (011) 222 8047

**Senior Secretary:**

Tel no (011) 222 8047

**Strategic Support:**

Tel no (011) 222-8044

**Special Projects:**

Tel no (011) 222-8065

**Corporate Services:**

Tel no (011) 222-8060

**Operations:**

Tel no (011) 222 8067 / 68 / 8047

**Disaster Management:**

Tel no (011) 222 8015/86

**Pro-Active Services/Fire Safety & PIER:**

Tel no 011 222 8087 Fax no 086 636 2080

**Training Academy:**

Tel no (011) 222 8104 Fax no (011) 837 0067

**Brixton Training:**

Tel no (011) 222 8104 Cell no 083 383 8787

Fax no (011) 837-4172

**Repairs & Maintenance:**

Tel no (011) 624 3014

Fax no (011) 614 1463

**Fleet admin:**

Tel no (011)758 5233 / 5236

Fax no (011) 381 9233 / 5228

**Medical Training:**

Tel no (011) 758 5209

Fax no (011) 758 5211

**Divisional Chief PIER:**

Tel no (011) 222 8023

**Divisional Chief Disaster management:**

Tel no (011) 222 8015

Fax no (011) 758 9179

**OPERATIONS DISTRICTS****District 1 - Midrand, Lonehill, Diepsloot, Ivory Park, Cosmo City**

Tel no (011) 847 4610

Fax no (011) 847 4623

**Midrand Fire Station**

Tel no (011) 847-4614

**Lonehill Fire Station**

Tel no (011) 465-5792

**Diepsloot Fire Station**

Tel no (011) 674 0130

**Ivory Park Fire Station**

Tel no (011) 204 0693

**Cosmo City Fire Station**

Tel no (011) 875 2175

**District 2 - Sandton, Modderfontein, Alexandra, Northview, Rosebank**

Tel no (011) 222 8272

**Sandton Fire Station**

Tel no (011) 222 8271

**Alexandra Fire Station**

Tel no (011) 346 1378

**Northview Fire Station**

Tel no (011) 786-3038

**Modderfontein Fire Station**

Tel no (011) 608-2038

**Rosebank Fire Station**

Tel no (011) 788-5000/5219

**District 3 - Fairview, Malvern, Central, Brixton, Berea**

Tel no (011) 222 8123

Fax no (011) 614 8891

**Brixton Fire Station**

Tel no (011) 222 8123

**Berea Fire Station**

Tel no (011) 642-4669

**Malvern Fire Station**

Tel no (011)614-1945

**Central Fire Station**

Tel no (011) 331-3141/2

**Fairview Fire Station**

Tel no (011) 618 4085

**District 4 - Eldorado Park, Kibler Park, Turffontein, Orange Farm, Lawley, Rietfontein**

Tel no (011) 222 8219

Fax no (011) 342-4439

**Turffontein Fire Station**

Tel no (011) 222 8102

**Kibler Park Fire Station**

Tel no (011) 674-0130

**Orange Farm Fire Station**

Tel no (011) 211 6000

**Lawley Fire Station**

Tel no (011) 618 9019

**Rietfontein Fire Station**

Tel no (011) 026 9288

**District 5 - abulani, Diepkloof, Dobsonville, Eldorado**

Tel no (011) 222 8198

Fax no (011) 763 1260

**Diepkloof Fire Station**

Tel no (011) 985-9738

**Dobsonville Fire Station**

Tel no (011) 989-2931/2

**Eldorado Park Fire Station**

Tel no (011) 342-3751

**Jabulani Fire Station**

Tel no (011) 222 8197

**District 6 - Randburg, Roosevelt Park, Hodgson, Huntershill, Florida Park**

Tel no (011) 789 1351

**Randburg Fire Station**

Tel no (011) 789-1351

**Roosevelt Park Fire Station**

Tel no (011) 782-4642/3

**Hodgson Street Fire Station**

Tel no (011) 763-1111

**Hunters Hill Fire Station**

Tel no (011) 789 1351

**Florida Park Fire Station**

Tel no (011) 794 2666

**Fire and Hazmat Training Academy**

Cell no 083 400 3834

**LESEDI MUNICIPALITY FIRE AND RESCUE SERVICES****AREAS UNDER CONTROL**

Heidelberg, Devon, Vischuil, Spaarwater, Driemanskaap, Endicott, Blesbokspruit, Bloekomspruit, Jameson Park, iMpumelelo, Kwazandisele, Kwazenzele

**CONTACT INFORMATION**

1 HF Verwoerd Street, Civic Centre Building, Heidelberg, Gauteng

PO Box 201 Heidelberg 1441

Switchboard: (016) 330 0400

Emergency tel no 082 564 6817

**Fire Services:**

Tel no (016) 340 0400

**STATISTICS**

*Size of area:* 1550 km<sup>2</sup>

*Population:* 111 000

**CITY OF TSHWANE METROPOLITAN MUNICIPALITY  
TSHWANE EMERGENCY SERVICES DEPARTMENT****AREAS UNDER CONTROL**

Pretoria, Rosslyn, Centurion, Silverton, Wonderboom, Bronkhorstspuit, Philip Nel Park, Hatfield, Garankuwa, Erasmuskloof, Heuweloord, Hammanskraal, Rayton, Innesdale, Mabopane, Saulsville, Hazelwood, Soshanguve, Ekangala, Mamelodi, Hammanskraal Pretoria North

**CONTACT INFORMATION**

133 Government and Beckett Street

PO Box 440 Pretoria 0001

Tel no (emergency) (012) 310-6300 / 310-6400,

Tel no (admin) (012) 358-2151 Fax no (012) 358-2308

Email: [emergencyservices@tshwane.gov.za](mailto:emergencyservices@tshwane.gov.za)

*Public Information & Media Liaison Officer:* Tel no (012) 358 6291

**STATISTICS**

*Size of area:* 6368 sq. kms

*Population:* 3 350 000

**FIRE STATIONS****Station 1:**

Cnr Bosman and Minnaar Sts Central

**Station 2:**

3 Piet Rautenbach St Rosslyn

**Station 3:**

246 Basden Ave Centurion

**Station 4:**

Fred Davey Lane Silverton

**Station 5:**

Cnr Lavender Rd & Borage Sts Wonderboom

**Station 6:**

Lanham Street Extension Bronkhorstspuit

**Station 7:**

Cnr Morkel & Trans Oranje Rds Philip Nel Park

**Station 8:**

122 Linvelt Road, Wonderboom Airport

**Station 9:**

979 Park Street Hatfield

**Station 10:**

South Street Zone 15 Garankuwa

**Station 11:**

Cnr Tsitsa and Lois Sts Erasmuskloof

**Station 12:**

24 Wildeperske Avenue, Heuweloord

**Station 13:**

1st Street Hammanskraal

**Station 14:**

C/O Oakley & Montrose Streets, Rayton

**Station 15:**

Cnr Ben Swart & Fourteenth Ave Innesdale

**Station 16:**

Central Business district Mabopane

**Station 17:**

Marivate St Saulsville

**Station 18:**

33 Pinaster St Hazelwood

**Station 19:**

Soutpan Road Soshanguve

**Station 20:**

Stand 452 Dark City, Ekangala

**Station 21:**

Serapeng Avenue, Mamelodi

**Station 23:**

Satellite Hammanskraal

**Station 24:**

Heinrich Avenue, Pretoria North

**WESTRAND DISTRICT MUNICIPALITY****AREAS UNDER CONTROL**

Mogale City, Westonaria, Randfontein, Merafong City

**CONTACT INFORMATION***Directorate Public Safety*

Cnr 6th & Park Rd Randfontein  
Private Bag X033 Randfontein 1760  
Tel no (011) 411-5000  
Fax no (011) 412-3663  
Emergencies: 107 / (011) 951 3000  
Tel no (011) 411-5205  
Fax no (011) 411-5260

*Public Safety & Regional Support:*  
Tel no (011) 411-5203/5281

*Disaster Management and Community Safety:*  
Tel no (011 ) 951-3000 / 3026

*Emergency Services:*  
Tel no (011) 411-5099

*Fire Risk Management:*  
Tel no (011) 411-5284

**FIRE STATIONS / DISTRICTS***Mogale Emergency Services*

*Areas under control:* Magaliesburg; Muldersdrift; Kagiso, Munsiville; Azaadville. Magalies & district management areas  
Cnr Commissioner & Paardekraal Street Krugersdorp  
PO Box 1703 Krugersdorp 1740  
Tel no (011) 665-2644  
Fax no (011) 665-2645

*Size of area protecting:* 1320 sq kms

*Fochville Emergency Services*

*Areas under control:* Fochville including Wedela  
129 Kerk Street Fochville  
Tel no (018) 771 6023 / (018) 771 5506  
Fax no (018) 771 6025  
*Size of area protecting:* 783.22 sq kms

*Carletonville Emergency Services*

*Areas under control:* Carletonville including Khutsong  
Cnr Onyx & Annan Road  
PO Box 6192 Oberholzer 2502  
Tel no (018) 786 2223/4  
Fax no (018) 786 2227

**STATISTICS**

*Size of area protecting:* 1631.7 sq kms

**Westonaria Emergency Services**

*Areas under control:* Westonaria including Bekkersdal  
Cnr Malan & Doveton Strs  
Tel no (011) 753-3925  
Fax no (011) 753-4035

**STATISTICS**

*Size of area:* 617 sq kms

**Randfontein Emergency Services**

Retief Str Randfontein  
Tel no (011) 693-2234  
Fax No (011) 693-1031

**STATISTICS**

*Size of area protecting:* 442sq kms

**EMADLANGENI PROTECTION SERVICES****AREAS UNDER CONTROL**

Utrecht

**CONTACT INFORMATION**

34 Voor Str Utrecht  
PO Box 11 Utrecht 2980  
Tel no (034) 331-3041 / 4180 Fax no (034) 331-3040 / 4181

**ETHEKWINI MUNICIPALITY FIRE AND EMERGENCY SERVICES****AREAS UNDER CONTROL**

*Central region:* Durban, Congella, Jacobs, Chatsworth  
*Western region:* Pinetown, Queensburgh, Westville, Pinetown South, Gillitts, Hammarsdale, Cato Ridge  
*Southern region:* Amanzimtoti, Prospecton, Moberni, Umlazi, Umkomaas,  
*Northern region:* Durban North, Phoenix, Umhlanga Rocks, Ntuzuma, Tongaat

**CONTACT INFORMATION**

15 - 18 ML Sultan Rd Durban  
PO Box 625 Durban 4000  
Emergency no (031) 361-0000  
Tel no (031) 308-7000 / (031) 322 8750  
E-mail: Fire@durban.gov.za  
Website: www.durbanfire.gov.za

*Fire Officer (Head FESU):*

Tel no (031) 308 7000/ 7002/ 7104 / 322 5725  
Fax no (031) 309-6088

*Management Operations:*

Tel: 031 322 5733 / 031 308 7003

*Management Fire Safety:*

Tel: 031 322 2900

*Management Support Services:*

Tel no (031) 322 0910

*Management Training:*

Tel no (031) 322 0911 Fax no (031) 309 1050

**REGIONS:****Central Region**

*Regional Commander:*  
Tel no (031) 308-7000 / (031) 322 5728

*Fire stations:* Central, Congella, Jacobs, Chatsworth

**Western Region**

*Regional Commander:*  
Tel no (031) 322 2966  
*Fire stations:* Pinetown, Queensburgh, Westville, Pinetown South, Gillitts, Hammarsdale, Cato Ridge

**Southern Region**

*Regional Commander:*  
Tel no (031) 903-9000 / 21 (031) 322 8836  
Fax no (031) 903-3172

*Fire stations:* Amanzimtoti, Prospecton, Moberni, Umlazi, Umkomaas

**Northern Region**

*Regional Commander:*  
Tel no (031) 322 0970 / (031) 584-0400/1/2/3  
*Fire Stations:* Durban North, Phoenix, Umhlanga Rocks, Ntuzuma, Tongaat

**STATISTICS**

*Size of area:* 2297 sq kms

*Population:* 3 853 278

*Value of area protecting:* ± R544,803,249,761

**INKOSI LANGA LIBALELE LOCAL MUNICIPALITY****AREAS UNDER CONTROL**

Estcourt, Weenen

**CONTACT INFORMATION***Head Office:*

Victorious Str, Civic Centre Bulding, Estcourt  
Corner of Elisabeth and Subway Rd  
PO Box 15 Estcourt 3310  
Tel no (036) 342 7800 Fax no (036) 352 5829  
Emergency no (036) 352-6464 / (036)-342 7871  
Email fire@ilm.gov.za

*Municipal Management:*

(Victoria Str, Estcourt)  
Tel no (036) 342-7800 Fax no (036) 353 6661  
Email: municipalmanager@ilm.gov.za

*Traffic:*

Albert Str Estcourt  
Tel no (036) 342 7800 Fax no (036) 352-5237

**STATISTICS**

*Size of area:* 2130 sq kms

*Population:* ± 71 446

**KOKSTAD, GREATER MUNICIPALITY COMMUNITY SAFETY SERVICES****CONTACT INFORMATION**

75 Hope Str Kokstad  
PO Box 8 Kokstad 4700  
Tel no (039) 797-6600 Fax no (039) 727-3676  
Email: Info@kokstad.gov.za

*Fire Disaster Management:*

Tel no (039) 797 6659 Fax: (039) 727 5501

*Traffic & Licencing:*

Tel no (039) 797 6713

**STATISTICS**

*Size of area:* 505 sq kms

**KWADUKUZA MUNICIPALITY FIRE & EMERGENCY SERVICES****AREAS UNDER CONTROL**

Dolphin Coast, Stanger, Zinkwazi, KwaDukuza

**CONTACT INFORMATION***Head Office*

14 Chief Albert Luthuli Str, KwaDukuza  
PO Box 72 KwaDukuza 4450  
Tel no (032) 437 5515 / 072 426 8208

*Fire services:*

2 Industria Crescent, Lavoipierre Building, KwaDukuza  
Tel no (032) 437 5160 / 072 400 8889

*KwaDukuza Fire Station*

1 Gledhow Mill Road  
Tel no (032) 437-5160 / 946 8039 / 072 404 0398

*Ballito Drive, Ballito Fire Station*

PO Box 5 Ballito, 4420  
Tel no. (032) 437 5080 / 5570 / 078 380 3129

*Emergency Call Centre*

Tel no: (032) 437 5570  
Emergency line: (032) 946 2711

**STATISTICS**

*Size of area:* 630 sq kms; district 3260 sq kms

*Population:* Out season 220 000 / In season 280 000 / District 570 000

*Fire stations:* 2

# KWAZULU NATAL

**ABAQULUSI MUNICIPALITY****AREAS UNDER CONTROL**

Vryheid

**CONTACT INFORMATION**

Cnr Mark & High Sts, Vryheid  
PO Box 57 Vryheid 3100  
Tel no (034) 982 2133  
Fax no (034) 980 9637 / 080 020 0102  
Email: records@abaqulusi.gov.za / information@abaqulusi.gov.za

*Municipal Management:*

*Tel no (034) 328 7600*

*Fire Brigade:*

Tel no (034) 328 4700

*Public Safety:*

Tel no (034) 982-2276

*Community Social and Corporate Services:*

Tel no (034) 982-2227

*Environment Services:*

Tel no (034) 980-7033

*Disaster Management:*

Tel no (034) 982-2133

**STATISTICS**

*Size of area:* 4185 sq kms

*Population:* 224 546

*Value of area protecting:* R282 113 770

**ALFRED DUMA LOCAL MUNICIPALITY: DEPARTMENT PUBLIC SAFETY AND EMERGENCY SERVICES****AREAS UNDER CONTROL**

Ladysmith

**CONTACT INFORMATION**

422 Murchison Str Ladysmith  
PO Box 29 Ladysmith 3370  
Tel no (036) 631-1777  
Fax no (036) 631-1029

**STATISTICS**

*Size of area:* 4010.13 sq kms

*Population:* 339 777

**EDUMBE MUNICIPALITY PROTECTION SERVICES****AREAS UNDER CONTROL**

Paulpietersburg

**CONTACT INFORMATION**

10 Hoog Str Paulpietersburg  
Private Bag X308 Paulpietersburg 3180  
Tel no (034) 995-1650  
Fax no (034) 995-1192  
Cell no 082 628 0716  
Emergency number tollfree: 0800 261 261  
Email: info@edumbe.gov.za/ records@edumbe.gov.za

**STATISTICS**

*Size of area:* 2800 sq kms

*Population:* 82 207

**MPOFANA MUNICIPALITY TRAFFIC & SAFETY****AREAS UNDER CONTROL**

Mooi River

**CONTACT INFORMATION**

R103 Main Road Mooi River Testing Grounds  
PO Box 47 Mooi River 3300  
Tel no (033) 263-7750 / 263 1212 / 263 2862  
Fax no (033) 263-2024 / 086 561 3024  
Email: info@mpofana.gov.za

**STATISTICS**

Size of area: ± 20 sq km  
Population: 4000

**MSUNDUZI MUNICIPALITY FIRE DEPARTMENT****AREAS UNDER CONTROL**

Pietermaritzburg

**CONTACT INFORMATION**

324 Pietermaritz Str Pietermaritzburg 3201  
PO Box 1490 Pietermaritzburg 3200  
Tel no (033) 392-3700 Fax no (033) 392-2509  
Tel no (emergency) (033) 845-5911 / 0800 033911  
Fire & Rescue Services: (033) 845-5900/60  
Emergencies: (033) 845-5911 / 0800 033 911  
Disaster Management: (033) 392-2032 / (033) 845-5960  
Public Safety: Tel no (033) 392-2900  
Communications Officer: Tel no (033) 392 3735

**STATISTICS**

Size of area: 11 311 sq kms  
Population: 800 000

**MTUBATUBA FIRE DEPARTMENT****CONTACT INFORMATION**

Lot 105, INkosi Mtubatuba Rd, Mtubatuba  
PO Box 52 Mtubatuba 3935  
Tel no (035) 550-0069 Fax no (035) 550-0060  
Community Services:  
Tel no (035) 550 0069 Fax no (035) 550 0060

**Fire and Rescue:**

Tel no (035) 573 1080

**Protection Services:**

Tel no (035) 550 0168 Fax no (035) 550 4257

**STATISTICS**

Size of area: ± 250 sq kms  
Population: 175 425

**NEWCASTLE LOCAL MUNICIPALITY (KZ252).  
DEPARTMENT OF COMMUNITY SERVICES. COMMUNITY  
SAFETY DIRECTORATE****Fire & Disaster Management Services**

Section: Newcastle Fire &amp; Disaster Management

**CONTACT INFORMATION**

3 Albert Wessels Drive, Newcastle  
Private Bag X6621 Newcastle 2940  
Tel no: (034) 328 4700  
Emergency no: (034) 312 1222 / 3

**Municipal Management:**

Tel no (034) 328-7600

Email: mm@newcastle.gov.za

**STATISTICS**

Size of area: 1 894 sq kms  
Population: 363,236

**OKHAHLAMBA LOCAL MUNICIPALITY FIRE  
DEPARTMENT****AREAS UNDER CONTROL**Bergville, Winterton, Cathkin Park, Van Reenen, Geluksberg,  
Central Drakensberg and Northern Drakensberg**CONTACT INFORMATION**

1 Golf St, Bergville  
PO Box 71 Bergville 3350  
Tel no (036) 448-8000  
Emergency Call Centre no: 0800 111 455 (24 hrs)  
Fax no (036) 448-1986

**Municipal Management:**

Tel no (036) 448 8000

**Protection Services:**

Tel no (036) 448 1092

**STATISTICS**

Size of area: ± 2980 sq kms  
Population: ± 123 106

**SUB STATIONS****Winterton substation**

Church Str Winterton

PO Box 242 Winterton 3340

Tel no (036) 488-1620 Fax no (036) 488-1194

**RAY NKONYENI MUNICIPALITY FIRE DEPARTMENT &  
DISASTER SERVICES****AREAS UNDER CONTROL**Hibberdene, Port Shepstone, Margate, Impenjati/Southbroom,  
Umtumvuna/Port Edward, Margate Airport, Ezinqoleni**CONTACT INFORMATION**

Allesund Rd Oslo Beach Port Shepstone

PO Box 5 Port Shepstone 4240

Tel no (039) 688-2000 Fax no (039) 688-2101

**Fire services:**

Tel no (039) 688-2095 Fax no (039) 688-2101

**STATISTICS**

Size of area: 1200 sq kms  
Population: 460000

**Sub Stations: 3****Airport: CAT 4****UBUHLEBEZWE MUNICIPALITY FIRE DEPARTMENT****AREAS UNDER CONTROL**

iXOPO Fire Department

**CONTACT INFORMATION**

29 Margaret Str, Ixopo

PO Box 132 Ixopo 3276

Tel no (039) 834-7700 Fax no (039) 834-1168

Cell no 082 532 4558

Email: admin@ubuhlebezwe.gov.za

**Municipal Management:**

Tel no (039) 834 7700

Email: mm@ubuhlebezwe.gov.za

**Disaster Management and Fire:**

Tel no (039) 834 2211

**Occupational Health and Safety Officer:**

Tel no (039) 834 7700

**STATISTICS**

Size of area: 1604 sq kms  
Population: 101691

**UMDONI DISASTER MANAGEMENT FIRE & RESCUE****AREAS UNDER CONTROL**

Scottburgh

**CONTACT INFORMATION**

Cnr Williamson & Braamfischer Str, Scottburgh  
PO Box 19 Scottburgh 4180  
Tel no (039) 976-1202 Fax no (039) 976-2194  
Call Centre: (039) 974-1061

**Municipal Management:**

Email: mmoffice@umdoni.gov.za

**Disaster Management Fire & Rescue:**

Tel no (039) 974-6200 Fax no 039 974 1130

**Communications:**

E-mail: communications@umdoni.gov.za

**STATISTICS**

Size of area: 234 sq kms

Population: 90 800

Fire stations:1

**UMHLATHUZE, CITY OF FIRE AND RESCUE SERVICES****AREAS UNDER CONTROL**Richards Bay, Empangeni, eSikhaleni / Vulindlela, Nseleni,  
Ngwelezane, Felixton, Ntambanana and 4 x Traditional authority  
areas**CONTACT INFORMATION**

10 Duralumin Duct, Alton Richards Bay, 3900

Private Bag X1004 Richards Bay 3900

Tel no (035) 907 5722 / 3

Emergency no (035) 797-3911

**EMRS (Emergency Medical Rescue Services)**

Tel no 10177 / (035) 787-6000/1/2/3/4 (035) 902 4777

**Netcare Office:**

Tel no: 0800 333 444

**SAPS Control room:**

Tel no: 10111 / (035) 9012475

**Traffic Control Room:**

Tel no: (035) 907 5760/1

**RTI (Road Traffic Inspectorate):**

Tel no (035) 7871464/5

**Municipal Management:**

Tel no (035) 907-5100

**Community Services:**

Tel No (035) 907-5167

**Head of Section Public Health and Safety:**

Tel no (035) 907-5713

**Management: Fire Services:**

Tel no (035) 907-5724 / 5731

**Disaster Management:**

Tel no (035) 907-5728

**Public Safety and Security:**

Tel no (035) 907-5663

**Traffic Officer:**

Tel no (035) 907-5613

**STATISTICS**

Size of area: 795 sq kms

Population: 334 459

Fire stations:5

**Main Fire Stations:** Alton, Richards Bay**Sub-Stations:** Empangeni, eSikhaleni/Vulindlela, Nseleni and  
Ntambanana**Airport Fire Houses:** 1**UMLALAZI MUNICIPALITY PROTECTION SERVICES****AREAS UNDER CONTROL**

Eshowe, Mtunzini, Gingindlovu

**CONTACT INFORMATION****Head Office:** Hutchinson Rd Eshowe**Protection Services:**

Butcher Str Eshowe

PO Box 37 Eshowe 3815

Tel no (035) 473 3300 / 3474 Fax no (035) 474 2909

**Emergency Services:**

Tel no (035) 474 2909

**Gingindlovu:**

Tel no (035) 473 3470

**Mtunzini:**

Tel no (035) 473 3460

**Municipal Management:**

Email: mm@umlalazi.org.za

Tel no (035) 473-3337

**Corporate Services:**

Tel no (035) 473-3315

**Community Services:**

Tel no (035) 473-3407

**Protection Services:**

Tel no (035) 473 3425

**STATISTICS**

Fire stations: 3

**UMNGENI LOCAL MUNICIPALITY****AREAS UNDER CONTROL**

Howick

**CONTACT INFORMATION**

Cnr Somme &amp; Dicks Str Howick

PO Box 5 Howick 3290

Tel no (033) 239 9284 Fax no (033) 330-4183

Control room tel no (033) 239-9244

**Municipal Management:**

Tel no (033) 239 8311 / 9266 Fax no (033) 330-4183

**Communications:**

Tel no (033) 239 9284

Cell no 073 541 2267

**Disaster Management Services:**

Tel no (033) 339 9252

Cell no 083 537 2048 / 079 874 4974

**STATISTICS**

Size of area: ± 300 sq kms

Population: 100 000

**UMUZIWABANTU MUNICIPALITY****AREAS UNDER CONTROL**

Harding, Nqabeni to Ingeli

**CONTACT INFORMATION**

Murchison Str

Private Bag X 1023 Harding 4680

Tel no (039) 433-3590 Fax no (039) 433-1208

Emergency Fire: 083 301 2528 / 083 499 2220 / 073 322 8043

**Fire and Traffic Services:**

Tel no (039) 433 1849

## UMVOTI MUNICIPALITY

### **AREAS UNDER CONTROL**

Greytown

### **CONTACT INFORMATION**

41 Bell Str Greytown  
PO Box 71 Greytown 3250  
Tel no (033) 413-9100 Fax no (033) 417-1393

*Fire Brigade* tel no (033) 417 2911  
Email: records@umvoti.gov.za

### *Municipal Management:*

Email: mmpa@umvoti.gov.za  
Tel no (033) 413-9101 Fax no (033) 417-1393

### *Fire Service:*

Tel no (033) 413 9134  
Cell no 079 491 9938

### *Disaster Management:*

Tel no (033) 413 1322 Fax no 033 413 9134

### *Communications:*

Tel no (033) 413-9161

## UMZINYATHI DISTRICT DISASTER MANAGEMENT CENTRE

### **AREAS UNDER CONTROL**

Glencoe, Dundee

### **CONTACT INFORMATION**

8 Diaz Str Dundee 3000  
Tel no (034) 212-2222 Fax no 086 521 8009  
All hours control room (034) 212-2222

### *Municipal Management:*

Tel no (034) 219 1500  
Email: mm@umzinyathi.gov.za

### *Disaster Management:*

Cell no: 082 436 8688

### **STATISTICS**

*Population:* 35 000

## UPHONGOLO LOCAL MUNICIPALITY

### **AREAS UNDER CONTROL**

Pongola

### **CONTACT INFORMATION**

61 Martin St, Pongola  
PO Box 191 Pongola 3170  
Tel no (034) 412 1223 Fax (034) 413-1706  
Email: info@uphongolo.gov.za

### *Traffic Department:*

Tel no (034) 413 2497

### *Municipal Management:*

Tel no (034) 413-1223 Fax no (034) 413-1706  
E-mail: mm@uphongolo.gov.za

### *Human Resources:*

Tel no (034) 413-1223

### *Protection Services:*

Cell no 082 832 9454

### *Traffic Services:*

Tel no (034) 4132497

### *Ambulance Service:*

10177 / (034) 413 1323

### **STATISTICS**

*Size of area:* 157 sq kms

*Population:* Trust:147000 - Sugar Mill:2000 - Farmers:2000 - Pongola Town:6800

## EPHRAIM MOGALE LOCAL MUNICIPALITY

### **AREAS UNDER CONTROL**

Marble Hall, Leeuwfontein,

### **CONTACT INFORMATION**

*Traffic / Fire / Rescue and Disaster*  
13 Ficus Str Marble Hall  
PO Box 111 Marble Hall 0450  
Website: www.ephraimmogalelm.gov.za  
Tel no (013) 261-8400 Fax no (013) 261-2985

### *Municipal Management:*

Tel no (013) 261 8401

### *Corporate Services:*

Tel no (013) 261 8404

### *Leeuwfontein Office:*

Tel no (013) 266-7025

### **STATISTICS**

*Size of area:* 80,59 sq kms

*Population:* ± 172 000

## MOGALAKWENA MUNICIPALITY FIRE DEPARTMENT

### **AREAS UNDER CONTROL**

Potgietersrus, Mokopane

### **CONTACT INFORMATION**

32 Nelson Mandela Dr Mokopane  
PO Box 34 Mokopane 0600  
Switchboard no (015) 491 9600  
Tel no (015) 491-9800 Fax no (015) 491-9755  
Cell no 082 300 1414

### *Municipal Management:*

Tel no (015) 491-9604

### *Traffic & Emergency Services:*

Tel no (015) 491 9813

### *Community Services Management:*

Tel no (015) 491 9607

### **STATISTICS**

*Size of area:* ± 30 kms radius

*Population:* ±600 000

## MOOKGOPHONG LOCAL MUNICIPALITY

### **AREAS UNDER CONTROL**

Naboomspruit, Roedtan, Modimolle

### **CONTACT INFORMATION**

Mandela Drive, Mookgophong  
Private Bag X340 Mookgophong 0560  
Tel no (014) 743-6600  
Fax no (014) 743-2434  
Email: admin@mookgophong.gov.za

### *Municipal Management:*

Tel no (014) 718 2000

### *Communications:*

Tel no (014) 743 6600

### **STATISTICS**

*Size of area:* ± 568 km radius

*Population:* 32000

## MOPANI DISTRICT MUNICIPALITY

### **AREAS UNDER CONTROL**

Giyani, Modjadjiskloof, Tzaneen, Ba-Phalaborwa, Maruleng

### **CONTACT INFORMATION**

Old Parliament Building  
Government Building, Main Road, Giyani  
Private Bag x 9687 Giyani, 0826  
Tel no (015) 306 7010 Fax no (015) 812 4301

CCC (Centralised Communication Centre for reporting of emergencies (015) 306 7000 / 307 5555 / 060 551 1911 / 060 551 1910

### **FIRE STATIONS**

*Tzaneen Fire Station*  
Tel no (015) 307 8000

### *Modjadjiskloof Fire Station:*

Tel no (015) 309 8660

### *Giyani Fire Station:*

Tel no (015) 812 5030

### *Ba-Phalabora:*

Tel no (015) 781 1333

### *Maruleng Fire Station:*

Tel no (015) 793 0728

## OBED MASHABA FIRE STATION

### **AREAS UNDER CONTROL**

Vhembe

### **CONTACT INFORMATION**

National Road Musina  
Private Bag x 611 Musina 0900  
Switchboard tel no (015) 534-7401  
Tel no (015) 534-0061  
Emergency no (015) 534-0270 / 0061  
Fax no (015) 534-3133  
Email: info@musina.gov.za

### *Fire Services:*

Tel no (015) 964 4500 / (015) 534 0270 / 3642

### *Municipal Manager:*

Tel no (015) 534-6181 Fax no (015) 534-2513

### *Communications:*

Tel no (015) 534-6132 Fax no (015) 534-2513

### **STATISTICS**

*Size of area:* ± 12 000 sq kms

*Population:* 60 000

## POLOKWANE MUNICIPALITY FIRE & EMERGENCY SERVICES

### **AREAS UNDER CONTROL**

Pietersburg, Mankweng, Seshego, Moletji, MajaChuene, Sebajeng

### **CONTACT INFORMATION**

Vermiculite Str Laboria Pietersburg  
PO Box 111 Polokwane 0700  
Tel no (015) 290-2000 Fax no (015) 290-2450  
Emergency no (015) 293-1111

### *Fire Department:*

(015) 290 2403/5

### *Municipal Management:*

Tel no (015) 290 2102

### *Disaster Management:*

Tel no (015) 290 2405

### *Environmental Health:*

Tel no (015) 290 2350

### **STATISTICS**

*Size area:* 10,000 sq kms

*Population:* ± 60 000

*Fire stations:* 2

# LIMPOPO

## BA-PHALABORWA MUNICIPALITY

### PROTECTION SERVICES FIRE & RESCUE OPERATIONS

#### Falls under Mopani District Municipality

### **AREAS UNDER CONTROL**

Phalaborwa to Strydom tunnel, Mopani, Giyane

### **CONTACT INFORMATION**

#### *Mopani District Municipality Fire & Rescue Services*

Cnr Palm and Sealene St Phalaborwa

Private Bag x 9687 Giyane 0826

Tel no (015) 781-7081/781-7008

Emergency no (015) 781-1333

Fax no (015) 781-7082 Cell no 061 887 1208

### *Municipal Management:*

Tel no (015) 811 6300

### *Fire Services:*

Tel no (015) 781-7081/781-7008

### *Station Commander Ambulances:*

Tel no (015) 769-4011

### *Disaster Manager: KJ Mphahlele*

Tel no (015) 780-6300

### *Traffic Services:*

Tel no (015) 780-6300

### **STATISTICS**

*Size area:* ± 299 975sq kms

*Population:* ± 129134

## BELA-BELA MUNICIPALITY FIRE DEPARTMENT

### **AREAS UNDER CONTROL**

Warmbaths, Waterberg

### **CONTACT INFORMATION**

59 Chris Hani Drive Warmbaths

Private Bag X1609 Bela Bela 0480

Tel no (014) 736-8000 Fax no (014) 736-3288

### *Protection and Emergency Management:*

Tel no 014 718 3300 Fax no (014) 717 2931

### **STATISTICS**

*Population:* 40 000

## ELIAS MOTSOLEDI LOCAL MUNICIPALITY FIRE DEPARTMENT

### **AREAS UNDER CONTROL**

Groblerdal

### **CONTACT INFORMATION**

2 Grobler Ave Groblersdal

PO Box 48 Groblersdal 0470

Tel no (013) 262-3056 Fax no (013) 262-4883

Emergency Tel no: 013 262 3024

### *Fire services:*

Tel no (013) 262 7300

### **STATISTICS**

*Population:* approx 320 000

## **THABAZIMBI MUNICIPALITY PROTECTION SERVICES**

### **AREAS UNDER CONTROL**

Northam, Rooiberg, Leeupoort, Dwaalboom, Thabazimbi

### **CONTACT INFORMATION**

7 Rietbok Str Thabazimbi  
Private Bag X530 Thabazimbi 0380  
Tel no (014) 777-1525 Fax no (014) 777-1531  
Email: info@thabazimbi.gov.za  
Emergency standby cell no: 083 687 1883  
Limpopo Province Emergency Medical Services: 10117  
Email: info@thabazimbi.gov.za

## **TZANEEN, GREATER MUNICIPALITY**

### **Falls under Mopani District Municipality**

### **CONTACT INFORMATION**

PO Box 24 Tzaneen 0850  
Tel no (015) 307-8000  
Fax no (015) 307-8049  
Fire Department Tel no (015) 306-7051  
EMS tel no (015) 307 7077  
Disaster no (015) 306 7010

### *Municipal Management:*

Tel no (015) 307-8246

### *Fire Services:*

Tel no (015) 306 7051

### *Mopani Sub-station*

Emergency tel no (015) 307 5555 / 6666  
Disaster Centre tel no (015) 306 7000

### **STATISTICS**

*Size of area:* 3240 sq kms  
*Population:* 484 053 000

## **VHEMBE DISTRICT MUNICIPALITY FIRE BRIGADE**

### **AREAS UNDER CONTROL**

Louis Trichardt, Mokhado, Vuwani, Obed Mashaba, Musina, Thohoyandou

### **CONTACT INFORMATION**

Private Bag X5006 Thohoyandou 0950  
Tel no (015) 961 6944 / 6913

### *Municipal Management:*

Tel no (015) 960 2009

### *Fire Services:*

Tel no (015) 964 4500

### *Training Services:*

Tel no (015) 968 6801

### **FIRE STATIONS**

*Makhado Fire Station* (Louis Trichardt)  
Tel no (015) 516 5588

### *Vuwani Fire Station*

Tel no (015) 961 6944 /6916

### *Obed Mashaba Fire Station* (Musina)

Tel no (015) 534 0270

### *Ramushwana Fire Station* (Thohoyandou)

Tel no (015) 962 4155/0972

### *Mutale Fire Station*

Tel no (015) 967 0123/0121

### *Xigalo Fire Station*

Tel no: (015) 851 6079

### **STATISTICS**

*Population:* ±532 085  
*Size of area:* 16 000 sq kms

## **WATERBERG DISTRICT MUNICIPALITY**

### **AREAS UNDER CONTROL**

Modimolle, Waterberg

### **CONTACT INFORMATION**

Harry Gwala Street, Modimolle  
Private Bag X1018 Modimolle, 0510  
Tel no (014) 718 3300  
Fax no (014) 717 2931

### *Municipal Management:*

Tel no (014) 718 3321 / 3320 Fax no (014) 717 2931

### *Communications:*

Tel no (014) 718 3324 Fax no (014) 717 3689

### *Fire Services:*

Cell no 082 664 1159  
Fax no (014) 717 2931

### **STATISTICS**

*Size of area:* 50 sq kms

*Population:* 80 737

### **FIRE STATIONS AND OFFICES**

*Volksrust Fire Station*  
C/O Laingsnek and Joubert Street Volksrust 2470

### *Perdekop Office*

Tel no (017) 785 1197

### *Wakkerstroom Office*

Tel no (017) 730 0069

### *Amersfoort Office*

Tel no (017) 753 1006

## **EMAKHAZENI MUNICIPALITY FIRE AND RESCUE SERVICES**

### **AREAS UNDER CONTROL**

Belfast, Dullstroom, Waterval-Boven, Siyathuthuka, Emthonjeni, Entokozweni

### **CONTACT INFORMATION**

25 Scheepers Str Belfast  
PO Box 17 Belfast 1100  
Tel no (013) 253-7600 Fax no (013) 253-1889  
Email: municipality@emakhazenilm.gov.za

### *Fire Services:*

Tel no (013) 253 7643

### *Planning Infrastructure & Social Development:*

Tel no (013) 253 7648

### **STATISTICS**

*Size area:* 100 km radius  
*Population:* approx 47 000  
*Fire stations:* 2 firehouses

### **FIRE STATIONS / OFFICES**

#### *Siyathuthuka Office:*

Tel no (013) 253 7668

#### *Waterval Boven Office:*

Tel no (013) 253 7680

#### *Dullstroom Office:*

Tel no (013) 253 7687

#### *Emthonjeni Office:*

Tel no (013) 253 7694

#### *Entokozweni Office:*

Tel no (013) 253 7686

## **EMALAHLENI LOCAL MUNICIPAL COUNCIL FIRE DEPARTMENT**

### **AREAS UNDER CONTROL**

Witbank, Kriel, Ogies

### **CONTACT INFORMATION**

*Witbank Emergency Services*  
Cnr Beaty and OR Tambo Streets, Emalahleni  
PO Box 3 Emalahleni 1035  
Switchboard: Tel no (013) 690-6911 Fax no (013) 690-6380  
Emergency no (013) 690-6222/6333/6444  
Email: admin@emalahleni.gov.za

### *Municipal Management:*

Tel no (013) 690-6911 Fax no (013) 690-6207

### *Fire Services:*

Tel no (013) 653 5751 / 5754

### *Disaster Management:*

Tel no (013) 653 5758 / 653 5753

### **FIRE STATIONS:**

#### *Witbank*

Tel no (013) 653-5756

### *eMalahleni*

Tel no (013) 653 5753

### **STATISTICS**

*Size of area:* 2 800 sq kms  
*Population:* ± 508 153

## **GOVAN MBEKI MUNICIPALITY**

### **AREAS UNDER CONTROL**

Secunda, Bethal, Emzimoni, Trichardt, Embalenhle, Evander, Kinross, Thistle Grove, Lebohang, Leandra, Charl Celliers

### **CONTACT INFORMATION**

Central business Area Horwood St, Secunda  
Private Bag X1017 Secunda 2302  
Tel no (017) 620-6000 Fax no (017) 634 8019  
Email: callcentre@govanmbeki.gov.za

### *Municipal Management*

Tel no (017) 620-6279 Fax no (017) 634-8818

### *Communications:*

Tel no (017) 620-6254 Fax no (017) 634-8818

### *Fire Services:*

Tel no: (017) 620 6306

### **FIRE STATIONS**

#### *Bethal & Emzimoni Fire Stations*

Cell no 082 704 6660

#### *Secunda Fire Station*

Cell no 076 706 9044

#### *Embalenhle Fire Station*

Cell no 082 682 5917

#### *Evander Fire Station*

Cell no 082 745 5428

#### *Leandra Fire Station*

Cell no 073 475 4040

### **STATISTICS**

*Size of area:* 2958 sq kms  
*Population:* 494 538  
*Fire stations:* 6

## **LEKWA MUNICIPALITY FIRE & RESCUE SERVICE**

### **AREAS UNDER CONTROL**

Standerton, Morgenson

### **CONTACT INFORMATION**

Cnr Dr Beyers Naude & Mbonani Mayisela Streets, Standerton  
PO Box 66 Standerton 2430  
Switchboard tel no: (017) 714 6102  
Fax no (017) 712 6808

### *Municipal Management:*

Tel no (017) 712 9628

### *Communications:*

Tel no (017) 712-9614 Fax no (017) 712-6808

### *Disaster Management:*

Tel no (017) 712-1065 ext 104

### *Community Services and Safety:*

Tel no (017) 712 1184 / 86 Fax no (017) 712 6808

### **STATISTICS**

*Size of area:* 11 640 sq kms  
*Population:* 280 000

### **FIRE STATIONS**

#### *Standerton Station*

Tel no (017) 712-5458

Emergency (017) 712-5551 / (017) 7125458

# MPUMALANGA

## **CHIEF ALBERT LUTHULI MUNICIPALITY FIRE, RESCUE AND DISASTER MANAGEMENT**

### **AREAS UNDER CONTROL**

Carolina, Emanzana, Empuluzi, Elukwatini, Ekulindeni

### **CONTACT INFORMATION**

28 Kerk Str Carolina  
PO Box 24 Carolina 1185  
Head Office Tel no (017) 843-4000 ext 236  
Fax no 086 639 4001  
Emergency no (017) 843 4011 Stand by no 082 439 2785

### *Municipal Management:*

Tel no (017) 843-4000

### *Communications:*

Tel no (017) 843 4000

### *Community and Public Safety Directorate:*

Tel no (017) 843 4000

### *Fire, Rescue & Disaster Management*

Tel no (017) 843 4000 Fax no 086 6178 817

### *Fire Station*

1016 Pearce Street

### **STATISTICS**

*Population:* ± 208812

## **DR PIXLEY KA ISAKA SEME LOCAL MUNICIPALITY FIRE BRIGADE SERVICES**

### **AREAS UNDER CONTROL**

Volksrust, Amersfoort, Wakkerstroom, Perdekop, Daggakraal

### **CONTACT INFORMATION**

Cnr Adelaide Tambo & Dr Nelson Mandela Drive Volksrust  
Private Bag X9011 Volksrust 2470  
Tel no (017) 734-6100/6101 Fax no (086-630-2209)  
Email: records@pixleykaseme.gov.za

### *Municipal Management:*

Tel no (017) 734 6101

Email: mm@pixleykaseme.gov.za

### *Communications:*

Tel no (017) 734-6159

Cell: 072-186-2483

### *Public Safety:*

Tel no (017) 734 6334 Fax no 086 630 2209

Morgenon Sub-Station  
Tel/Fax no (017) 793-3520  
Tel no 24 hours (017) 712-5551 / (017) 793 3496  
Fax no (017) 712-6808

**MBOMBELA MUNICIPALITY FIRE & RESCUE SERVICES & EMERGENCY SERVICES**

**AREAS UNDER CONTROL**

Barberton, Nelspruit, White River, Hazeyview, Nsikazi

**CONTACT INFORMATION**

150 Henshall Str Nelspruit  
PO Box 45 Nelspruit 1200  
Switch Board Tel no (013) 759-9111  
Tel no (013) 759 2129 / 31 Fax no (013) 753-3018/9  
Emergency No (013) 753 3331

**Municipal Management:**

Email: mm@mbombela.gov.za  
Tel no (013) 759-2231 Fax no (013) 759-2274

**Communications:**

Tel no (013) 759-2268 Fax no (013) 759-2331

**STATISTICS**

Size area: ± 70 000 sq kms

Population: ± 600 000

Emergency calls:- Rescues: 298 - Grass/veld fires:266 - Building fires:181 - Dwelling fires:75 - Vehicle Accidents:431

Fire stations: 3

Personnel:- Officers:7 - Full-time fire fighters:52 - Volunteer fire fighters:20 - Dispatchers:10

**MKHONDO MUNICIPALITY FIRE DEPARTMENT**

**AREAS UNDER CONTROL**

Piet Retief, Amsterdam, Dirkiesdorp)

**CONTACT INFORMATION**

Municipality: 33 Mark Street Piet Retief  
PO Box 23 Piet Retief 2380

Fire Station: Cnr Market & De Wet St, Piet Retief 2380

Cell no 079 872 8989 / 083 494 7540

Fax no 086 242 2148

Email: info@mkhondo.gov.za

**Municipal Management**

Tel no (017) 826-8101

**STATISTICS**

Population: 160 000

Size of area: 4868,153 sq kms

**MSUKALIGWA LOCAL COUNCIL**

**DEPARTMENT OF COMMUNITY AND SOCIAL SERVICES**

**AREAS UNDER CONTROL**

Breyten, Ermelo, Davel, Lothiar, Chrissiesmeer, Sheepmoor, Warburton, New Scotland

**CONTACT INFORMATION**

Church Str, Ermelo 2350  
PO Box 48 Ermelo 2350  
Tel no (017) 801-3400 Fax no (017) 801-3851  
Switchboard: (017) 801 3500

**Municipal Management:**

Tel no (017) 801-3504 Fax no (017) 801-3661

**Community and Health Services:**

Tel no (017) 801-3503 Fax no (017) 801-3660

**Director Public Safety:**

Tel no (017) 801 3402/5 Fax no (017) 801 3424

**Fire Services:**

Tel no (017) 801 3402 / 3409 Fax no (017) 801 3424/3417

**Disaster/Security:**  
Tel no (017) 801 3412

**Traffic:**

Tel no (017) 801 3409 Cell no 072 311 9833

**Licensing:**

Tel no (017) 801 3430 Cell no 083 760 6718

**FIRE STATIONS**

Fire stations:2 - Substations:2

**Breyten Sub-Station Section**

Breytenbach Str Breyten

PO Box 48 Ermelo 2350

Tel no (017) 819-2472 Fax no (017) 819-2472

**STATISTICS**

Size of area: 8,0 sq kms

Population: 23 000

**Ermelo Fire Section**

Cnr Border & Wedgewood Strs 2350

PO Box 48 Ermelo 2350

Tel no (017) 819 2472 Fax no (017) 819-2472

**STATISTICS**

Size of area: 51 sq kms

Population: 96219

**STEVE TSHWETE LOCAL MUNICIPALITY FIRE & RESCUE SERVICES**

**AREAS UNDER CONTROL**

Hendrina

**CONTACT INFORMATION**

Lilian Ngoyi Street

PO Box 14 Middelburg 1050

Switchboard: Tel no (013) 249-7000

Fire Dept: Tel no (013) 243-2222 / (013) 249-7222

Fax no 086 204 2123

**Municipal Management:**

Tel no (013) 249-7263 Fax no (013) 243-2550

**Communications:**

Tel no (013) 249-7053 Fax no (013) 243-2550

Cell no 082 338 3821

**Fire Services:**

Tel no (013) 249-7322

**Community Services:**

Tel no (013) 249-7306

**Disaster Management:**

Tel no (013) 249-7270

**Traffic & Security Services:**

Tel no (013) 249 7030

**STATISTICS**

Size of area: 3 997 sq kms

Population: 230 000

**FIRE STATIONS**

Hendrina Fire Station

Arnot Road Hendrina

Tel no (013) 293-0011

**THABA CHWEU MUNICIPALITY FIRE DEPARTMENT**

**AREAS UNDER CONTROL**

Lydenburg, Sabie, Graskop, Pilgrims Rest, Moremela, Leroro, Matibidi

**CONTACT INFORMATION**

Cnr Viljoen & Central Str Lydenburg

PO Box 61 Lydenburg 1120

Tel no (013) 235-7300 Fax no (013) 235 1108

**Municipal Management:**

Email: mm@thabachweumun.gov.za

**Community and Social Services:**

Tel no (013) 235 7300

**Fire & Emergency Services:**

Tel no (013) 235 7570

**Disaster Management:**

Cell no 082 493 7103

**STATISTICS**

Population: 160 000

Size of area: 5500sq kms

# NORTHERN CAPE

**DAWID KRUIPER MUNICIPALITY FIRE & RESCUE**

**AREAS UNDER CONTROL**

Upington, Mier

**CONTACT INFORMATION**

Cnr Anton Lubowski & Dakota Rd Upington

Private Bag X6003 Upington 8800

Tel no (054) 338 7405 Fax no (054) 332-4524

**Municipal Management:**

Tel no (054) 338 7001 Fax no (054) 332 4526

**Communications:**

Tel no (054) 338-7008 Fax no (054) 338-7350

Email: communications@dkm.gov.za

**Community Services:**

Tel no (054) 338 7047 Fax no (054) 331 1857

**Fire & Disaster Management:**

Tel no (054) 338 7186 / (054) 332 4526

Email: fire@dkm.gov.za

**Traffic:**

Tel no (054) 338 7421 Fax no (054) 332 1563

Email: trafficadmin@dkm.gov.za

**Security Services:**

Tel no (054) 338 7174 Fax no (054) 332 1870

**STATISTICS**

Size of area: 471 769 sq kms

Population: 100 000

**EMTHANJENI MUNICIPALITY**

**AREAS UNDER CONTROL**

De Aar, Hanover, Britstown

**CONTACT INFORMATION**

45 Voortrekker St, De Aar

PO Box 42 De Aar 7000

Tel no (053) 632-9100 Fax no (053) 631-0105

Emergency / After hours tel no: 082 887 4024

**Municipal Management:**

Cell no 082 802 2319

**Fire Brigade:**

Tel no: (053) 631 0860

**Traffic:**

Tel no (053) 632-9100

**STATISTICS**

Size of area: 13 000 sq kms

Emergency calls:26

Fire stations: 2

**FIRE STATIONS**

Graskop Fire Station

Main Street Graskop PO Box 18 Graskop, 1270

Lydenburg Fire Station

Tel no (013) 235 1788 Fax no (013) 235 2227

Thaba Chweu - Lydenburg

Tel no (013) 235 1788 / 7370

Sabie Fire Station

6th Avenue, Sabie PO Box 61 Lydenburg 1120

Tel/Fax no (013) 764 2249

Thaba Chweu Fire Station

Tel no (013) 235 1788

**FIRE STATIONS**

Hanover Fire Station:

Tel no (053) 643-0026

Britstown Fire Station:

Tel no (053) 672-0202

Personnel:- Volunteer Fire fighters:11

**GAMAGARA MUNICIPALITY**

**AREAS UNDER CONTROL**

Kathu

**CONTACT INFORMATION**

Cnr Hendrik Van Eck & Frikkie Meyer Road, Kathu, 8446

PO Box 1001 Kathu 8446

Tel no (053) 723-6000 Fax no (053) 723-2021

Email: info@gamagara.gov.za

**GA-SEGONYANA MUNICIPALITY FIRE DEPARTMENT**

**AREAS UNDER CONTROL**

Batlharo Ba Ga Motlhwane, Ga Mohana, Gathlose, Kudumane,

Kuruman Part 1, Kuruman Part 2, Mothibistad

**CONTACT INFORMATION**

Cnr Voortrekker & School Str Kuruman

Private Bag X1522 Kuruman 8460

Tel no (053) 712-9300 Fax no (053) 712-3581

Fire Emergency tel no 083 448 9223

**Municipal Management:**

Tel (053) 712-9301

**Corporate Services:**

Tel no (053) 712-9302

**STATISTICS**

Size of area: 91 4 sq kms

Emergency calls: 8

**KAI! GARIB MUNICIPALITY FIRE DEPARTMENT**

**AREAS UNDER CONTROL**

Kakamas, Keimoes, Kenhardt

**CONTACT INFORMATION**

9 11th Ave Kakamas

Private Bag X6 Kakamas 8870

Tel no (054) 461 6700 Fax no (054) 431 6338

**Municipal Management:**

Tel no (054) 431 6328

Email: mm@kaigarib.gov.za

**Communications:**

Tel: 054 431 6332

Planning and Development:  
Tel no (054) 461 6406

Technical Services:  
Tel no (054) 461 6309

#### STATISTICS

Personnel:- Fire fighters:1

#### SUBSTATIONS

Keimoes Substation  
Hoos St Keimoes  
PO Box 8 Keimoes 8860  
Tel no (054) 461 6700

Kenhardt Office  
Tel no (054) 651 6500

#### NAMAKWA DISTRICT MUNICIPALITY FIRE DEPARTMENT

##### AREAS UNDER CONTROL

Springbok, Nama Khoi

##### CONTACT INFORMATION

###### Springbok Fire Department

Van Riebeeck Str Springbok  
Private Bag X 20 Springbok 8240  
Tel no (027) 712-8000  
Fax (027) 712-8040

Email: info@namakwa-dm.gov.za

##### Municipal Management:

Tel no (027) 712 8000  
Fax no (027) 712 8040

##### Disaster, Fire and Incident Services:

Tel no (027) 712 8000  
Cell no 084 511 7481  
Fax no (027) 712 8040 / 086 484 9772

##### Nama Khoi Municipality Fire Department

4 Namakwa Str Springbok  
PO Box 17 Springbok 8240  
Tel no (027) 718 8100  
Fax no (027) 712 1635  
After hours emergency Cell: 079 924 3092

##### Municipal Management:

Tel no (027) 718 8100  
Fax no (027) 712 1635

Email: municipal.manager@namakhoi.gov.za

##### Fire and Disaster Management :

Tel no (027) 718 8106  
Fax no 086 486 0246

#### SIYATHEMBA MUNICIPALITY FIRE DEPARTMENT

##### AREAS UNDER CONTROL

Prieska, Marydale, Niekershoop

##### CONTACT INFORMATION

Victoria Str Prieska  
PO Box 16 Prieska 8940  
Tel no (053) 353-5300  
Fax no (053) 353-1386 / 086 606 2716

##### Fire / Technical Services:

Tel no (053) 353-5312  
Fax no (053) 353 1386

##### Traffic:

Tel no (053) 353 5327

##### STATISTICS

Size of area: 175 sq kms  
Population: ± 17517

#### FIRE STATIONS

Marydale Fire Station  
Van Wyk Str Marydale  
PO Box 33 Marydale 8910  
Tel no (054) 871-0007  
Fax no (054) 871-0035

#### SOL PLAATJIE MUNICIPALITY EMERGENCY SERVICES

##### AREAS UNDER CONTROL

Kimberley

##### CONTACT INFORMATION

21 Lyndhurst Rd Kimberley  
Private Bag X5030 Kimberley 8300  
Emergency Tel no (053) 832-4211/2/3/4/5 / 2222  
Tel no (053) 832 4214/5 Fax no 086 536 4721

##### City Management:

Tel no (053) 830-6100

##### Emergency Services & Disaster Management:

Tel no (053) 832-4233 Fax no 086 536 4721

##### Traffic Services:

Tel no (053) 831-4348

##### STATISTICS

Size area: ± 1876.92 sq kms

Population: ± 350 000

Value of area: ± R2 billion

#### THEMBELIHLE MUNICIPALITY FIRE DEPARTMENT

##### AREAS UNDER CONTROL

Hopetown, Strydenburg

##### CONTACT INFORMATION

Church Str Hopetown  
Private Bag X3 Hopetown 8750  
Tel no (053) 203-0008/5  
Fax no (053) 203-0490  
Fire Brigade Tel no (053) 203 0951

##### STATISTICS

Size of area: 60 sq kms

Population: 15 000

#### TSANTSABANE MUNICIPALITY

##### AREAS UNDER CONTROL

Postmasburg

##### CONTACT INFORMATION

13 Springbok Str Postmasburg  
P O Box 5 Postmasburg 8420  
Tel no (053) 313-7300  
Fax no (053) 313-1602  
Traffic / Fire Services:  
Tel no (053) 313-7300  
Fax no (053) 313-0353

#### UMSOBOMVU MUNICIPALITY FIRE DEPARTMENT

##### AREAS UNDER CONTROL

Colesberg, Noupoot, Norvalspont

##### CONTACT INFORMATION

21A Church St Colesberg  
Private Bag X6 Colesberg 9795  
Tel no (051) 753-0777  
Fax no (051) 753-0574

# NORTH WEST

#### BOJANALA PLATINUM DISTRICT MUNICIPALITY

##### AREAS UNDER CONTROL

Rustenburg, Koster, Mogwase. Moretele

##### CONTACT INFORMATION

Cnr Fatima Bhayat & Beyers Naude Rustenburg  
PO Box 1993 Rustenburg 0300  
Tel no (014) 590-4500  
Email: info@bojanala.gov.za

##### Municipal Management:

Tel no (014) 590-4502 Fax no (014) 597 0306

##### Communications:

Tel no (014) 590-4531  
Fax no (014) 592-6085

##### Community Development Services:

Tel no (014) 592 4303

##### District Disaster Management:

Tel no (014) 592 6321 / 4495 Fax no (014) 592 4393

##### Fire & Rescue Services:

Tel/fax no (014) 543 4537

##### SUBSTATIONS

###### Koster sub-station

4 Patent Street, c/o Patent & Robinson, Koster  
Telefax no (014) 543 4537

###### Mogwase sub-station

No 2 Second Street, Bodirelo Industrial Township  
Telefax no (014) 558 2779

###### Moretele Fire Station

Moretele office Park, Makapanstad  
Tel no 083 258 6342

#### DITSOBOTLA LOCAL MUNICIPALITY FIRE DEPARTMENT

##### AREAS UNDER CONTROL

Lichtenburg, Coligny, Itsooseng

##### CONTACT INFORMATION

Cnr Nelson Mandela Dr & Transvaal St Lichtenberg  
PO Box 7 Lichtenburg 2740  
Tel no (018) 632 1474 / 1647  
Regional control centre no (018) 632-1474

##### Municipal Management:

Tel no (018) 632-3800  
Email: info@ditsobotla.gov.za

##### Fire Service:

Tel: (018) 632-1474

##### STATISTICS

Population: ± 200 000

##### SUB-STATIONS

###### Coligny substation

Tel no (018) 632 1474

###### Itsooseng substation

Tel no (018) 338 1007

#### DR RUTH S MOMPATI DISTRICT MUNICIPALITY

##### AREAS UNDER CONTROL

Lekwa-Teemane, Greater Taung, Kagisano/Molopo, Mamusa

##### CONTACT INFORMATION

50 Market Str Vryburg  
PO Box 21 Vryburg 8600  
Tel no (053) 928 4700 Fax no (053) 927-2401

##### Fire & Disaster Management:

Tel no (053) 927-3235 Fax no (053) 927-3256

##### Ambulance Service:

Tel no (053) 927 0456

##### Disaster Management:

Cell no 072 828 9210

#### KGETLENG RIVIER MUNICIPALITY

##### AREAS UNDER CONTROL

Koster, Derby, Swartruggens

##### CONTACT INFORMATION

Cnr De Wet & Smuts Strs Koster  
PO Box 66 Koster 0348  
Fire Department (Bojanala) tel no (014) 543 4537 / 2004  
083 678 6839 / 083 258 6244  
Fax no (014) 543 4086 /2480

#### JB MARKS LOCAL MUNICIPALITY

##### AREAS UNDER CONTROL

Potchefstroom, Ventersdorp,

##### CONTACT INFORMATION

###### Head Office - Potchefstroom

Cnr Wolmaranstad and Sol Plaatjie Street  
PO Box 113 Potchefstroom 2520  
Tel no (018) 299 5003

##### Department of Community Safety:

Cnr Nelson Mandela and Poortman Streets, Potchindustria  
Potchefstroom  
PO Box 113 Potchefstroom 2520  
Emergency no (018) 293-1111/2/22

##### Community Safety:

Tel no (018) 299-5341/ 5533

##### Division: Fire Brigade Services:

Potchefstroom Fire Station  
Cnr Luiting and Poortman Streets, Potchindustria, Potchefstroom  
Tel no (018) 299 5343 /49 Fax no 086 212 9375

##### Ventersdorp Fire Station

11 Van Tonder Street Ventersdorp  
Tel no (018) 264 8538

##### Fire Brigade Services Training Centre:

Tel no (018) 299 5343

##### Fire Safety and Prevention Services:

Tel no (018) 299 5343 / 5811 / 5370

##### Rescue Services

Tel no (018) 299 5343 / 8538

##### Operations:

Tel no (018) 299 5343 / 44

##### Training:

Tel no (018) 299 5374 / 5343

##### Disaster Management Centre / Public Awareness:

Cnr Nelson Madela Drive and Walter Sesulu Street Potchefstroom  
Tel no (018) 299 5820 / 5540 / 5347  
After hours (071) 860 7619

##### Crisis Control:

Tel no (018) 299 5826 /5347

##### Dispatch Centre:

Tel no (018) 299-5347

##### STATISTICS

Size of area: 6 434.66 sq kms

Population: 318 184

**LEKWA-TEEMANE LOCAL MUNICIPALITY**

**AREAS UNDER CONTROL**

Bloemhof, Christiana

**CONTACT INFORMATION**

Cnr Dirkie Uys & Robyn St Christiana  
PO Box 13 Christiana 2680  
Tel no (053) 441-2206 / 7 / 8 / (053) 441-3952 / 56  
Fax no (053) 441-3735  
Email: registry@lekwa-teemane.co.za

**Municipal Management:**

Tel no (053) 441 2206/7/8

**Corporate Services:**

Tel no (053) 433 1018

**Community Services:**

Tel no (053) 443 1018

**Bloemhof Sub-Office**

Tullekin Street, Bloemhof P O Box 116, Bloemhof, 2660  
Tel no (053) 433 1017/8 / (053) 433 1202/2119

**Boitumelong Sub Office**

Tel no (053) 432 0111

**Utlwanang Sub Office**

Tel no(053) 442 8011

**MADIBENG LOCAL MUNICIPALITY FIRE DEPARTMENT**

**AREAS UNDER CONTROL**

Brits

**CONTACT INFORMATION**

Cnr Hendrik Verwoerd and Crocodile Str, Brits  
PO Box 106 Brits 0250  
Tel no (012) 250 2222 Fax no (012) 250 1221  
Emergency no - 24 hours (012) 250-2222 / 250-2127

**Municipal Management:**

Email: munman@madibeng.gov.za  
Tel no (012) 318 9212 / (012) 328 9100

**Public Safety and Social Services:**

Tel no (012) 318 9410

**Traffic:**

Tel no (012) 250 2222

**STATISTICS**

Size of area: 3832 sq kms

Population: 342799

Satellite Station: Lethlabile

**MAMUSA LOCAL MUNICIPALITY FIRE DEPARTMENT**

**AREAS UNDER CONTROL**

Schweizer-Reneke

**CONTACT INFORMATION**

28 Schweizer Str Schweizer-Reneke  
PO Box 5 Schweizer-Reneke 2780  
Tel no (053) 963-1331 Fax no (053) 963-2474

**Technical Services:**

Tel no (053) 963 1332

**STATISTICS**

Size of area: ±100 sq kms

Population: ± 70 000

**Fire stations/store:**

Corner Swart and Buiten Street, Schweizer-Reneke

**MAQUASSI HILLS LOCAL MUNICIPALITY/**

**PUBLIC SAFETY DIVISION**

**AREAS UNDER CONTROL**

Wolmaransstad, Leeudoringstad, Makwassie, Witpoort

**CONTACT INFORMATION**

19 Kruger Street Wolmaransstad  
Private Bag X3 Wolmaransstad 2630  
Tel no (018) 065 0010  
Email: admin@maquassihills.org

**Fire Department :**

Tel no (018) 596 2546 / 9455

**Disaster Management:**

Tel no (018) 406 7000

**Public Safety, Traffic Community Services:**

Tel no (018) 596 1064

**STATISTICS**

Size of area: 4644 sq kms

Population: 108 000

Fire stations: 2

**FIRE STATIONS**

**Leeudoringstad sub-station**

51 Paul Kruger Str Leeudoringstad  
Private Bag X3 Wolmaransstad  
Tel no (018) 596 1064 Fax no (018) 596 1555

**MATLOSANA, CITY OF FIRE DEPARTMENT**

**AREAS UNDER CONTROL**

Klerksdorp, Orkney, Hartebeesfontein, Stilfontein)

**CONTACT INFORMATION**

Klerksdorp Fire Department  
Cnr Viljoen & Voortrekker Strs Klerksdorp  
PO Box 99 Klerksdorp 2570  
Tel no (018) 464-8027 / 8060 / 8029 Fax no (018) 462-9648  
Emergency numbers: (018) 462 2222 / (018) 464 8020 / 60

**Municipal Management:**

Tel no (018) 487-8009 Fax no (018) 462 1652

**Communications:**

Tel no (018) 487-8567 Fax no (018) 464-1780

**Public Safety**

Tel no (018) 487 8101

**Fire Services:**

Tel no (018) 464 8046 / 8050 Fax no (018) 462 9648

**Control room:**

Tel no (018) 464 8020 Cell no 076 868 5712

**Disaster Management:**

Tel no (018) 464 8052 Fax no (018) 462 9648

**Station Officer Operations:**

Tel no (018) 464 8046 Fax no (018) 462 9648

**Station Officer: Fire Safety:**

Tel no (018) 464-8050

**Platoon Commander Fire Safety:**

Tel no (018) 464-8076 / 8025

**STATISTICS**

Size of area: 3652 sq kms

Population: 518 000

Fire stations: 3

**FIRE STATIONS**

**Klerksdorp Main Fire Station**

32 Voortrekker Street Klerksdorp  
Tel: (018) 464 8020 / 462 2222

**Orkney Sub-station**

Kingsley Ave, Orkney  
Tel no (018) 464 8020 / 462 2222

**Hartebeesfontein Sub-Station**

Voortrekker Street Hartebeesfontein  
Tel no (018) 464 8020 / 462 2222

**NGAKA MODIRI MOLEMA DISTRICT MUNICIPALITY**

**Fire & Rescue Services Unit**

**AREAS UNDER CONTROL**

Mafikeng

**CONTACT INFORMATION**

Modiri Molema Rd, Mafikeng  
Private Bag X2167 Mafikeng 2745  
Switchboard: 018 381 9400 Fax no (018) 381 4300  
Cell no 083 468 5884  
**Municipal Management:**  
Tel no (018) 381-9405 Fax no (018) 381-4300  
Email: municipalmanager@nmmmdm.gov.za

**Communications:**

Tel no (018) 381-9424

**Fire Services:**

Tel no (018) 381 9455 / 8069 Fax no 086 613 9485

**Rescue Services:**

Tel no (018) 381 9400/55

**RAMOTSHERE MOILWA LOCAL MUNICIPALITY**

**AREAS UNDER CONTROL**

Zeerust, Ikagelent, Henryville, Olienhout Park, Shalimar Park, Welbedacht, Groot Marico

**CONTACT INFORMATION**

Lehurutshe Fire Station Mangope Highway  
Private Bag X 2015 Lerato, 2880  
Email: info@ramotshere.gov.za  
Fire Dept Tel no (018) 363 3978  
Emergency no (018) 363 3977 / 8  
Switchboard no (018) 642 1081 Fax no (018) 363-3172

**Fire Services:**

Tel no (018) 363 3977

**STATISTICS**

Size area: ± 16 720 sq kms

Population: ± 160 000

**RUSTENBURG LOCAL MUNICIPALITY FIRE**

**DEPARTMENT**

**AREAS UNDER CONTROL**

Rustenburg, Marikana

**CONTACT INFORMATION**

Cnr Nelson Mandela & Bethlehem Drive, Rustenburg  
PO Box 16 Rustenburg 0300  
Municipality: Tel no (014) 590-3111  
Tel no (014) 590-3232 / 3333 / 3444 Fax no (014) 597-3924  
Emergency tel no: (014) 590-3232/3444/3853

**Fire Services:**

Tel no (014) 590/3232/3444

Email: fire@rustenburg.gov.za

**Emergency & Disaster Management:**

Cell no 064 753 5208

**Law Enforcement:**

Tel no (014) 590 3304

**Traffic:**

Tel no (014) 590-3221

**STATISTICS**

Size of area: 3416 sq kms

Population: 626 522

**TSWAING LOCAL MUNICIPALITY**

**AREAS UNDER CONTROL**

Delareyville, Sannieshof, Ottosdal, Atamelang

**CONTACT INFORMATION**

PO Box 24 Delareyville 2770  
Tel no (053) 948-9400 / 0900 Fax no (053) 948-1500

**Fire Safety:**

Tel no (053) 948 1667/1666

**STATISTICS**

Size of area: ± 450 sq kms

Population: 300 000

**FIRE STATIONS**

**Sannieshof Fire Station**

Generaal De La Rey Str, Sannieshof  
PO Box 19 Sannieshof 2760  
Tel no (018) 683-0019 Fax no (018) 683-0642

**Ottosdal sub-station**

Voortrekker Str Ottosdal  
PO Box 57 Ottosdal 2610  
Tel no (018) 871-0002 Fax no (018) 571-0448

**Atamelang Sub-Office**

Tel no (018) 334 2664  
Email: info@tswaing.gov.za

**WESTERN CAPE**

**BEAUFORT WEST LOCAL MUNICIPALITY FIRE DEPARTMENT**

**CONTACT INFORMATION**

01 Loch Street Beaufort West  
Private Bag X582  
Beaufort West 6970  
Switchboard: Tel no (023) 414-8100 /8176/4464  
Emergency no 10177  
Fax no (023) 415 1373  
Email: admin@beaufortwestmun.co.za

**Fire Services:**

Tel no (023) 414 8176 / 073 099 0508

**BERGRIVIER LOCAL MUNICIPALITY FIRE DEPARTMENT**

**AREAS UNDER CONTROL**

Piketberg, Porterville, Velddrif, Aurora, Redelinghuys, Eendekuil)

**CONTACT INFORMATION**

Church Str Piketberg  
PO Box 60 Piketberg 7320  
Tel no (022) 913-6000 / (022) 433 8700 Fax no (022) 913-1406  
**Municipal Management:**  
Email: mm@bergmun.org.za/ bergmun@telkomsa.net

**Disaster Management & Fire Service:**

Tel no (022) 913 2372

**FIRE STATIONS**

**Velddrif**

Tel no (022) 783-1112 Fax no (022) 783-1422



Porterville  
Tel no (022) 931-2100 Fax no (022) 931-3047

Aurora  
Tel no (022) 952-1720 Fax no (022) 952-1720

Eendekuil  
Tel no (022) 942-1780 Fax no (022) 942-1687

Redelinghuys  
Tel no (022) 962-1605 Fax no (022) 962-1605

#### STATISTICS

Size of area: 4400 sq kms,

#### BITOU LOCAL MUNICIPALITY PUBLIC SAFETY

##### AREAS UNDER CONTROL

Plettenberg Bay

##### CONTACT INFORMATION

##### Fire & Emergency Services / Disaster Management

Cnr Marine Way & Flying Cloud Ave

Private Bag X 1002 Plettenberg Bay 6600

Tel no (044) 501 3230/1/2/3 Fax no (044) 533-3443

Emergency tel no (044) 533 5000

##### Public Safety:

Tell no (044) 501-3240

#### STATISTICS

Size of area: 1 200 sq kms

Population: 60 000 + triple during seasonal periods

#### FIRE STATIONS

Main Fire Station (Plettenberg Bay)

Kurland Fire Station (Plettenberg East)

#### BREEDE VALLEY MUNICIPALITY FIRE AND RESCUE SERVICE

##### AREAS UNDER CONTROL

Worcester, Touwsriver, De Doorns, Rawsonville

##### CONTACT INFORMATION

Fire Brigade Headquarters: 1 Mercer Street, Worcester 6850

Private Bag X3046 Worcester 6849

24 Hours Emergency: (023) 342 2430

Free from landline: 107 Free from cellphone: 112

Website: www.bvm.gov.za

Twitter: @bvfdloc

Facebook: Breede Valley Fire Department

SARL Call Sign: ZS1 BVF

##### Senior Management:

Tel no (023) 348 9062/4

##### Municipal Management:

Tel no (023) 348 2602 Fax no (023) 348 2667

##### Fire Services:

Tel no (023) 348 9062 Fax no (023) 347 1653

Duty Officer: 24 Hours (023) 348 9074

Email: fireofficer@bvm.gov.za

##### Operations Division:

Tel no (023) 348 9064 Fax no (023) 347 1653

##### Fire Safety & Risk Management:

Tel no (023) 348 9060 / 9069 / 9065

##### Training Section:

Tel no (023) 348 9078

##### Support Services Section:

Tel no (023) 348 9067

##### Disaster Risk Management Section:

Tel no (023) 348 9065

##### Emergency Communication Section:

Tel no (023) 348 9060 /1

#### STATISTICS

Population: ±150 000

#### CAPE WINELANDS DISTRICT MUNICIPALITY

##### AREAS UNDER CONTROL

Stellenbosch, Drakenstein, Witzenberg, Breede Valley and Langeberg Local Municipalities within its area of jurisdiction

##### CONTACT INFORMATION

C/o Langenhoven and Bird Street, Stellenbosch, 7600

PO Box 100 Stellenbosch 7600

Tel (021) 888-5100

Fax (021) 886-6206

##### Municipal Management:

Email mm@capewinelands.gov.za

##### Fire Services:

Tel no (021) 888 5822

Fax no (021) 886 6206

#### STATISTICS

Size of area protecting: 22 309 sq kms

Population: 685 786

#### CAPE TOWN, CITY OF FIRE & RESCUE SERVICE

##### AREAS UNDER CONTROL

*District West:* Roeland Street, Sea Point, Salt River, Wynberg,

Constantia, Hout Bay, Epping, Brooklyn

*District North:* Goodwood, Bellville, Kraaifontein, Milnerton,

Melkbos, Atlantis, Brackenfell

*District East:* Belhar, Mfuleni, Strand, Somerset West, Khayelitsha,

Kuilsriver

*District South:* Lakeside, Fish Hoek, Simonstown, Ottery, Mitchells

Plain, Gugulethu, Lansdown

##### CONTACT INFORMATION

All emergencies from a landline: 107

Emergencies form a cellphone: (021) 480 7700

Fire & Rescue Service Command & Control Centre:

Tel no (021) 590 1900 Fax no (021) 590 4115

*Head quarters: Goodwood*

Goodwood Fire Station

Hugo Street Goodwood 7460

Private Bag X4 Parow 7499

Tel no (021) 590 1722 Fax no (021) 590 1749 / 0733

##### Fire Services:

Tel no (021) 590-1738 /1714 Fax no 086-201-2152

##### Fire & Life Safety:

Tel no (021) 590-1975 /1971

##### Training:

Tel no (021) 534-7608 Cell 071 687 8721

##### Head Command and Control:

Tel no (021) 590 1786

#### DISTRICTS

##### District West

Tel no (021) 444 8838 / 40

##### Fire Stations (Enquiries):

Roeland Street Tel no (021) 444 8963

Sea Point Tel no (021) 434 0030

Salt River Tel no (021) 444 0830

Wynberg Tel no (021) 444 9621

Constantia Tel no (021) 400 5514

Hout Bay Tel no (021) 400 7960

Epping Tel no (021) 534 1387

Brooklyn Tel no (021) 510 5180

##### District North

Tel (021) 444 8270 / 8283 Fax no (021) 918 2067

##### Fire Stations (Enquiries)

Goodwood Tel no (021) 590 1722

Durbanville Tel no (021) 444 7290

Bellville Tel no (021) 444 8279

Kraaifontein Tel no (021) 444 6974

Milnerton Tel no (021) 400 6949

Melkbos Tel no (021) 444 7308

Atlantis Tel no (021) 444 4260

Brackenfell Tel No: 021) 417 0151

##### District East

Tel no (021) 444 9101 / 9112

Fax no (021) 953-0312

##### Fire Stations (Enquiries)

Belhar Tel no (021) 444 9111

Mfuleni Tel no (021) 444 4008

Strand Tel no (021) 444 7601

Somerset West Tel no (021) 444 2701

Khayelitsha Tel no (021) 444 8959

Kuilsriver Tel no (021) 400 3468

Macassar Tel No (021) 444 6790

Sir Lowry's Pass Tel No (021) 814 1360

##### District South

Tel no (021) 444 1669 / 1671

##### Fire Stations (Enquiries)

Lakeside Tel no (021) 444 1674

Fish Hoek Tel no (021) 400 7111

Simonstown Tel no (021) 400 3908

Ottery Tel no (021) 444 3500

Mitchells Plain Tel no (021) 444 3085

Gugulethu Tel no (021) 444 5481

Lansdowne Tel no (021) 444 0438

Kommetjie Road Tel No (021) 444 0111

##### Logistics & Planning:

Tel no (021) 444 0392

##### Finance:

Tel no (021) 590-1731

Fax no 086 576 0691

Cell no 084 220 0209

*Billing:* Tel no (021) 590-1744

#### STATISTICS

*Emergency Incidents:2020 - Fire Related:*17948 - Special

Service:8798

*Area of coverage:* 2455 sq kms

*Population:* R 4 000 00.00

#### DRAKENSTEIN LOCAL MUNICIPALITY FIRE & RESCUE

##### AREAS UNDER CONTROL

Paarl

##### CONTACT INFORMATION

Berg River Boulevard Paarl

PO Box 1 Paarl 7620

Switchboard Tel no (021) 807-4500 /4799

Fire Tel no (021) 872-1404 /4853 Fax no (021) 872 8054

Emergency Tel no (021) 872-2323

#### STATISTICS

*Size of area:* 1537 sq kms

*Population:* 186 188

*Value of area protecting:* R35 000 000.00

#### GARDEN ROUTE DISTRICT MUNICIPALITY

##### AREAS UNDER CONTROL

George LM, Knysna LM, Mossel Bay LM, Oudtshoorn LM, Bitou

LM, Kannaland LM, Hessequa LM)

##### CONTACT INFORMATION

54 York Street, George

PO Box 12 George 6530

Tel no (044) 803-1300 Fax no 086-614-4228

Email: info@gardenroute.gov.za

Emergency communications: (044) 805 5071 (24/7 availability)

##### Executive Mayor:

Tel no (044) 803 1301

##### Municipal Manager:

Tel no (044) 803-1300

##### Communications:

Email: communications@gardenroute.gov.za

##### Fire Services:

Email: firechief@gardenroute.gov.za

Email: emergency@gardenroute.gov.za

#### STATISTICS

*Size of area:* 23 323 sq kms

*Population:* ±613 124

*Fire stations:* 3

#### GEORGE LOCAL MUNICIPALITY FIRE DEPARTMENT COMMUNITY SERVICES

##### AREAS UNDER CONTROL

George, Wilderness, Harolds Bay, Uniondale

##### CONTACT INFORMATION

Mitchell Str George

PO Box 19 George 6530

Tel no (044) 801 6300 / 6377

Emergency no 084 014 1828

##### Municipal Management:

Tel no (044) 801 9069 / 6382

##### Law Enforcement:

Tel no (044) 801-6350

#### STATISTICS

*Size of area:* 5190.43 sq kms

*Population:* 220 000

*Value of area protecting:* R 946 000 000.00

#### HESSEQUA LOCAL MUNICIPALITY FIRE AND RESCUE SERVICES

##### AREAS UNDER CONTROL

Riversdal, Albertinia, Stilbaai, Heidelberg, CP Witsand,

Jongensfontein, Melkhoutfontein, Gouritzmond & Slangrivier

##### CONTACT INFORMATION

Van den Berg Str Riversdal

PO Box 29 Riversdal 6770

Tel no (028) 713-7817 / 8000 Fax no 086 4015 118

##### Municipal Management:

Tel no (028) 713-8001

Email: mm@hessequa.gov.za

##### Community Services:

Tel no (028) 713-8015

##### Department Protection Services:

Mulder Street, Riversdale Industrial

##### Manager Protection Services:

Tel no (028) 713 7817 / 7822

#### STATISTICS

*Size of area:* 54000 sq kms

*Value of area protecting:* R80 000 000.00

#### KNYSNA LOCAL MUNICIPALITY FIRE DEPARTMENT

##### AREAS UNDER CONTROL

Knysna, Knoetzie, Rheenedal, Karatara, Sedgefield, Buffelsbaai,

Jodenskal

##### CONTACT INFORMATION

35 Waterfront Rd Knysna

PO Box 21 Knysna 6

*Fire Services:*  
Tel no (044) 302 8911 / 8907

*Disaster Management:*  
Tel no (044) 302 6426

*Traffic:*  
Tel no (044) 3026551

*Regional Commander:*  
Tel no: 060 998 7046

**STATISTICS**

*Size of area:* 1059 sq kms

*Population:* 74 979

*Fire stations:* Knysna, Sedgfield substation, Joodsekamp substation

**LANGEBERG MUNICIPALITY**

**AREAS UNDER CONTROL**

Ashton, Bonnievale, McGregor, Montagu, Robertson

**CONTACT INFORMATION**

28 Main Rd Ashton  
Private Bag X2 Ashton 6715  
Tel no (023) 615-8000 Fax no (023) 615-1563  
Email: admin@langeberg.gov.za

*Municipal Management:*

Email: mm@langeberg.gov.za

**STATISTICS**

*Population:* 67 737

*Size of area:* 3335,3 sq kms

**SUB STATION**

*Montagu sub-station*  
Piet Retief Str Montagu  
Private Bag X2 Ashton 6715  
Tel no (023) 614-8000 Fax no (023) 614-1841

**MATZIKAMA LOCAL MUNICIPALITY**

**AREAS UNDER CONTROL**

Vredendal, Van Rhynsdorp, Klaver, Doringbaai, Strandfontein, Ebenhaezer, Koekenaap

**CONTACT INFORMATION**

37 Kerk Str Vredendal  
PO Box 98 Vredendal 8160  
Tel no (027) 201-3300 Fax no (027) 213-3238

*Municipal Management:*

Tel no (027) 201 3301 Fax no (027) 213 1504

**STATISTICS**

*Size of area:* ± 5500 sq kms

*Population:* ± 55 000

**SUB STATIONS / OFFICES**

*Klaver Office:* Tel no (027) 201 3423 / 4  
*Lutzville Office:* Tel no (027) 201 3441 / 3444  
*Van Rhynsdorp Office:* Tel no (027) 201 3431 / 2  
*Ebenhaezer Office:* Tel no (027) 201 3446/7  
*Doringbaai Office:* Tel no (027) 201 3445  
*Bitterfontein Office:* Tel no (027) 201 3484  
*Strandfontein Office:* Tel no (027) 201 3437  
*Koekenaap Office:* Tel no (027) 201 3440  
*Nuwerus Office:* Tel no (027) 201 3485  
*Kliprand Office:* Tel no (027) 501 1095  
*Molsvele Office:* Tel no (027) 632 5076  
*Rietpoort Office:* Tel no (027) 632 5013  
*Stofkraal Office:* Tel no (027) 632 5291

**MOSSSEL BAY LOCAL MUNICIPALITY FIRE, RESCUE & DISASTER MANAGEMENT SERVICES**

**AREAS UNDER CONTROL**

Mossel Bay, Great Brak River

**CONTACT INFORMATION**

PO Box 25 Mossel Bay 6500  
Tel no (044) 606-5107 / 606 5121  
Emergency no (044) 691-3722

*SAPS Dagamaskop Cluster:*

Tel no (044) 606 2800 / 2200/ 5600

*Traffic, Community Safety:*

Tel no (044) 606 5102

*Community Services:*

Tel no (044) 606 5000

*Fire Services:*

Tel no (044) 606 5035/6

*Disaster Management:*

Tel no (044) 691-1911

*WC Provincial Ambulance Services:*

Tel no (044) 691-1911

**STATISTICS**

*Size of area:* 2 700 sq kms

*Population:* ± 99 319

**FIRE STATIONS / HOUSES**

*Main Fire Station: Mossel Bay Fire Station*  
c/o Louis Fourie Road & Schoeman Street, Mossel Bay,  
Tel no (044) 606 5107 / 606 5121

*Fire House:* Great Brak River sub-station

Charles Str, Great Brak River 6525

Tel no (044) 606 5235

**OUDTSHOORN LOCAL MUNICIPALITY FIRE STATION**

**AREAS UNDER CONTROL**

Oudtshoorn

**CONTACT INFORMATION**

*Fire Brigade Office:* 26 Church Str Oudtshoorn  
*Oudtshoorn Municipality:* Cnr Voortrekker & Langhoven Sts,  
Oudtshoorn, 6625  
PO Box 255 Oudtshoorn 6620  
Tel no (044) 203-7800 After hours Tel no (044) 203 3133  
Emergency Tel no: (044) 203 7800

*Municipal Management:*

Tel no (044) 203 3004

Email: mm@oudtmun.gov.za

*Fire, Rescue and Disaster Management Services:*

Tel no (044) 203 7800

*Traffic:* Tel no (044) 272-4197

**STATISTICS**

*Size of area:* ± 3535 sq kms

*Population:* ± 100 000

**OVERBERG DISTRICT MUNICIPALITY FIRE AND RESCUE GREATER OVERBERG FIRE PROTECTION ASSOCIATION**

**AREAS UNDER CONTROL**

Theewaterskloof, Swellendam, Cape Agulhas, Caledon

**CONTACT INFORMATION**

22 Long Street Bredasdorp  
Private Bag X22 Bredasdorp 7280

*Fire & Disaster Management:*

Tel no (028) 425 1157 / 1690 Fax no 086 661 6067

**SUB DISTRICTS**

*Bredasdorp Sub District*

Tel no (028) 425 1157 Fax no 086 661 6067

Emergency calls tel no (028) 425 1690

*Grabouw Sub District*

Tel no (021) 859 5525 Fax no 086 506 3737

Emergency calls tel no (028) 425 1690

*Caledon Sub District*

Tel no (028) 212 3727

Emergency calls tel no (028) 425 1690

*Swellendam Sub District*

Tel no (028) 514 3980/90

Emergency calls tel no (028) 425 1690

*Theewaterskloof:*

6 Plein Str Caledon

PO Box 24 Caledon 7320

Tel no (028) 214-3300 Fax no (028) 214-1289

*Size of area:* 3 231 sq kms

*Population:* 108 790

*Villiersdorp Sub District*

Tel no (028) 840 0305

Emergency calls tel no (028) 425 1690

**OVERSTRAND LOCAL MUNICIPALITY**

**AREAS UNDER CONTROL**

Gansbaai, Hermanus, Stanford, Kleinmond

**CONTACT INFORMATION**

Magnolia Ave Hermanus  
PO Box 20 Hermanus 7200  
Fire Brigade 24 hrs switchboard Tel no (028) 313 8980  
Tel no emergencies (028) 312 2400

*Municipal Management:*

Tel no (028) 313 8003

*Protection Services:*

Tel no (028) 313-8054

*Fire Services:*

Tel no (028) 313 5041

**STATISTICS**

*Size of area:* ± 1708 sq kms

*Population:* ± 104 748

*Fire stations:* 3

**SALDANHA BAY LOCAL MUNICIPALITY**

**AREAS UNDER CONTROL**

Vredenburg, Saldanha, Paternoster, St Helena Bay, Hopefield, Langebaan, Jacobs Bay

**CONTACT INFORMATION**

12 Main Str Vredenburg, 7380  
Private Bag X12 Vredenburg 7380  
Switchboard: 022-701-7000  
Fax no (022) 715-1518  
24 hour Call Centre for fires: (022) 701 7061 / 713 1518 / 10177

*Municipal Management:*

Tel no (022) 701-7098

Email: mun@sbm.gov.za

*Traffic and Law Enforcement:*

Tel no (022) 701 6900

**STATISTICS**

*Size of area:* 2015 km²

*Population:* 99 193 (2011 Census)

Fire station: Cederburg

**STELLENBOSCH LOCAL MUNICIPALITY FIRE AND RESCUE SERVICES**

**AREAS UNDER CONTROL**

Stellenbosch

**CONTACT INFORMATION**

Cluver Str Stellenbosch  
PO Box 17 Stellenbosch 7599  
Municipality Tel no (021) 808 8111 / (021) 808 8878

*Municipal Management:*

Municipal.manager@stellenbosch.gov.za

Tel no (021)808 8025

*Fire Services:*

Tel no (021) 808-8890

**SWARTLAND LOCAL MUNICIPAL FIRE & EMERGENCY SERVICES**

**AREAS UNDER CONTROL**

Malmesbury, Moorreesburg, Riebeeck West, Riebeeck Kasteel, Darling, Yzerfontein, Koringberg, Valley Area

**CONTACT INFORMATION**

*Main Station Malmesbury:*  
Traffic Office Address: Piketberg Str Malmesbury  
Municipality Address: Church Street, Malmerbury  
Private Bag X52 Malmesbury, 7299  
Emergency no (022) 487 9400 / 082 566 0703  
Tel no (022) 487-9400 Fax no (022) 487-9440

**STATISTICS**

*Size of area:* 3700 sq kms

*Population:* 133 762

*Fire stations:* 7

**SUB-STATIONS**

*Darling Sub Station*  
Tel no (022) 492-2237  
Tel no after hours (022) 487 9400

*Malmesbury Station*

Tel no (022) 487 9400 / Tel no after hours (022) 487 9400

*Moorreesburg Sub station*

Tel no (022) 433-2246 / Tel no after hours (022) 487 9400

*Riebeeck Valley sub-station*

Tel no (022) 448-1258 / Tel no after hours (022) 487 9400

*Yzerfontein Sub Station*

Tel no (022) 451-2366 / Tel no after hours (022) 487 9400

**SWELLENDAM LOCAL MUNICIPALITY**

**AREAS UNDER CONTROL**

Swellendam

**CONTACT INFORMATION**

49 Voortrek Str Swellendam PO Box 20 Swellendam 6740  
Tel no (028) 514-8500 / 8529

**WEST COAST DISTRICT MUNICIPALITY**

**AREAS UNDER CONTROL**

Matzikama, Cederberg, Bergrivier, Saldanha Bay, Swartland

**CONTACT INFORMATION**

58 Long Street Moorreesburg 7310  
PO Box 242 Moorreesburg 7310  
Website: www.westcoastdm.co.za  
Email: records@swellenmun.co.za  
Tel no (022) 433-8400 Fax no (022) 433-8484 / 086 692 6113

*Municipal Management:*

Tel no (022) 433 8410

Email: mm@wcdm.co.za

*Administration and Community Services:*

Tel: 022 433 8410

*Fire Services:*

Tel no (022) 433 8702 / 8700 Fax no (022) 433-8875

#### **FIRE STATIONS**

*Piketberg Fire Station*

Reiger Street, Piketberg

Tel no (022) 913 3315

Email: piketbergfire@gmail.com

*Vredendal Fire Station*

Sirkeleet Street, Vredendal

Tel no (027) 213 1428

Email: vredendalfire@gmail.com

*Disaster Management:*

Tel no (027) 201-3411 Fax no 086-645-1487

#### **STATISTICS**

*Size of area protecting:* 31 099 sq kms - Matzikama: 12,891 -

Cederberg: 8,000 - Bergrivier: 4,407 - Saldanha Bay: 2,015 -

Swartland: 3,707

*Population total:* 391 766 - Matzikama: 67,147 - Cederberg: 49,768

- Bergrivier: 61,897 - Saldanha Bay: 99,193 - Swartland: 113,762

#### **WITZENBERG MUNICIPALITY PROTECTION SERVICES**

##### **AREAS UNDER CONTROL**

Ceres, Prince Alfred, Hamlet, Op Die Berg, Tulbagh, Wolseley

#### **CONTACT INFORMATION**

Pine Forest Resort, Carson Str Ceres

PO Box 44 Ceres 6835

Tel no (023) 316-8196 Fax no (023) 316-1877

Emergency number (023) 316-1997/8

Email: admin@witzenberg.gov.za

*Municipal Management:*

Tel no (023) 316-1854 Fax no (023) 316-1877

*Fire & Disaster Management Services:*

Tel no (023) 316 1854

#### **STATISTICS**

*Size of area:* 2851 sq kms

*Population:* ± 83 566

*Fire stations:* 4 satellite fire stations (Wosley, Tulbagh, Prince

Alfred's Hamlet, Op Die Berg)

#### **SUB STATIONS**

*Wolseley sub-station*

Voor trekker Str Wolseley

PO Box 44 Ceres 6835

Tel no (023) 316 1854 Fax no 023 316 1877

*Ceres sub-station*

Carson Street Ceres

*Tulbagh sub-station*

Tel no (023) 316-1854

*Prince Alfred's Hamlet*

Tel no (023) 313-3133

#### **Airports Training Academy**

New Operations Building, Gate 14 Bonaero Drive, Bonaero Park

PO Box 75480 Gardenview 2008

*Technical Training:*

Tel no 011-921-6756 Fax no 011-921-6661

*ARFF Training:*

Tel no +27 10 207 2871

#### **ALGOABAY FIRE SERVICES CC**

##### **INDUSTRY**

Outsourcing of Fire Services

##### **CONTACT INFORMATION**

PO Box 6090 Port Elizabeth 6000

55 Gavin Drive, Scheepers Hoogte, Uitenhage

Head office Tel no: (041) 994 4220

www.algoabayfire.co.za

#### **ANGLO AMERICAN THERMAL COAL**

##### **INDUSTRY**

Mining Coal

##### **CONTACT INFORMATION**

PO Box 61587 Marshalltown 2017

Tel no (011) 638 2732 Fax no (011) 638 2645

*Safety and Risk:*

Tel no (013) 691 5220

#### **ANGLO AMERICAN COAL MOZAMBIQUE INTERNATIONAL**

##### **INDUSTRY**

Mining

##### **CONTACT INFORMATION**

Comandante Moura Braz Rua No 27 R/c Maputo

Tel no 00258 21 403142 Fax no 00258 21 403144

#### **ANGLO AMERICAN KUMBA IRON ORE MINE**

##### **INDUSTRY**

Sishen Iron Ore Mine

##### **CONTACT INFORMATION**

Hendrik van Eck St, Kathu

Private Bag X506 Kathu 8446

Tel no (053) 739-2911 Fax no (053) 739-2000

*Fire Prevention:*

Tel no (053) 739-2222

*Emergency Response:*

Tel no (053) 739-2111

*Personnel:* 24 fire fighters, 4 senior firefighters

#### **ANGLO AMERICAN OPERATIONS LIMITED**

##### **INDUSTRY**

Mining

##### **CONTACT INFORMATION**

21 Main St, Postmasburg, 8420

Tel no (053) 313 9016

#### **ANGLO AMERICAN THERMAL COAL - NEW VAAL COLLIERY**

##### **INDUSTRY**

Coal Mining

##### **CONTACT INFORMATION**

New Denmark Colliery

Private Bag x 2022 Standerton, 2430

Tel no (017) 749 0902 / 0109

*Personnel:* 35 volunteer firemen, 1 doctor, 3 nurses

#### **ANGLOGOLD ASHANTI LIMITED**

##### **INDUSTRY**

Mining

##### **CONTACT INFORMATION**

PostNet Suite 1051 Private Bag X1007 Lyttelton 0140

Tel no 011 637 6736 Fax: 086 619 2018

##### **Moab Khotsong Mine**

PO Box 8044 Western Levels 2501

Tel no (018) 478-1983

##### **Tau Lekoa Mine**

Private Bag X800 Stilfontein

Tel no (018) 473-7063

*SHE Department:*

Tel no (018) 473-7057

#### **ASSMANG (PTY) LTD**

##### **INDUSTRY**

Iron ore opencast mining

##### **CONTACT INFORMATION**

PO Box 187 Santoy 8491

Tel no (053) 751 5227/4071

#### **ASSMANG IRON ORE**

##### **INDUSTRY**

Iron ore mining

##### **CONTACT INFORMATION**

Private Bag X503 Kathu 8446

Tel no (053) 723 8021 Fax no (053) 311 4310 / 086-650 6317

#### **BARPLATS MINE LTD**

##### **INDUSTRY**

Platinum mining

##### **CONTACT INFORMATION**

Old Zandfontein Road Brits, 0250,

PO Box 513 Brits 0250

Tel no (012) 381-1800 Fax no (012) 381-1893

*Fire Safety:*

Tel no (012) 381-1800

*Mine Rescue Service:*

Tel no (012) 381 1800

*Operations:*

Tel no (012) 3811840

#### **BHP BILLITON (PTY) LTD (SOUTH 32) - HOTAZEL MANGANESE MINES**

##### **INDUSTRY**

Manganese Mining

##### **CONTACT INFORMATION**

PO Box 1 Hotazel 8490

Tel no (053) 742-2481

#### **BHP BILLITON (SOUTH 32) ENERGY COAL SOUTH AFRICA**

##### **INDUSTRY**

Coal Mining

##### **CONTACT INFORMATION**

PO Box 12162 Leraatsfontein Emalahleni 1038

*Health and safety:*

Tel no (013) 689 4047

## INDUSTRIAL FIRE SERVICES

#### **AFRICAN RAINBOW MINERALS /ARM COAL**

##### **INDUSTRY**

Mining

##### **CONTACT INFORMATION**

ARM House, 29 Impala Rd, Chislehurst, Sandton

PO Box 786136 Sandton 2146

Admin Tel no: (011) 779 1300

*Procurement:*

Tel no: (011) 779 1000

*SHEQ Management:*

Tel no: (011) 779 1000

#### **AIRPORTS COMPANY SOUTH AFRICA SOC LIMITED**

##### **CONTACT INFORMATION**

PO Box 75480 Gardenview 2047

Tel no (011) 921 6242 Fax no (011) 453-9354

*Occupational Health & Safety:*

Tel no (011) 921 6242

##### **Bram Fischer International Airport Fire Department**

Airport Tel: (051) 407 2200

Tel no Manager Airfield - (051) 407-2221

*Fire & Rescue:*

Tel no (051) 407-2217 Fax no 0866072779

Private Bag X20562 Bloemfontein 9300

*Airfield Services:*

Tel no 051 407 2221

##### **Cape Town International Airport Fire Department**

Private Bag x1, Suite 57, Brackenfell, 7561

Tel no (021) 937-1211 / 1249 Fax no 086 607 6347

*Airfield Services:*

Tel no (021) 937-1249

*Training services:*

Tel no (021) 937 1365

##### **King Phalo Airport**

Tel no (043) 706-0314 Apron Office Tel no (043) 706 0311

Fax no 043-706-0313

##### **George Airport Fire Department**

Tel no (044) 876-9310 Fax 044 876 9027

PO Box 10000 George 6530

*Fire and Rescue:*

Tel no (044) 876 9310

##### **Kimberley Airport Fire Department**

Tel no (053)830-7107 Fax no (053) 851-7110

Private Bag X5052 Kimberley 8300

##### **King Shaka International Airport Fire Department**

PO Box 57701, King Shaka International Airport, 4407

Tel no (032) 436 7175 / 6722

*Fire & Rescue Training Officer:*

Tel no 032 436 4968

##### **OR Tambo International Airport Fire Department**

Private Bag X1 OR Tambo International Airport 1627

Tel no (011) 921 6596 / (011) 921-6598 Fax no 086 607 1724

##### **Pilanisberg International Airport Fire Department**

Peter Wagner Ave Mogwase

Private Bag X1016 Mogwase 0314

Tel no (014) 552-1261

##### **Port Elizabeth Airport Fire Department**

PO Box 5787 Walmer 6065

Tel no (041) 507-7314/5

*Fire Services:*

Tel no (041) 507-7323 Fax no (041) 507- 7358

##### **Upington International Airport Fire Department**

Tel no (054) 337 7900 Switchboard

Fire Dept Tel no (054) 337 7900 Fax no (054) 3326502

Private Bag X5936 Upington 8800

**BOMBELA OPERATING COMPANY****INDUSTRY**

Railway Operator

**CONTACT INFORMATION**PO Box 1309 Kelvin 2054  
Tel (011) 253 0026 Fax no (011) 253 0099**BP SOUTH AFRICA****INDUSTRY**

Refining fuels and lubricants

**CONTACT INFORMATION****BP Waterfront**  
Merchant House, Dock Rd, Portwood Ridge V&A Waterfront  
Cape Town 8000  
P O Box 50736 V&A Waterfront Cape Town 8002  
Tel no (021) 408-2911**BMW OF SOUTH AFRICA****INDUSTRY**

Vehicle assembly

*Emergency service supplied by Algoabay Fire Services***CONTACT INFORMATION**6 Frans du Toit Street, Rosslyn, Pretoria  
Tel no (012) 522 3000 Fax no (012) 522 2347*Algoabay Fire Services cc*

Tel no (041) 373 0335

**CHEVRON SOUTH AFRICA (PTY) LIMITED****INDUSTRY**

Petrochemical Refinery

**CONTACT INFORMATION**Platteklouf Rd Milnerton  
PO Box 13 Milnerton 7435  
Tel no (021) 508-3911*Fire Service:*

Tel no (021) 508 3445 / 3308

*Safety and Health:*

Tel no (021) 508 3296 / 3445 / 021 403 7911

*Fire Protection:*

Tel no (021) 508 3428

*Fire Training:*

Tel no (021) 508 3911

**DE BEERS CONSOLIDATED MINES****INDUSTRY**

Diamond Mining

**CONTACT INFORMATION****Venetia Diamond Mine**  
1 National Road, Musina PO Box 668 Musina 0900  
Tel no (015) 575 2054*Mine Safety:*

Tel no (015) 575 2710 / 2104

*Fire Service:*

Tel no (015) 575-2054 Fax: 015-575-2043

**Finsch Mine**

PO Box 7 Lime Acres 8410

*Fire Safety & ER24:*

Tel no (053) 385-2513

**DENEL INDUSTRIAL PROPERTIES - KEMPTON PARK CAMPUS****INDUSTRY**

Property Management

**CONTACT INFORMATION**PO Box 15504 Impala Park 1472  
*Fire Service:*  
Tel no (011) 927-2345 / 2338 Fax no (011) 927-2345  
Email: firedepartment@denprop.co.za**DUNLOP INDUSTRIAL PRODUCTS****(Industrial Products Division)****INDUSTRY**

Manufacturer conveyor belts, automotive components, rubber

**CONTACT INFORMATION**Induna Mills Rd Howick  
PO Box 29 Howick 3290  
Tel no (033) 239-7200 Fax no (033) 239 7291**ENGEN PETROLEUM LIMITED****INDUSTRY**

Sale of petroleum products

**CONTACT INFORMATION****Durban**  
171 Blairatholl Rd Westville  
PO Box 136 Durban 4060  
Tel no Head Office: (021) 403-4911 / (031) 250-2911  
Fax no (031) 250-2929*Training Division:*

Tel no (031) 250 2911

*Personnel:* 5 person proto-team fire fighter**Cape Town**PO Box 35 Cape Town 8000  
Tel no (021) 403 4911 / 4155 Fax no (021) 403 4067**ENGEN REFINERY****A division of Engen Petroleum Limited****INDUSTRY**

Oil refining

**CONTACT INFORMATION**465 Tara Rd Wentworth Durban  
PO Box 956 Durban 4000  
Tel no (031) 460-3302 Fax no (031) 460-3213*Emergency Response:*

Tel no 031 460 2409

**ESKOM****INDUSTRY**

Power Generation

**CONTACT INFORMATION****Eskom Megawatt Park Fire Risk and Emergency Management**  
PO Box 1091 Johannesburg 2000  
Tel no (011) 897 6285 / 800-5390 Fax no 086 536 5373*Kendal Power station*

Private Bag X7272 Witbank 1035

*Kriel Power Station*

Private Bag X5009 Kriel 2271

Tel no (017) 615 -2399

*Koeberg Nuclear Power Station*

Private Bag X10 Kernkrag 7440

Tel no (021) 550-4610

*Komati Power Station*

Private Bag Blinkpan 2250

Tel no (013) 295-9497

*Lethabo Power Station*

Private Bag x415 Viljoensdrift 1930

Tel no (016) 457-5518

*Majuba Power Station*

Private Bag 9001 Volksrust 2470

Tel no (017) 799-3192

*Matimba Power Station*

Private Bag x215 Lephalele 0555

Tel no (014) 763-8423

*Matla Power Station*

Private Bag X5012 Kriel 2271

Tel no (017) 612-6627

*Arnot Power Station*

Private Bag X2 Rietkuil 1097

Tel no (013) 297-9099

*Camden Power Station*

Private Bag X1002 Nucam 2355

Tel no (017) 827 3064

*Tutuka Power Station*

Private Bag X2016 Standerton 2430

Tel no (017) 749-5954

*Duvha Power Station*

PO Box 2199 Witbank 1035

Tel no (013) 690-0111

*Grootvlei Power Station*

Private Bag Eskom Grootvlei 2420

Tel no (017) 779 8594

*Hendrina Power Station*

Private Bag X1003 Puller's Hope 1096

*Kusile Power Station*

Tel no (013) 680 3051

*Medupi Power Station*

Tel no (014) 762 6752

**FINE CHEMICALS CORP (PTY) LTD****INDUSTRY**

Manufacturer Active Pharmaceutical Ingredients

**CONTACT INFORMATION**15 Hawkins Ave Epping No 1  
PO Box 253 Eppindust 7460  
Tel no (021) 530 8100 Fax no (021) 531 1458  
Emergency Telephone no (021) 530 8130*OHSE Risk :* Tel: 021 530 8165**FOODCORP RCL FOOD CONSUMER (PTY) LTD****(A division of Foodcorp (Pty) Ltd)****INDUSTRY**

Grocery

**CONTACT INFORMATION**2 Desert Str Homelake  
PO Box 72 Randfontein 1760  
Tel no (011) 411-5400 / 5404 Fax no (011) 692-1665**FOREST FIRE ASSOCIATION - KISHUGU****INDUSTRY**

Government funded job creation programme for fire fighters

**CONTACT INFORMATION***Head Office:*  
1 Club Street Working on Fire / Kishugu Building Nelspruit Airfield  
Mpumalanga  
Tel (013) 741 6400*National Office:*Winter House, Kirsten Bosch Gardens Rhodes Avenue, Newlands,  
Cape Town 7700  
Tel no (021) 797-5787**FOSKOR LTD****INDUSTRY**

Mining

**CONTACT INFORMATION**27 Selati Rd, Phalaborwa  
PO Box 1 Phalaborwa 1390  
Tel no (015) 789-2000 Fax no (015) 789-2066*Training Officer:*

Tel no (015) 789 2345

**GLENCORE****INDUSTRY**

Manufacturer ferrochrome

**CONTACT INFORMATION**On the Ohrigstad Rd North of Lydenburg  
PO Box 195 Lydenburg 1120  
Tel no (013) 230-6000 Fax no (013) 230-6002**GOLD FIELDS LTD - SOUTH DEEP GOLD MINE****INDUSTRY**

Gold Mining

**CONTACT INFORMATION**

PO Box 776 Westonaria 1780

*Safety department:*

Tel no (011) 411 1768

*Emergency Response:*

Tel no (011) 411-1196

**GOODYEAR SOUTH AFRICA (PTY) LTD****INDUSTRY**

Tyre Manufacture

*Service supplied by Algoabay Fire Services cc***CONTACT INFORMATION**Algoa Road Alexander Park Industrial Uitenhage  
PO Box 126 Uitenhage 6230  
Tel no (041) 994 6290 / 6681 Fax no (041) 992-6306**HARMONY GOLD MINING CO LTD****INDUSTRY**

Gold mine

**CONTACT INFORMATION**Cnr Ward & Main Reef Rd Randfontein  
PO Box 2 Randfontein 1760  
Tel no (011) 411-2000 / 2143 Fax no (011) 692 3879*Training:*

Tel no (011) 411 2060

**IDWALA INDUSTRIAL HOLDINGS****INDUSTRY**

Producer of lime and industrial minerals

**CONTACT INFORMATION***Head Office*  
Cnr Allandale &, Chloor Rd, Edenvale, 1622  
Tel no (011) 795-4900 / 8000 Fax no (011) 795-4923*SHEQ Department:*

Tel no 011 795 4900

***Idwala Lime****Danielskuil:* Ouplaas Factory Industrial Area Danielskuil 8405

PO Box 89 Danielskuil 8405

Tel no (053) 384 8599 Fax no (053) 384 0671

***Idwala Lime***Vereeniging: Cnr Kelvin and Rosherville Street Powerville Tel no  
(011) 795 4900 / (016) 455 1180

**Idwala Carbonates**  
Port Shepstone  
Tel no (039) 687-8000 Fax: (039) 687 8027

**Idwala Industrial Minerals**  
36 Commissioner street, Benoni Industrial Sites 1501  
P O Box 6056 Dunswart  
Tel: 011-914-2600 Fax: 011 914 1293

**Idwala Magnetite**  
C/o Foskor Mine Phalaborwa 1390  
P O Box 1914 Phalaborwa, 1390  
Tel no (015) 781-3736 / 5591 / (011) 795 4900 Fax: (015) 781 7789

**OMYA Idwala SA**  
Tel no (073) 338 8596

**IMPALA PLATINUM REFINERY SPRINGS**

**INDUSTRY**  
Platinum mining

**CONTACT INFORMATION**  
Cnr. East Geduld Road & Cowles Street, East Geduld, Springs, 1559  
P O Box 222 Springs, 1559  
*Safety & Environmental Management:*  
Tel: (011) 360 3164 Fax: (011) 360 3162

**IMPALA PLATINUM REFINERY (PTY) LTD**

**INDUSTRY**  
Platinum mining

**CONTACT INFORMATION**  
PO Box 222 Springs 1560  
Tel no (011) 360 3156 Fax no (011) 360 3062

**MALANDELA SECURITY SERVICES (PTY) LTD FIRE SERVICES G4 Security Services (Pty) Ltd**

**INDUSTRY**  
Security Services holiday resort

**CONTACT INFORMATION**  
Coastal Division Kwazulu Natal (Hotel & casino holiday resort)  
Old Main Rd Bizana  
PO Box 23 Port Edward 4295  
Tel no (039) 305-2931 Fax no 086 592 4673

*Fire/Security:*  
Tel no 039 305 2931 Fax no 086 592 4673

**MAVUNGWANI COLLIERY**

**INDUSTRY**  
Coal Mining

**CONTACT INFORMATION**  
Postnet Suit 1091, Private Bag X7297, Witbank, 1035  
Tel no (013) 656 3732/3733 Fax no (013) 656 3614

**MERCEDES BENZ SOUTH AFRICA LTD**

**INDUSTRY**  
Motor assembly

**CONTACT INFORMATION**  
Settlers Way East London  
PO Box 671 East London 5200

*Fire Service:*  
Tel no (043) 706-2018 / 2497  
Control Room Tel no (043) 706-2718

**MINE RESCUE SERVICES (PTY) LTD**

**INDUSTRY**  
Mining Rescue

**CONTACT INFORMATION**  
PO Box 1635 Carletonville 2500  
Tel no (018) 781-1141/2 Fax no (018) 781-1085  
After hours tel no: (018) 771 7617  
Emergency: 082 852 4053 / 082 334 0504  
Email: admin@minerescue.co.za

**MONDI INDUSTRIAL FIRE & EMERGENCY SERVICES**

**INDUSTRY**  
Paper Mill

**CONTACT INFORMATION**  
**Mondi Merebank**  
Shop 8, Dollar Drive, Alton, Richards Bay  
Tel (031) 451 2729 / (035) 789 0249

*Fire Service:*  
Tel no (031) 451 2702

**Richards Bay Mill (KZN)**  
7 Western Arterial, Alton, Richards Bay, 3900  
PO Box 1551, Richards Bay, 3900  
Tel no (035) 902-2730 Fax no (035) 902-2817

*Fire Operations & Fire Prevention:*  
Tel no (035) 902 2892

*Fire Officer Maintenance:*  
Tel no (035) 902 2540

**NATIONAL PETROLEUM REFINERS OF SOUTH AFRICA (PTY) LTD (NATREF)**

**INDUSTRY**  
Crude oil refiners

**CONTACT INFORMATION**  
Jan Haak Rd Sasolburg  
PO Box 234 Sasolburg 1947  
Tel no (016) 940-2782 / 2647 Fax no (016) 940-2775

**NECSA**

**INDUSTRY**  
Nuclear energy and radiation sciences R&D

**CONTACT INFORMATION**  
PO Box 582 Pretoria 0001  
Tel no (012) 305-3333 Fax no (012) 305-6362  
*Fire Service:*  
Tel no (012) 305-6003  
Email: fire@necsa.co.za

**NKOMATI MINE**

**INDUSTRY**  
Nickel Mining

**CONTACT INFORMATION**  
P O Box 562 Machadodorp, 1170  
Slaaihoek Farm 540JT, Waterval Boven District  
*Health & Hygiene Superintendent:*  
Tel no (013) 712 8200 Fax no (013) 712 8473

**NORTHAM PLATINUM LIMITED**

**INDUSTRY**  
Platinum mining

**CONTACT INFORMATION**  
Farm 384KQ Zondereinde 0380  
PO Box 441 Thabazimbi 0380  
Tel no (014) 784 3000 Fax no 086 572 8702  
*Safety / Fire Co-ordinator:*  
Tel no (014) 784-3179 Cell no 0711748575

**PETRA DIAMONDS**

**INDUSTRY**  
Diamond mining

**CONTACT INFORMATION**  
**Finch Mine**  
PO Box 7 Lime Acres 8410  
Tel no (053) 305 5122 Fax no (053) 305 5028

**PETROSA NATIONAL OIL**

**INDUSTRY**  
GTL Refinery

**CONTACT INFORMATION**  
*Head Office:*  
1 Protea Place Fredman Drive Sandton  
Tel no (011) 201-5800  
Email: petrosa@petrosa.co.za

*Mossel Bay:*  
Duinzicht Avenue Mossel Bay  
Private Bag X14 Mossel Bay 6500  
Tel no (044) 601-3161/ 8400 Emergency no (044) 601-2222

*Fire Service:*  
Tel no (044) 601-3403

*Training:*  
Tel no (044) 601-3160

*Occupational Safety / Fire:*  
Tel no (044) 601 3407 / 2911

*Cape Town:*  
Tel no (021) 929 3000 Fax no (021) 929 3144

**PIONEER FOODS**

**INDUSTRY**  
Wheat millers

**CONTACT INFORMATION**  
24 Nichol Str Chamdor Krugersdorp 1739  
PO Box 4315 Luipaardsvlei 1743  
Tel no (011) 271 7300

**PPC LIME LIMITED**

**INDUSTRY**  
Manufacturer lime

**CONTACT INFORMATION**  
Private Bag Lime Acres 8410  
*Risk Management:* Tel no (053) 385 8328  
*Training:* Tel no (053) 385 8227

**PUREGAS (PTY) LTD**

**INDUSTRY**  
Supplier of purified and blended gaseous hydrocarbon propellant, foam blowing products

**CONTACT INFORMATION**  
4 Liebenberg Street Alrode  
PO Box 123884 Alrode 1451  
Tel no (011) 903 9760 Fax no (011) 903 9766

**RICHARDS BAY COAL TERMINAL LTD**

**INDUSTRY**  
Coal exporting

**CONTACT INFORMATION**  
South Dunes Richards Bay  
PO Box 56 Richards Bay 3900  
Tel no (035) 904-4911 Fax no 086 632 8336  
*Safety / Fire Services:*  
Tel no (035) 904-4001 / 4102  
*Security & Emergency Preparedness:*  
Tel: 035 904 4000

*ETD Section Management:*  
Tel no (035) 904-4383 Fax no 086 632 8311

**ROSSING URANIUM LTD INTERNATIONAL (RIO TINTO GROUP)**

**INDUSTRY**  
Mining

**CONTACT INFORMATION**  
28 Hidipo Hamutenya Avenue,  
Private Bag 5005 Swakopmund Namibia  
Tel no 00264 64 5202272 Fax no 00264 64 5202281  
Website: www.riotinto.com

**ROYAL BAFOKENG PLATINUM**

**INDUSTRY**  
Platinum Mine

**CONTACT INFORMATION**  
Private Bag X82085 Rustenburg 0300  
*Safety / Fire:*  
Tel no (014) 573 1585 Fax no (014) 573 1585

**SAFRIPOL (PTY) LTD**

**INDUSTRY**  
Manufacturer plastic

**CONTACT INFORMATION**  
Eugene Houdry Str Northern Industry Sasolburg  
PO Box 700 Sasolburg 1947  
Tel no (016) 970- 4000/4001 Fax no (016) 970-4107

**SAMANCOR LTD**

**INDUSTRY**  
Manganese mine

**CONTACT INFORMATION**  
PO Box 3 Steelpoort, 1153  
*SHEQ Specialist - Ventilation:*  
Tel no (013) 230-7000 / 7121 Fax no 086 668 1227

**SAMANCOR EASTERN CHROME MINES**

**INDUSTRY**  
Chrome mine

**CONTACT INFORMATION**  
PO Box 2290 Burgersfort 1150  
*Sheq Administrator :*  
Tel no (011) 249 4408  
*SHEQ Specialist - Ventilation:*  
Tell no (013) 230-7121

**SAMUELS OIL****INDUSTRY**

Petroleum Products distribution

**CONTACT INFORMATION**

15 Crispa Rd, Cornubia Business Estate, Durban, 4015  
Postnet Suite 974 Private Bag X9013 Ermelo 2350  
Head Office tel no (031) 358 3200  
Email: info@samuels.co.za

**(SANRAL) SOUTH AFRICAN NATIONAL ROADS AGENCY LTD****INDUSTRY**

Roads maintenance

**CONTACT INFORMATION***Pretoria*

P O Box 415 Pretoria 0001  
Tel no (012) 844 8000

*Menlyn Office*

Private Bag X17 Lynnwood Ridge Pretoria 0040

*Safety / Fire Manager:*

Tel no (012) 426 6200

*Eastern Cape*

PO Box 27230 Greenacres Port Elizabeth 6000  
Tel no (041) 398 3200 Fax no (041) 492 0201

*Safety / Fire Administration:*

Tel: 041 398 3224

*Kwazulu Natal:*

P O Box 100410 Scottsville 3209  
Tel no (033) 392 8100

**SAPPI KRAFT****INDUSTRY**

Paper mill

**CONTACT INFORMATION***Stanger Mill*

PO Box 725 Stanger 4450  
Tel no (032) 437 2222 Fax no (032) 551-1622

*Risk Control:* Tel no (032) 437 2387*Tugela Mill*

Old Main Road Mandini 4490  
Private Bag x 6034 Mandini, 4490  
Tel no (032) 456-1111 Fax no (032) 456-1484

*Training:* Tel no (032) 279 6202*Ngodwana Mill*

Sappi Ngodwana, N4 Highway between Nelspruit & Waterval  
Boven 1209

Private Bag X1001 Ngodwana 1209

Switchboard No (013) 734 6239

Tel no (013) 734-6111 Fax no (013) 734-6535

*Fire Service:*

Tel: (013) 734 6222

*Training:*

Tel no (013) 734 6291 Fax no (013) 734 6535

**SAPREF - SHELL AND BP PETROLEUM REFINERIES (PTY) LTD****INDUSTRY**

Petrol and oil refiners

**CONTACT INFORMATION**

No. 1 Refinery Road Prospecton Durban, 4000  
PO Box 26312 Isipingo Beach, 4115  
Tel no (031) 480 1911

*Fire Department:*

Tel no (031) 480 1606 Fax no (031) 480 1126

Fax2Email: 086-241-5251

*Emergency Services:*

Tel no (031) 480 1031 /1501 / 1352

*Occupational health and safety:*

Tel no (031) 480 1911

**SASOL INFRACHEM****INDUSTRY**

Petrochemical

**CONTACT INFORMATION****SCI & Midland Sites**

Klasie Havenga St Sasolburg 1947

PO Box 1 Sasolburg, 1947

Tel no (016) 960-3048/9 Fax no (016) 960-2545

**SASOL MINING (PTY) LTD****INDUSTRY**

Coal Mining

**CONTACT INFORMATION**

Private Bag X1015 Secunda 2302

Tel no (017) 614 3268

**SASOL SECUNDA EMERGENCY MANAGEMENT SERVICES****INDUSTRY**

Integrated oil, gas, petrochemical and energy

**CONTACT INFORMATION**

Private Bag X1000 Secunda 2302

Tel no (017) 610-2478 /610-6211 Fax no (017) 610-4805

Emergency Toll free Sasol SA hazmat enquiries and incidents:  
0800 11 28 90

Landline Tel no (017) 610 4444

*Fire services:*

Tel no (017) 610-3827 Fax no (017) 522-6866

*Operations:*

Tel no (017) 610 4775

*Fire Engineering and preparedness:*

Tel (017) 610 2192

*Training Academy:*

Tell no (017) 610 8212

*Area of Designation:* Primary industrial area - 8,5 sqkm.*Total area of designation including mines:* 250 sqkm**SCAW METALS A DIVISION OF AMIC INDUSTRIES****INDUSTRY**

Foundries, engineering &amp; rolling mills

**CONTACT INFORMATION**

Blackreef Rd Dinwiddie Germiston

PO Box 61721 Marshalltown 2107

Tel (011) 842-9000 Fax no (011) 842-9719 / 9703

*Group Safety:* Tel (011) 842-9582**SIBANYE GOLD SHARED SERVICES****INDUSTRY**

Mining

**CONTACT INFORMATION**

Libanon Business Park 1 Hospital Rd Westonia 1780

Private Bag X2054 Carltonville 2500

Tel no (011) 278 9790 Fax no 086 520 0338

**SUN CITY FIRE & EMS DEPARTMENT****INDUSTRY**

Hotel and casino holiday resort

**CONTACT INFORMATION**

Sun City Complex South Village

Farm Doornhoek 910, District of Mankwe, NWP, 0316

PO Box 15 Sun City, 0316

Sun City Emergency and Security Control Room:

Tel no (014) 557 9111 / 1111 / 2 / 3 / 4 / 5

*Emergency Services:*

Tel no (014) 557 1116

*Fire Services:*

Tel no (014) 557 1727

*Health & Safety Compliance:*

Tel no (014) 557-1717

*Area protecting:* 28 829 sq kms (hotel industry), 22 258 (nature reserve), small industry 1 225*Population:* ± 50 000**TAU LEKOA GOLD MINE****INDUSTRY**

Gold Mining

**CONTACT INFORMATION**

Goedgenoeg Farm, 2619 Orkney, Northwest

Private Bag X800 Stilfontein 2550

Tel no (018) 473-7063

*Safety, health and environment:*

Tel no (018) 473-7057

**THE SOUTH AFRICAN BREWERIES MALTINGS****INDUSTRY**

Malting of barley for beer brewing purposes

**CONTACT INFORMATION****Member of AB Indev**

Bredasdorp Rd Caledon PO Box 27 Caledon 7230

Tel no (028) 214-3100 Fax no 086 646 7208

*Safety Management:* Tel no (028) 214 3232**TOTAL SOUTH AFRICA (PTY) LTD****INDUSTRY**

Manufacturers and sells petroleum and oil

**CONTACT INFORMATION****Head Quarters Gauteng**

3 Biermann Avenue, Rosebank

Tel no (011) 778-2000 / 2203 Fax no 086-680-5000

**Durban**

PO Box 21023 Bluff 4036

Tel no (031) 466 9440

**TRANSNET ENGINEERING****INDUSTRY**

A manufacturing and repair facility for locomotives, rolling stock, components, and container trailers

**CONTACT INFORMATION**

Head Office Pretoria: Kilner Park Pretoria

PO Box 4951 Durban 4000

311 Solomon Mahlangu Drive, Durban

(Major repair facilities at Koedoespoort, Germiston, Langlaagte, Uitenhague, Salt River)

*Fire coordinator:*

Tel no (031) 361-4087 Fax (031) 361-4163

**TRANSNET FREIGHT RAIL HAZMAT FIRE AND EMERGENCY MANAGEMENT - ENTERPRISE RISK MANAGEMENT****INDUSTRY**

Rail Transportation

**CONTACT INFORMATION****Corporate Office Johannesburg**

PO Box 31084 Braamfontein 2017

Tel no (011) 584- 0531

*Hazmat Fire and Emergency Management:*

Tel no (011) 584- 0532

*Dangerous Goods & Disaster Management:*

Tel no (011) 584 -0552

**Western Region**

Tel no (053) 838-3166

*Port Elizabeth HFES - Fire Station*

PO Box 324 Port Elizabeth 6000

Tel no (041) 507-4160 Fax no (041) 507-4161

*Western Cape Bellville HFES - Fire Station*

PO Box 811 Sanlamhof 7532 Caledon West Street Bellville

Tel no (021) 940-2961/940 2963 Fax no (021) 940-2983

*Western Cape Beaufort West - Fire Station*

Tel no (023) 449 2161

*Eastern Cape - East London HFES - Fire Station*

Tel no (043) 700 4333

**Northern Region***Northern Cape - Kimberley HFES - Fire Station*

PO Box 620 Kimberley 8300

Tel no (053) 838-3166 Fax no (053) 838 3059

*Free State Bloemfontein HFES - Fire Station*

PO Box 4413, Bloemfontein 9300

Tel no (051) 408 2000 Fax no (051) 408-4487

**Central Region**

Tel no (011) 570 7079

*Gauteng Sentra Rand HFES - Fire Station*

PO Box 8217 Putfontein 1513

Tel no (011) 960-2100 Fax no (011) 960-2555

*Gauteng Langlaagte HFES - Fire Station*

Tel no (011) 960 2300

*Free State Sasolburg HFES - Fire Station*

Tel no (016) 960 2300

*KZN - Pietermaritzburg HFES - Fire Station*

Tel no (033) 897 2243

*KZN - Durban HFES - Fire Station*

Tel no (033) 897 2243

*KZN - Ladysmith HFES - Fire Station*

Tel no (036) 271 2469/70

**Eastern region***Northern Kwazulu Natal Empangeni HFES - Fire Station*

PO Box 1299 Empangeni 3880

Tel no (035) 906-7378 Fax no (035) 906-7365

*Northern Kwazulu Natal - Vryheid HFES - Fire Station*

Tel no (043) 498 99521

*Mpumalanga - Ermelo HFES - Fire Station*

Tel no (017) 801 2315

*Northern Gauteng Pretoria HFES - Fire Station*

P O Box 637 Pretoria, 0001

Tel no (012) 315 8096 Cell no 083 379 0284

*Mpumalanga - Nelspruit HFES - Fire Station*

Tel no (013) 752 9484

*Limpopo- Polokwane HFES - Fire Station*

Tel no (015) 299 6393

**TRANSNET NATIONAL PORTS AUTHORITY OF SOUTH AFRICA - FIRE & EMERGENCY SERVICES****INDUSTRY**

Rail transport, port management

**CONTACT INFORMATION****Port of Durban TNPA**

Fire Department, Pier 1, 980 Bayhead Rd Durban 4000

PO Box 1027 Durban 4000

Tel no (031) 361-6560 Emergency (031) 361- 6333

Island View Office Tel no (031) 361-6463 Fax (031) 361-6772

*Fire Service:*

Tel no (031) 361 6548 / 6441 Fax no (031) 361 6439

*Area protecting:* Port of Durban*Population:* Approx 12 000**Port of Richards Bay TNPA Fire & Emergency Services**

PO Box 181 Richards Bay 3900

Tel no (035) 905-3335 / 3135 / 3072

Emergency no (035) 905 4111 Standby Cell no 083 708 0830

*Fire Service:*

Tel no (035) 905 3135

*Training:*

Tel no (035) 905 3194

**Port Elizabeth TNPA Fire & Emergency Services**

PO Box 324 Port Elizabeth 6001

Switchboard tel no (041)507 4160/4162

Control Office tel no (041) 507 4160/4162

Fax no (041) 507 4161

*Fire Service:*

Tel no (041) 507-4160 Fax no (041) 507-4161

*Training:*

Tel no (041) 507 1914 Fax no (041) 507 1904

**Port of Saldanha TNPA Fire & Emergency Services**

Private Bag X1 National Ports Authority, Saldanha 7395

Tel no (022) 703-4338 Fax no (022) 703-4403

Standby cell: 073 185 7205

*Fire Service:*

Tel no (022) 703 4330 / 5427

**Port of Cape Town TNPA Fire & Emergency Services**

PO Box 4245 Cape Town 8000

Switchboard Tel no (021) 449 3901 / 5848 Fax no (021) 449 3973

*Fire Service:*

Tel no (021) 449- 5804

**VIRGINIA AIRPORT****INDUSTRY**

Airport, Air transport

**CONTACT INFORMATION**

220 Fairway Durban North

PO Box 201444 Durban North 4016

Tel no (031) 563-7101 Fax no (031) 563-7138

*Personnel:* 3 fire fighters per shift (2 shifts)***Richards Bay Airport***

Fish Eagle Flight Richards Bay 3900

Suite 75 P/Bag X1040 Richards Bay 3900

Tel no (035) 786 0119 / (035) 789 9630 Fax no (035) 786 0296

***Indiza Fire and Training Services***

Stoneridge Office Park, 08 Greenstone Place, Greenstone Hill,

Edenvale, 1609 PO Box 55389 Northlands 2116

Tel no (011) 524 8400 Fax no (011) 524 8498

*Durban Branch:*

Tel no: (035) 789 9630

**VOLKSWAGEN SOUTH AFRICA****INDUSTRY**

Vehicle assembly

**CONTACT INFORMATION***Service supplied by Algoabay Fire Services cc*

Tel no (041) 994 4333 / 5615 / 996 6003

**WALTER SISULU UNIVERSITY****INDUSTRY**

University Campus

**CONTACT INFORMATION**

Nelson Mandela Drive Mthatha 5100

Private Bag X1 Mthatha 5100

Tel no (047) 502-2517 Fax no 086 733 8024

*Fire Service:*

Tel no (047) 502-2517

**WATERBERG FIRE & RESCUE****INDUSTRY**

Rescue services

**CONTACT INFORMATION**

Corner Oktaan &amp; Nelson Mandela Drive, Industrial Site, Modimolle

PO Box 700 Vaalwater 0530

Tel no 082 807 8152 / 0800 111 660 Fax no (014) 755-4080

Control Centre: 082 807 8152

Ambulance: (014) 718 3800

*Size of area:* ± 2500 sq kms*Population:* ± 1000**WATER AFFAIRS AND FORESTRY DEPARTMENT****INDUSTRY**

Government management of water and forestry

**CONTACT INFORMATION***National*

Switchboard: (012) 336 7500 Fax no (012) 326-8850

Email: centralp@dws.gov.za

*Central Information:*

Tel no (012) 336 8701 Fax no (012) 336 7321

*Communications:*

Tel no (012) 336 7908 Cell no 079 316 9648

*Spokesperson:*

Tel no (012) 336 6813

*Deputy Minister's office:*

Tel no (012) 336 6885

**Eastern Cape***Department of Water and Sanitation*

2 Hargreaves Ave, King Williams Town

Private Bag X7485 King Williams Town 5600

Tel no (043) 604-5400 Fax no (043) 642 6032

*Port Elizabeth*

Lion Roars Office Park Building, 50 Heugh Road, Walmer, 6070

PO Box 5501 Walmer, 6065

*Southern Operations (NWR) National Water Resource**Infrastructure:*

Tel no (041) 501 0740

*Training:*

Tel no (043) 604 5400

**Free State***Department of Water and Sanitation*

2nd Floor, Bloem Plaza, Cnr Charlotte Maxeke &amp; East Burger Sts,

Bloemfontein

PO Box 528 Bloemfontein 9300

Tel no (051) 405-9000 Fax no (051) 430-8146

**Gauteng***Department of Water and Sanitation*

15th Floor, Bothongo Plaza East Building, 285 Francis Baard St

Pretoria, Private Bag x 995 Pretoria, 0001

Tel no (012) 392-1300/1301 Fax no 086 274 3717

**KwaZulu-Natal***Department of Agriculture, Forestry and Fisheries*

185 Langalibalele St, Pietermaritzburg

Private Bag X9029 Pietermaritzburg 3200

Tel no (033) 392 7700 Fax no (033) 345-1210 / 086 650 0747

Chief Director: Eva Diphare

*Training:*

Tel no (033) 392 7777 Fax no 086 238 9992

**Limpopo***Department of Water and Sanitation*

Azmo Place, 49 Joubert St, Polokwane, 0700

Private Bag X9506 Polokwane, 0700

Tel no (015) 290-1200 / 1208 Fax no (015) 290 2295

**Mpumalanga***Department of Water Sanitation*

Prorom Bld, Cnr Brown &amp; Paul Kruger Sts, Nelspruit

Private Bag X11259 Nelspruit 1200

Tel no (013)759-7300 / 7586 Fax no (013) 759-7525

*Training:*

Tel no (013)759-7338

*Operations Corporate Services:*

Tel no (013) 759-7302

**North West***Department of Water and Sanitation*

99 Ground Floor, Mega City Shopping Centre, Corner Dr James

Moroka Drive &amp; Sekame Road, Mmabatho

Private Bag X5 Mmabatho 2735

Tel no (018) 387 9500 Fax no (018) 392-2998

*Training:*

Tel no (018) 387 9590

**Northern Cape***Water Affairs and Sanitation Department*

28 Central Rd, Beaconsfield, Kimberley

Private Bag X6101 Kimberley 8300

Tel no (053) 830-8800 / 6 / 7600 Fax no (053) 831 4534

*Training:*

Tel no (053) 830 8843

**Southern Cape***Department of Agriculture, Forestry and Fisheries*

27 Main Str, Demar Building, Knysna

Private Bag X12 Knysna 6570

Tel no (044) 302 6900 Fax no (044) 382-5461

**Western Cape***Department of Water and Sanitation*

3 Blackenberg Rd Bellville

Private Bag X16 Sanlamhof Bellville 7532

Tel no (021) 941 6000 Fax no (021) 950-6100

**WILMAR CONTINENTAL EDIBLE OILS AND FATS (PTY) LTD****INDUSTRY**

Manufacturer edible oils, margarine, mayonnaise, dips, baking fats

**CONTACT INFORMATION**

144 Main Reef Rd Randfontein

PO Box 208 Randfontein 1760

Tel no (011) 278-0300 Fax no (011) 693 1422

**DEPARTMENT OF HEALTH  
EMERGENCY MEDICAL SERVICES****EASTERN CAPE**

Private Bag 27667 Port Elizabeth, 6057

Tel no 041 408 8151 Fax no 041 408 8176

*Distrit Management:*

Tel no (041) 408 8515

*EMS College:*

Tel no (041) 453 0911/5

Dora Nginza Hospital Complex Zwide Port Elizabeth 6000

*Training Department:*

Tel no (041) 408 8524 Fax no (041) 456 1685

**FREE STATE**

P O Box 227 Bloemfontein, 9300

Old Mutuary Building, 21 James Bick Str, Welgehof, Bloemfontein 9300

Tel no (051) 412 0164 Fax no (051) 430 6632

**GAUTENG**

Call Centre: Tel no (011) 564 2210

Switchboard: Tel no (011) 564-2000 / 2001

PO Box 8311 Halfway House 1685

Growth Point Business Park, Continuity SA Building, Unit 4, Cnr Old Pretoria Rd &amp; Tonetti Str, Midrand

*Operations:*

Tel no (011) 564-2053

*Communications:*

Tel no (011) 564 2010 Cell no 072 433 7450

**KWAZULU-NATAL**

Private Bag X9051 Pietermaritzburg 3200

121 Chief Albert Luthuli Str Pietermaritzburg

Tel no (033) 395 2111 / 2589 Fax no (033) 846 7278

*Department head:*

Tel no (033) 395 2589

**LIMPOPO**

Private Bag X9553 Polokwane 0700

58 Schoeman Street 6th Floor 604 Rentmeester Building

Polokwane 0700

Tel no (015) 293 6000

Control Centre tel no (015) 285 6700 / 6755

Switchboard tel no (015) 285 6700 Fax no (015) 295-2990

*EMS College:*

Tel no (015) 285 6755/64 Fax no (015) 295-2990

**MPUMALANGA**

Private Bag X11285 Nelspruit 1200

Building 3 Government Complex Government Boulevard Riverside

White River Rd 1200 Nelspruit

Tel no (013) 766-3412

*EMS College:*

Cell no 082 828 6223

**NORTHERN CAPE**

Private Bag X5049 Kimberley 8300

30 Memorial Rd, Delgravia, Kimberley 8301

Tel no (053) 831 2884 Fax no (053) 831 7645

*EMS College:*

Tel no (053) 831 2884

## **NORTH-WEST**

Geo Science Building, Ngaka Modiri Molema Rd Montshiwa 2735  
Private Bag X 2058 Mmabatho, 2735  
Tel no (018) 473 0324

### *EMS College:*

Tel no (018) 473 0324

# NATIONAL DISASTER MANAGEMENT CENTRE

## **NDMC**

Tel no (012) 848 4601 / 2

*Disaster Risk Reduction Capacity Building and Intervention:*  
Tel no (012) 848 4619

### *Fire Services:*

Tel no (012) 848 4612

## **EASTERN CAPE PROVINCE**

### **DEPARTMENT OF LOCAL GOVERNMENT**

*(Department of Cooperative Governance and Traditional Affairs - Directorate: Disaster Management and Emergency Rescue Services)*

PO Box 12500 Centralhill 6056  
Livingstone Hospital, Port Elizabeth 6000  
Tel no (041) 453 0911

### *Training:*

Tel no (041) 453 0911  
Fax no (041) 456 1685

### *EMS College:*

Tel no (041) 453 0911  
Email: peter.huysaen@echealth.gov.za

### *Sub District Operations:*

Tel no (041) 395 9504

## **FREE STATE PROVINCE**

### **DEPARTMENT OF LOCAL GOVERNMENT AND HOUSING**

*Department of Cooperative Governance and Traditional Affairs*  
Tel no (051) 407 2001  
Direct fax no (051) 407 2019

## **GAUTENG PROVINCE - DEPARTMENT OF COOPERATIVE GOVERNANCE AND TRADITIONAL AFFAIRS**

*Provincial Disaster Management Centre & Provincial Fire & Rescue Services*

11 Janadel Avenue, Riverview Block B, Midrand  
Tel no (010) 345 0801  
Website: www.pdmc.gov.za

## **KWAZULU-NATAL PROVINCE**

### **DEPARTMENT OF LOCAL GOVERNMENT**

*(Department of Cooperative Governance & Traditional Affairs)*

1st floor Mkondeni PDMC office no 82, 66 Shortts Retreat Street,  
Pietermaritzburg, 3200  
Tel no (033) 897 5656 / 9014 / 9006 (033) 846 9003  
Fax no (033) 897 5825

## **LIMPOPO PROVINCE**

### **DEPARTMENT OF LOCAL GOVERNMENT**

*(Department of Co-operative Governance, Human Settlements and Traditional Affairs (Directorate: Disaster Management))*

Switchboard tel no (015) 284 5000  
EMS Department: Tel no (015) 284 5578

## **WESTERN CAPE**

Private Bag X 24 Bellville 7535  
Metro Emergency Medical Services: Mike Pienaar Boulevard  
Tel no (021) 508 4523 Fax no (021) 945 4796

## **MPUMALANGA PROVINCE**

### **DEPARTMENT OF LOCAL GOVERNMENT**

*(Department of Co-operative Governance, Human Settlements and Traditional Affairs - Directorate: Disaster Management)*

Tel no (013) 766 6237  
*Disaster Management Operations:*  
Tel no (013) 757 2081  
Fax no (013) 766 844

## **NORTHERN CAPE PROVINCE**

### **DEPARTMENT OF LOCAL GOVERNMENT**

*(Department of Co-operative Governance, Human Settlements and Traditional Affairs - Sub-Directorate: Disaster Management & Fire Service)*

Tel no (053) 807 9700  
Fax no (053) 831 2904

### *Communication & Information Management:*

Tel no (053) 807 9865 / 9863  
Fax no (053) 831 2904

### *Operations:*

Tel no (053) 807 9700 / 9867  
Fax no (053) 831 2904

### *Development and Planning:*

Tel no (053) 807 2843

## **NORTH WEST PROVINCE**

### **DEPARTMENT OF LOCAL GOVERNMENT**

*(Department of Co-operative Governance, Human Settlements and Traditional Affairs Directorate: Disaster Management)*

Tel no (018) 388 4446

### *Disaster Management Operations:*

Tel no (018) 388 1056  
Fax no (018) 388 1831

## **WESTERN CAPE PROVINCE**

### **DEPARTMENT OF LOCAL GOVERNMENT**

Tel no (021) 937 6301 / 6307

### *Directorate: Disaster Operations*

Fax no (021) 931 9031

### *Preparedness and Response:*

Tel no (021) 937 6317

### *Institutional Capacity:*

Tel no (021) 937 6303

### *Disaster Recovery:*

Tel no (021) 937 6301

### *Disaster Risk Reduction:*

Tel no (021) 937 6359

### *Disaster Mitigation:*

Tel no (021) 937 6330

### *Fire Rescue Services:*

Tel no (021) 937 6334

# DEPARTMENT OF DEFENCE EMERGENCY MANAGEMENT SERVICES

## **DEPARTMENT OF DEFENCE**

### *Rescue Services:*

Tel no (012) 402 2658  
Fax no (012) 402 2653

### *Department of Defence, Chief Directorate Engineering Support Services (DESS):*

Private Bag X319 Pretoria, 0001

### *Department of Defence (Logistic Support Formation):*

Tel no (012) 671-0339

Fax no (012) 671-0247

### *Logistic Support Formation:*

Private Bag x1023 Lyttelton, 0143

## **SA NAVY**

### *Naval Base Simonstown*

Tel: (021) 787-4666  
Private Bag X1 Simon's Town 7995

### *Army Support Base Naboomspruit*

Tel: (014) 743-9606 / 9533 / 9500 / 9502  
Fax: (014) 743-9510

Private Bag X91 Naboomspruit 0560

### *Army Support Base Mpumalanga*

Tel: (013) 756-2084  
Fax: (013) 756-2200

Private Bag X11227 Nelspruit 1200

### *Army Support Base Johannesburg*

Tel: (011) 212-5874/ 5826/5510  
Fax: (011) 212-5777

Private Bag X19 Lenasia 1820

### *Army Support Base Limpopo*

Tel: (015) 299-3349  
Fax: (015) 299 3355  
Private Bag X9304 Polokwane 0700

### *Army Support Base Wallmannsthal*

Switchboard: (012) 529 0999  
Tel: (012) 529-0413  
Fax: (012) 529-0414

### *Wallmannsthal MOSD*

Private Bag X4 Pryramid, 0120

### *Army Support Base Kimberley*

Tel: (053) 830-3028 / 3029 / 3174  
Fax: (053) 830-3019

Private Bag X5056 Diskobolos 8325

### *School of Engineers*

Tel: (056) 216-2005 / 2163 / 2499  
Private Bag X20 Kroonstad 9500

### *Army Support Base Kwa-Zulu Natal*

Tel: (036) 271-3040  
Fax: (036) 271-3140  
Private Bag X9914 Ladysmith 3370

### *Army Support Base Bloemfontein*

Tel: (051) 402-1095/1097  
Fax: (051) 402-1003  
Private Bag X20599 Tempe, Bloemfontein 9315

### *Army Support Base Eastern Cape*

Tel: (041) 505-1531  
Fax: (041) 505-1530  
PO Box 13419 Humewood 6015 Port Elizabeth

### *Army Support Base Oudtshoorn*

Switchboard tel: (044) 203 4111 / 4062  
Fax: (044) 203-4012  
Private Bag X643 Oudtshoorn 6620

### *Army Support Base Western Cape*

Tel: (021) 787-1619/1572  
Fax: (021) 787-1619

Private Bag X1 Kenwyn 7790

### *93 Ammunition Depot*

Switchboard: (053) 631 1869  
Tel: (053) 830 9798

Fax: (053) 456-5044/26

Private Bag X1 Jan Kempdorp, 8550

## **AIR FORCE**

### *Directorate Base Support Systems:*

Tel: (012) 312-2531  
Fax: (012) 312-1182 / 2707

### *Force Preparation Fire and Rescue:*

Tel: (012) 312-2969  
Fax: (012) 312-1182

### *Project Management:*

Tel: (012) 312-1053  
Fax: (012) 312-1182

### *Directorate Education Training and Development:*

Tel: (012) 312-2811

### *Military Aviation Rescue and Fire Fighting School (MARFFS):*

Tel: (012) 672-5022

### *Air Force Base Langebaanweg:*

Tel: (022) 706-2317/2256/2206/2173  
Fax: (022) 706-2168

Air Force Base Langebaanweg, Langebaan

### *Air Force Base Makhado:*

Emergency: (015) 577-2104  
Tel: (015) 577-2104/3

Fax: (015) 577-2711

Private Bag X2010 Makhado 0920

### *Air Force Base Durban:*

Fire Chief: Warrant Officer 2 K Pillay  
Tel: (031) 450-4943/4977

Fax: (031) 450-4730

PO Box 1120 Amanzimtoti 4125

### *Air Force Base Ysterplaat:*

Fire Chief: Warrant Officer 1 J. Wilson  
Tel: (021) 508-6382/6266

Fax: (021) 508-6531

Private Bag X4 Ysterplaat Air Force Base, Cape Town 7425

### *Air Force Base Overberg:*

Tel: (028) 425-4088/9  
Fax: (028) 425-4087

Private Bag X14 Bredasdorp 7280

### *Air Force Base Waterkloof/Swartkops:*

Air command unit  
Tel: (012) 672-4022 / 3925 / 3442

Fax: (012) 672-4162

Private Bag X1001 Lyttelton 0140

### *Air Force Base Hoedspruit:*

Tel: (015) 799-2174/2197  
Fax: (015) 799-2491

Private Bag X504 Hoedspruit 1380

### *Air Force Base Bloemspuit:*

Tel: (051) 405-6121/22  
Fax: (051) 405-6049

PO Box 20608 AFB Bloemspuit, Bloemfontein 9300



# ASSOCIATIONS / INSTITUTES

## CAPE PENINSULA FIRE PROTECTION

Tel no: (021) 689 7438/9  
Fax no: (021) 685 5944

### East Region

Tel no: (021) 847 2254  
Fax no: (021) 847 2226

### North Region

Fax: 021 979 0093  
Email: northmanager@cpfpa.org.za

## DISASTER MANAGEMENT INSTITUTE OF SOUTHERN AFRICA

123 Rieffontein Road Primrose Germiston,  
PO Box 7130 Primrose Hill, 1417  
Tel no: (011) 822-1634  
Fax no: 086 652 8066  
E-mail: disaster@disaster.co.za

## EMERGENCY SERVICES CHAPLAINCY SOUTHERN AFRICA

PO Box 17526 Norkem Park, 1631  
Email: Info@escsa.org.za  
Fax no 0865772767  
www.escsa.org.za

## FIRE PROFESSIONS COUNCIL OF SOUTHERN AFRICA

Cell: 076 480 3731 / 081 464 9957  
Whatsup: 074 021 7787  
Email: info@fpcs.co.za

## FIRE PROTECTION ASSOCIATION OF SOUTHERN AFRICA

PO Box 15467 Impala Park 1472  
105 Springbok Road Bartlett Boksburg  
Tel no: (011) ) 397-1618/9

## INSTITUTION OF FIRE ENGINEERS (SA)

No 16, 11th Ave, Cnr 5th Street, Houghton Estate, Johannesburg  
PO Box 1033 Houghton 2041  
Tel no (011) 788-4329  
Fax no: (011) 880 6286  
Website: www.ife.org.za

## K9 SEARCH AND RESCUE ASSOCIATION

Gauteng Emergencies:  
Tel no: 078 137 1073  
Website: www.k9sara.co.za

### Training:

Cell no 082 724 2557

Western Cape Emergencies:  
Tel no (021) 937 0300

## KZN FIRE PROTECTION ASSOCIATION

Umbrella Fire Protection Association of KZN  
Conservation of Farmland in KZN  
Tel no (033) 330-8421

## LPGSASA: LIQUEFIED PETROLEUM GAS SAFETY ASSOCIATION OF SOUTHERN AFRICA

Tel no (011) 886-9702  
www.lpgas.co.za

## MOUNTAIN CLUB OF SOUTH AFRICA

Mobile: 083 702 6241  
Email: secretary@mcsa.org.za

## NATIONAL DISASTER MANAGEMENT CENTRE

Department of Provincial and Local Government  
Private Bag X804 Pretoria 0001

## Legislation, Policy and Compliance Management:

Tel no (012) 848 4610  
Fax no 086 773 4537

## SARZA

Off-road rescue unit  
Emergency Tel no: 010 140 1911  
Email: contact@sarza.co.za  
Operations: Email: ops.gtn@sarza.co.za  
Website: https://www.sarza.co.za

## SAFETY FIRST ASSOCIATION

Tel no: +27 (0) 65 979-7879  
E-mail: admin@safety1st.co.za  
www.safety1st.co.za

## SAQCC GAS

Tel no: (011) 285 0038  
Fax no: 086 550 8444  
Email: info@saqccgas.co.za

## SOUTH AFRICAN BUREAU OF STANDARDS (SABS)

Tel no: 0861 277 227 /012 428 7911  
Fax no: 012 344 1568  
Email: info@sabs.co.za  
Website: www.sabs.co.za

## SOUTHERN AFRICAN EMERGENCY SERVICES INSTITUTE

PO Box 613 Krugersdorp 1740  
Tel no: (011) 660-5672 / 7555  
Fax no: (011) 660-1887 / 086 544 0008  
Email: info@saesi.com

## SOUTH AFRICAN PRIVATE AMBULANCE AND EMERGENCY SERVICES ASSOCIATION (AMBUSAVE)

PO Box 4051 Brakpan 1453  
Tel no: (011) 915-4909  
Fax no: (011) 915-4905

## SOUTHERN CAPE FIRE PROTECTION ASSOCIATION

Private Bag x 12 Knysna 6570  
Tel no: (044) 302 6912  
Fax no: 086 616 1682  
Email: adminfpa@telkomsa.net

### Fire Advisor:

Tel no: (044) 302 6920  
Fax no: (044) 382 5461

### Riversdale Office:

Western Region Area Tel no: (028) 713 1987

### Knysna Office:

3rd floor Demar Centre Main Road, Knysna  
Tel no: (044) 302 6912 / 6908  
Email: managerfpa@gmail.com  
Fax no: 086 616 1682

## WESTERN CAPE FIREFIGHTERS ASSOCIATION

1st Floor, 71 Klipfontein Road Rondebosch 7700  
Tel no 021 6869303  
Fax no 021 6861547  
Email: wcfirefighters@mweb.co.za

## WORKING ON FIRE

(Wildland firefighting company - Implementer of the Working on Fire Programme DFEE EPWP)  
Operations Centre: Nelspruit Airport  
01 Club Street, Old Nelspruit Airport, Nelspruit  
PO Box 4555 Nelspruit 1200  
Head Office Tel no: 087 352 4880  
Email: comms@wofire.co.za

Suppliers of  
embroidered:  
Caps / Jackets / T-shirts  
And any other  
embroidery  
requirements



EM  
ROIDERY

GRANITE DESIGNS

Cell: 066 312 6505

Email: junestjohn06@yahoo.com

# When lives are on the line you can't afford to take risks



## JusCheck

An screen device which is simple to use. For the detection of drug abuse in saliva. Test accurately for 6 drugs in 5 minutes.

**NEW!**



## AlcoBlow® Rapid Test

Strongest and fastest breath alcohol tester on the market. AlcoBlow® Rapid Test requires the smallest breath sample and ensures accurate results first time, every time. Results are obtained within seconds. Very economical operation, no disposable mouthpieces are required.



## LionAlcometer® 600

The Lion Alcometer 600 and it's printer have a touch screen display. Allows for entering of the test subject name, surname and ID number. Perfect for CCMA cases.



## ALCONTROL

Made to be rugged and simple to use, the ALCONTROL can be used in any environment for operator free breathalyser testing. Ideal for controlling entrance at turnstile gates.



## URINE TESTING

Test accurately for up to 10 drug types. Test results are available within 5 minutes.



**Emergency services**  
alcohol and drug testing **specialists**

High speed testers capable of testing high volumes of people at site entrance/exit points and portable instruments with digital readouts for use at remote sites providing immediate printed evidence.

Ensuring safer working environments for over 40 years  
Help is one call away +27 12 343 8114 or visit [www.alcosafe.co.za](http://www.alcosafe.co.za) for more information

# Lightweight Polypropylene Body Vehicle Manufacturer

Steel has become synonymous with power, robustness and reliability. Steel is the first choice in many applications, but polypropylene is seen as a superior option. There are numerous factors behind the rising popularity of polypropylene Emergency vehicles. Let us learn more about the advantages offered by the polypropylene body:

- The factor of cost;
- Fabrication of steel is a time-consuming process, whereas plastic can be easily converted into custom style and designs.
- Corrosion resistance;
- Polypropylene delivers superior performance over steel.
- Water is an enemy of steel, but polypropylene and other plastics are chemically inert.
- More and more vehicle owners are switching to corrosion-resistant vehicles.
- Lightweight body;
- Polypropylene is 40% lighter than steel, which makes it an ideal choice for constructing the body of the vehicle.
- Aquila Corp (Pty) Ltd fully understands the concerns and requirements of the modern customers.
- Chemical resistance;
- Polypropylene successfully withstands the effects of alkalis and acids.
- Durability and strength;
- Strength offered by polypropylene is comparable to that of steel.
- Polypropylene has high tensile strength.
- It is resistant and non-toxic. Polypropylene retains and stiffness, which makes it durable.
- Advanced fire fighting vehicles require additional strength, greater mobility, and higher flexibility.
- The lightweight polypropylene emergency vehicles are superior and more flexible in comparison to conventional vehicles.
- If you are looking for a reliable polypropylene body manufacturer, Aquila Corp (Pty) Ltd is the best option.
- We also design, develop and deliver tailored solutions to the customers.



## AQUILACORP

Unit 18, Aquaplan Business Park  
120 E.P. Malan Street  
Pomona Kempton Park  
South Africa

[aquilacorpsa.co.za](http://aquilacorpsa.co.za)  
[trtg.co.za](http://trtg.co.za)

## AQUILACORP



### Rapid Intervention Vehicles

## AQUILACORP



### Ambulance Conversions

## AQUILACORP



### Super Structures